



Computational Thinking and Artificial Intelligence

Class 8

Teacher Handbook



First Edition: March, 2026

Country of Publication: India

Published by: Central Board of Secondary Education, Integrated Office, Sector 23, Dwarka, New Delhi-110077

PREFACE

The National Education Policy (NEP) aims to position India as a leader in emerging knowledge fields by integrating technologies like AI, Machine Learning, Big Data and Computational Thinking into school education. It promotes technology-enabled, interactive and gamified learning using tools such as Augmented Reality (AR), Virtual Reality (VR), and virtual labs to foster creativity, problem-solving, and interdisciplinary exploration. NCFSE 23 carries this recommendation further for implementation.

While Artificial Intelligence (AI) is an important requirement, Computational Thinking (CT) should be a broader skill, developing a foundation for learning AI. It can cover various aspects like Cybersecurity, basic networking, etc. Hence, CBSE approaches this by integrating Computational Thinking with AI and other technological advancements, without dependence on any platform.

Learners engage with problems involving powers and number systems, proportional reasoning, geometric configurations and structured distributions, requiring decomposition of multi-variable scenarios, identification of complex patterns and design of stepwise algorithms under constraints. The Artificial Intelligence component deepens understanding of the AI project lifecycle, data-driven decision-making and ethical considerations such as bias and fairness, enabling students to critically analyse how data and models influence outcomes. The document also provides pedagogical guidance, resources, and assessment support aligned with NEP 2020 for effective classroom implementation.

TEAM CBSE

ACKNOWLEDGEMENTS

Expert Committee

1. Dr. Karthik Raman, Core Leadership, IIT Madras Bodhan AI Foundation; Professor, Department of Data Science and AI, Wadhvani School of Data Science and AI, IIT Madras
2. Dr. Rajesh Kumar, Professor, Department of Electrical Engineering, MNIT, Jaipur
3. Dr. Seema Verma, Professor (ECE), Project Director (Siemens CoE), NITTTTR, Bhopal
4. Dr. S. Neethi, Core Leadership, IIT Madras Bodhan AI Foundation; Professor of Practice, Department of Data Science and AI, Wadhvani School of Data Science and AI, IIT Madras
5. Dr. Arun L. Naik, Associate Professor, Mathematics Education, Azim Premji University, Bengaluru
6. Dr. Aanchal Chomal, Associate Professor, School of Continuing Education and University Resource Centre, Azim Premji University
7. Dr. Ankit Vijayvargiya, Assistant Professor, School of Technology, Dhirubhai Ambani University, Gandhinagar
8. Sh. R P Singh, Associate Prof & Additional Director, CBSE
9. Mr. Mikin Lala, (IIT Roorkee and IIM Calcutta Alumnus), Field Expert
10. Ms. Rekha Malhotra, (Alumna of the British Institute (Business Management and Advertising), Frameworks Mumbai (Advanced Certification in Computer Science), and Workstation (3D Animation)), Field Expert

Material Production Group

1. Dr. S. Neethi, Core Leadership, IIT Madras Bodhan AI Foundation; Professor of Practice, Department of Data Science and AI, Wadhvani School of Data Science and AI, IIT Madras
2. Dr. Ankit Vijayvargiya, Assistant Professor, School of Technology, Dhirubhai Ambani University, Gandhinagar.
3. Mr. Jay Thakkar, Senior Technical Officer, Centre for Creative Learning, IIT Gandhinagar
4. Mr. Chris John, Project Scientist, Centre for Creative Learning, IIT Gandhinagar
5. Ms Rekha Malhotra {Alumna of the British Institute (Business Management and Advertising), Frameworks Mumbai (Advanced Certification in Computer Science), and Workstation (3D Animation)}, Field Expert
6. Mr. Mikin Lala, (IIT Roorkee and IIM Calcutta Alumnus), Field Expert
7. Ms. Amatullah Mustafa Neemuchwala, Field Expert
8. Ms. Telidevara Sree Lasya, Field Expert
9. Mr. Parth Oza, Field Expert
10. Mr. Deep Mayekar, Field Expert
11. Mr. Mayank Patil, Field Expert
12. Ms. Shivraj Ugale, Field Expert
13. Mr. Raj Dhorade, Field Expert
14. Mr. Nilesh Vijay Rajput, Field Expert

The efforts of Prof. Manish Jain and his whole team from Centre for Creative Learning, IIT Gandhinagar are also acknowledged and deeply appreciated.

TABLE OF CONTENTS

PART-1 COMPUTATIONAL THINKING

SR. NO.	CHAPTER	PAGE NO.
1.	Introduction	5
2.	How to Use this Book?	9
3.	A Square and a Cube	11
4.	Power Play	21
5.	A Story of Numbers	29
6.	Quadrilaterals	45
7.	Number Play	52
8.	We Distribute Yet Things Multiply	59
9.	Proportional Reasoning	69

PART-2 ARTIFICIAL INTELLIGENCE

SR. NO.	CHAPTER TITLE	ETHICAL AWARENESS	PAGE NO
1	AI Project Lifecycle	Responsible problem solving	80
2	Artificial Intelligence and Its Applications	Understanding impact of AI systems	83
3	Data and Fairness in AI	Promoting fairness and inclusivity	85
4	Ethics and Responsible AI	Ethical decision-making in technology	91

Introduction

Computational Thinking (CT) is a problem-solving approach that comprises Decomposition, Pattern Recognition, Abstraction, Algorithm Design, Data Analysis and Troubleshooting. Computational Thinking Skills involve solving complex problems that promote thinking skills such as critical & creative thinking, abstraction and pattern recognition, as well as algorithmic thinking. Problem identification and problem solving necessitate the application of multidisciplinary understanding for creating effective solutions.

Artificial intelligence (AI) is a cutting-edge technology that empowers machines and computers to perform tasks that usually require mimicking human intelligence. These machines can perform complex thinking processes such as data analysis, pattern recognition, prediction of trends, solving problems and decision making. Thus, AI involves simulating cognitive processes associated with human intelligence and is widely applicable in various sectors such as banking, healthcare, defence, education, entertainment, agriculture and others, for processing information, solving intricate problems and for planning.

The National Education Policy (NEP) aims for India to emerge as a global leader in new emerging knowledge domains such as artificial intelligence, machine learning, data analytics, 3-D machining etc. To realise this goal, the policy suggests teaching students' mathematics and computational thinking, along with new subjects like artificial intelligence, machine learning, and data science during their school education. The policy also focuses on technology-enabled learning and classrooms by using tools like artificial intelligence, machine learning and adaptive testing to create knowledge.

The National Curriculum for School Education draws from this policy aspiration and emphasises the need to introduce these emerging domains of study and technologies in the school curriculum. It recommends inclusion of subjects such as design thinking, augmented reality, virtual reality, artificial intelligence, and computational thinking. Additionally, it promotes the use of gamified content, interactive content, and immersive experiences (such as AR, VR or virtual labs) to enhance student learning. In a variety of subjects, including design, music, art and sciences, these resources support students in knowledge creation and exploration, and development of capacities such as problem-solving, critical and creative thinking.

CBSE, under the aegis of the Department of School Education and Literacy, Ministry of Education, Govt. of India, is implementing a Curriculum on Computational Thinking and Artificial Intelligence (CT & AI) to inculcate AI-readiness in school students. This curriculum will be implemented from classes 3rd to 8th, in the session 2026-27, and aims to develop AI-Ready learners, by focusing on Computational Thinking Skills. The AI-readiness, so inculcated through CT Skills, will help develop the capacities of learners to use computational thinking, such as logical thinking, problem solving, pattern recognition, and so on, and understand the role and use of Artificial Intelligence in daily life. The Curriculum aims to build strong foundations in computational thinking, digital literacy and responsible use of technology, along with nurturing innovation, critical thinking, and ethical decision-making capacities.

1. **Relevance: Importance of introducing Computational Thinking (CT) and Artificial Intelligence (AI)**

- **Preparing for the future:** To contribute to the world of work in modern societies, individuals need capabilities such as problem solving, using data effectively, identifying patterns and applying AI ethically for various purposes in life.
- **Holistic Development:** Study of CT and AI contributes to development of reasoning, logical thinking, creative problem-solving skills, critical thinking, and ethical decision-making abilities, leading to individual flourishing and the creation of responsible digital citizens.
- **Interdisciplinary Relevance:** Embedding CT and AI concepts helps students develop an integrated view of the world by connecting various disciplines such as Mathematics, Science, and Humanities, showing that knowledge is not compartmentalized.
- **Innovation and Entrepreneurship:** At its core, CT and AI are about solving problems and devising innovative solutions, which leads to an entrepreneurial and innovative mindset.
- **Ethical Awareness:** Study of CT & AI will sensitize learners about the misuse and bias, fairness, and inclusivity in AI systems.

2. **Objectives: (Curricular Goals)**

- **CG-1:** Develops skills and capacities of computational thinking, namely- decomposition, pattern recognition, data representation, generalisation, abstraction, and algorithms to solve problems where such techniques of computational thinking are effective.
- **CG-2:** Develop spatial and visual reasoning.
- **CG-3:** Gain foundational knowledge of AI, its types, and domains.
- **CG-4:** Understand key ethical terms such as bias and fairness in relation to AI.
- **CG-5:** Demonstrates proficiency to use Computer & other devices, computer applications for learning and practical purposes such as data analysis, preparation of visual representations and communication of ideas.

3. **Learning Outcomes:**

Computational Thinking (CT) Learning Outcomes

ABSTRACT THINKING

Students will be able to solve advanced, multi-layered problems involving abstract relationships and hidden structures, using:

- properties and relationships of numbers (powers, factors, remainders, divisibility)
- generalization across different number systems (decimal, binary, ternary, Roman, Chinese numerals)
- spatial visualization of 2D and 3D figures, including overlaps, intersections, and transformations
- logical interpretation of symbols, codes and operations representing numerical or algebraic ideas
- identification of essential information by ignoring irrelevant or misleading data

PATTERN RECOGNITION

Students will be able to identify, compare and extend complex patterns involving multiple simultaneous changes, formed using:

- Powers, exponents and numerical structures
- Relationships across different representations of the same number
- Geometric configurations and shape-based sequences
- Conditional patterns based on rules, constraints or dependencies
- Mixed patterns involving numbers, symbols, shapes, and movement

DECOMPOSITION

Students will be able to break down high-order logical problems into manageable components by:

- Separating given conditions, constraints, and goals
- Analyzing multi-step processes such as distribution, transfers and exchanges
- Breaking numerical expressions into simpler equivalent forms
- Interpreting tables, grids, networks and diagrams with multiple dependencies
- Structuring problems involving multiple variables, positions or cases

ALGORITHMIC THINKING

Students will be able to design, follow and evaluate multi-step logical procedures to solve problems involving:

- Rule-based transformations of numbers or symbols
- Stepwise movement on grids, tracks or paths with constraints
- Conditional instructions (if–then, either–or, must/must not)
- Sequential decision-making under given limitations
- Optimisation problems involving maximum or minimum outcomes

Artificial Intelligence (AI) Learning Outcomes

By the end of Grade 8, learners will be able to:

- Describe the stages of the AI project cycle as a stepwise structure (Define Problem, Collect Data, Test AI Tools, Reflect and Improve)
- Apply no-code tools to tackle real-world problems and reflect on their utility/effectiveness
- Explain how AI uses data, find and research sources of bias in datasets, and apply basic strategies to ensure fairness and inclusivity
- Recognize how bias in AI leads to unfair conclusions and realize the importance of accountability, privacy, and serving human interests
- Explain the uses of AI in daily life and understand AI as a specific type of algorithm that uses datasets, learning and prediction
- Analyse contributions of AI to fields like healthcare, automation, and education, understanding both benefits and risks
- Describe AI ethics as the values and guidelines that ensure AI is created and used responsibly

4. Mapped with NEP and NCF 2023:

- The National Education Policy (NEP) 2020 aims to position India as a leader in emerging fields by integrating AI, Machine Learning and CT into school education

- The National Curriculum Framework for School Education (NCF-SE), 2023 serves as the foundation for implementation, drawing Curricular Goals from the Aims of Education.
- Learning standards are designed as foundational capacities that are progressive, age-appropriate, and aligned to NCF-SE 2023.

5. Time Allocation:

The Middle Stage suggests 100 hours annually, allocated as follows for Grade 8:

- **Advanced CT Skills:** 40 hours per academic year
- **Introductory Concepts of AI:** 20 hours per academic year
- **Interdisciplinary Projects:** 40 hours total (20 hours for each of the two required projects)

6. Approach / Pedagogy:

- **Activity-Based:** Use of complex puzzles, riddles, and games to build on previous CT abilities
- **Experiential Learning:** Delivering fundamental AI concepts through explanations, demonstrations, and hands-on experience
- **Collaborative Work:** Organising group discussions, debates and collaborative projects that integrate CT & AI
- **Inquiry-Based:** Independent student activities such as data collection, organisation, analysis, and creation of diagrams/flow charts using digital tools or manually
- **Ethical Reflection:** Case studies and debates on the social impact and ethical use of AI.

7. Assessment:

Assessment is continuous, formative and competency-based, focusing on the ability to apply knowledge rather than rote memorization. Methods include:

- Written Tests and Practical Examinations
- Interactive Group Activities
- Thematic Projects and Reflective Journals
- Teacher Observation Journals and Group Discussions

8. CT and AI Transition:

Computational Thinking forms the intellectual backbone and foundation for learning AI. The curriculum follows a phased approach where CT skills—like breaking problems into parts and spotting patterns—build the cognitive structures necessary for students to eventually understand and create AI-driven solutions.

How to Use This Book?

PART-1 Computational Thinking

Part 1 of this handbook is designed as a companion to the Mathematics textbook and is intended to be used alongside regular classroom teaching. Since it follows the same chapter sequence, the Mathematics teacher can seamlessly integrate it into daily instruction. As concepts are introduced in class, the corresponding questions from this book can be used to deepen understanding and encourage application.

Before beginning a chapter, the teacher is encouraged to read and identify the underlying concepts required for each question and plan how to align them with classroom teaching. As these concepts are taught, the teacher can introduce the related 'thinking questions' to students. It is important to note that the questions in this book are thinking-based and designed to promote analysis, reasoning, and problem-solving.

Teachers should adopt a facilitative approach, guiding students through prompts and discussions rather than directly providing solutions. Students should be given time to think and attempt independently, followed by classroom discussions where different approaches are shared and explored.

Some chapters also include activities that build intuition and engagement. These should be conducted before attempting the questions, as they help students approach the problems with better understanding.

PART-2 Artificial Intelligence

Part 2 of the handbook provides a structured introduction to Artificial Intelligence (AI) as a technology that enables machines to learn from data, recognise patterns, and make decisions. The concepts of AI are presented using simple explanations and real-life examples from areas such as healthcare, education, transport, and communication.

Each chapter includes:

- ▶ Foundational understanding of AI concepts
- ▶ Real-life examples and applications of AI
- ▶ Introduction to key AI domains such as Data Science, Computer Vision, and Natural Language Processing
- ▶ Activities and data-based tasks
- ▶ Reflection on ethical use of AI

The AI content progresses from introduction to application, including introductory predictive techniques such as regression, classification, and clustering. The book emphasises ethical and responsible use of AI, including introduction to bias, fairness, privacy, and safe use of technology, enabling informed and thoughtful engagement with AI systems.

Teachers should approach the book with the mindset that the process of thinking is more important than arriving at the correct answer. Creating a safe and encouraging environment where students feel comfortable making mistakes, exploring multiple strategies, and expressing their reasoning is essential. The goal is to nurture confident, independent thinkers rather than focus solely on correctness.

PART-1

COMPUTATIONAL THINKING

Chapter 1: A Square and a Cube

1. In the following grid, all the circles follow the same theme. What will be the value of $A + B$?

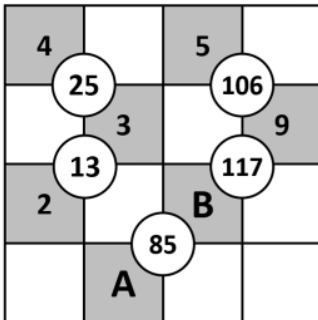

- a) 12 b) 14 c) 13 d) 15

Answer: c

Solution:

In the given grid, the number in each circle is the sum of the squares of the digits from the grey cells connected to it. For example:

$$4^2 + 3^2 = 16 + 9 = \mathbf{25}$$

$$2^2 + 3^2 = 4 + 9 = \mathbf{13}$$

$$5^2 + 9^2 = 25 + 81 = \mathbf{106}$$

Similarly,

$$9^2 + B^2 = 117$$

$$81 + B^2 = 117$$

$$B^2 = 117 - 81$$

$$B^2 = 36$$

$$B = 6$$

Also,

$$B^2 + A^2 = 85$$

$$6^2 + A^2 = 85$$

$$A^2 = 85 - 36$$

$$A^2 = 49$$

$$A = 7$$

$$A = 7 \text{ and } B = 6. \text{ So, } A + B = 13$$

Hence, option c is correct.

2. Sam writes a list of natural numbers. The list has three perfect cubes and three perfect squares. If no number in the list has more than two digits, what is the **MINIMUM** number of distinct numbers he must have written?

- a) 3 b) 4 c) 5 d) 6

Answer: b

Solution:

Sam writes a list of natural numbers of three perfect cubes and three perfect squares, where no number has more than two digits.

To minimize the number of distinct elements in the list, Sam should use numbers that are both perfect squares and perfect cubes.

Let us see the perfect cubes and perfect squares:

Perfect squares = 1, 4, 9, 16, 25, 36, 49, 64, 81

Perfect cubes = 1, 8, 27, 64

Since 1 and 64 are both perfect squares and perfect cubes, Sam needs 2 more numbers in the list. Therefore, a minimum of 4 numbers can be written.

Hence, option b is the correct answer.

3. If AB is a two-digit number whose cube is in the form of a 4-digit number “___ __ C” such that $A < C < B$, how many different values can C have?

a) 2

b) 3

c) 4

d) More than 4

Answer: a

Solution:

We know that $10 \times 10 \times 10 = 1000$ is the smallest 4-digit cube number. So, AB can be 10 or more than 10.

Similarly, $21 \times 21 \times 21 = 9261$, is the largest 4-digit cube number. So, AB can be any number from 10 to 21.

Also, given that $A < C < B$

The units digit of the number is greater than the units digit of its cube.

Regardless of how many digits a number has, the units digit of its cube always depends on the units digit of the original number. Let's look at the units digits of a number and its cube number:

Example	Digit in the units place of the original number	Digit in the units place of its cube
$10 \times 10 \times 10 = 1000$	0	0
$11 \times 11 \times 11 = 1331$	1	1
$12 \times 12 \times 12 = 1728$	2	8
$13 \times 13 \times 13 = 2197$	3	7
$14 \times 14 \times 14 = 2744$	4	4
$15 \times 15 \times 15 = 3375$	5	5
$16 \times 16 \times 16 = 4096$	6	6
$17 \times 17 \times 17 = 4913$	7	3
$18 \times 18 \times 18 = 5832$	8	2
$19 \times 19 \times 19 = 6859$	9	9

Hence, from the table, we can say that only 7 and 8 are possible units place digits of the number, where the units place digit of the cube is smaller.

When $B = 7$ or 8 , C can be 2 or 3.

Hence, C can take only two values, either 2 or 3.

Hence, option a is correct.

4. $56 \times k$ is a perfect cube where k is a natural number. What could be the smallest possible value of k ?

- a) 36 b) 49 c) 56 d) 72

Answer: b

Solution:

We are given that $56 \times k$ is a perfect cube.

This means that the prime factors of $56 \times k$ appear thrice or a number of times which is a multiple of 3.

We are asked to find the minimum possible value of k .

So, the smallest possible prime factors that are required to make the product of ' $56 \times k$ ' a perfect cube will be the value of k .

Now, prime factorization of $56 = 2 \times 2 \times 2 \times 7$

Here, 2 appears thrice but we only have one 7 which means k needs to be 7×7 so that the product $56 \times k = 2 \times 2 \times 2 \times 7 \times 7 \times 7$ becomes a perfect cube.

Hence, the smallest possible value of k is $7 \times 7 = 49$.

Therefore, option b is correct.

5. Each geometrical shape denotes a certain operation. What will come in place of “?”

$$\boxed{16} \longrightarrow 256 \qquad \boxed{19} \longrightarrow 361$$

$$\boxed{15} \longrightarrow 3375 \qquad \boxed{11} \longrightarrow 1331$$

$$\boxed{14} + \boxed{12} \longrightarrow ?$$

- a) 2888 b) 1914 c) 1924 d) 340

Answer: c

Solution:

The perfect square of the number written inside a square is given on the right side of the arrow.

For example: $16^2 = 256$ and $19^2 = 361$

Similarly, the cube number of the number written inside a cube is given on the right side of the arrow.

$15^3 = 3375$ and $11^3 = 1331$

So, let's first replace each figure with its correct value.

14 is present in a square and 12 is present in a cube.

So, the expression becomes:

$$\begin{aligned} &14^2 + 12^3 \\ &= 196 + 1728 \\ &= 1924 \end{aligned}$$

Hence, the correct answer is option c.

6. XYZ is a 3-digit number such that it is the square of a multiple of 5.

What will be the HIGHEST possible remainder of $(XYZ)/100$?

- a) 10 b) 15 c) 20 d) 25

Answer: d

Solution:

The multiples of 5 are 5, 10, 15, 20, 25, 30, 35, 40, ... and so on.

Among these, we cannot consider 5 and numbers above 30 (like 35, 40, .. and so on), as their squares are not 3-digit numbers.

The multiples of 5 either end with 0 or 5.

Squares of multiples ending with 0, will end with '00' ($10^2 = 100$, $20^2 = 400$)

Hence, dividing them by 100 results in zero as the remainder.

Squares of 15 and 25 will be: $15^2 = 225$ and $25^2 = 625$. So, the squares of numbers ending with 5 will end with 25.

Dividing them by 100 will result in a remainder of 25. (Example: $625/100$ gives 6 as quotient and 25 as remainder)

In both cases, the remainder is either 0 or 25.

Since we want the highest possible remainder, the correct answer is 25, which is option d.

7. A class teacher wrote the following pattern on the board, where an expression is written after the “=” sign in each row. She then asked the class to find the expression for $13^3 - 12^3$. Which DIGIT appears the HIGHEST number of times in the expression that denotes $13^3 - 12^3$?

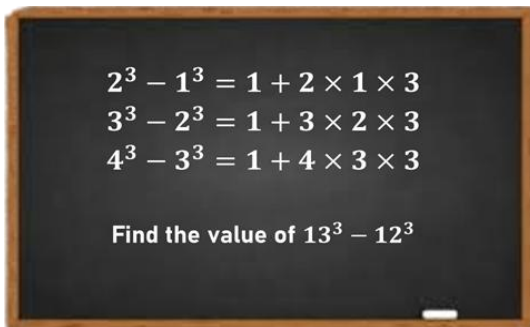

- a) 1 b) 2 c) 3 d) 4

Answer: a

Solution:

Let's solve this logically.

We can see that there exists a pattern in the expressions, in each row.

In each row, we can find the pattern $n^3 - (n - 1)^3 = 1 + n \times (n - 1) \times 3$, where $n = 1, 2, 3$, and so on. (for example: $5^3 - 4^3$ will be $1 + 5 \times 4 \times 3$)

Hence, $13^3 - 12^3 = 1 + 13 \times 12 \times 3$

So, in the resultant expression, there are three 1s, one 2, and two 3s.

1 occurs the highest number of times.

Therefore, option a is correct.

8. Fill in the grid with the squares and cubes of digits 2 to 5 such that:

- Each square/cube number appears twice
- Both square and cube of the same number cannot appear in the same row/column
- Same numbers do not appear diagonally

What is the maximum possible sum that can be obtained by the cells present in the configuration of Shape A (without rotation)?

64			4
27	125		
8		9	25
		16	

GRID

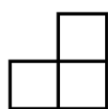

Shape A

- a) 197 b) 161 c) 193 d) 216

Answer: a

Solution:

We need to fill the grid such that no number repeats diagonally; both square and cube of the same number do not appear in the same row/column; and each number appears twice.

Solving for squares and cubes of 2:

- We need to place 4 and 8 once more.
- The existing 4 and 8 already occupy some rows and columns, so those rows and columns cannot be used again.
- After eliminating those, only Row 2 and Row 4 are left where both numbers can go.
- Similarly, only Column 2 and Column 3 are left where both numbers can be placed.

Hence, we place 4 and 8 in Row 2 or Row 4 and Column 2 or Column 3:

64			4
27	125		
8		9	25
		16	

4 cannot come beside 125, as it will be diagonal to 4. Hence, 8 will be next to 125 and 4 will be next to 16 as shown below:

64			4
27	125	8	
8		9	25
	4	16	

Solving for squares and cubes of 3:

We need to place 9 and 27 once more.

- The existing 9 and 27 already block some rows and columns.
- After removing those, only Row 1 and Row 4 remain possible.
- Also, only Column 2 and Column 4 remain available.

Hence, we place 9 and 27 in Row 1 or Row 4 and Column 2 or Column 4.

64			4
27	125	8	
8		9	25
	4	16	

27 cannot come above 125 as it will be diagonal to 27 and 9 cannot come next to 16 as it will be diagonal to 9. Hence, 9 will be above 125 and 27 will be next to 16, as shown below:

64	9		4
27	125	8	
8		9	25
	4	16	27

Solving for squares and cubes of 4:

We need to place 16 and 64 once more.

- The existing 16 and 64 block certain rows and columns.
- The remaining possible rows are Row 2 and Row 3.
- The remaining possible columns are Column 2 and Column 4.

Hence, we place 16 and 64 in Row 2 or Row 3 and Column 2 or Column 4.

64	9		4
27	125	8	
8		9	25
	4	16	27

16 cannot come below 125 as it will be diagonal to 16. Hence, 64 will be below 125 and 16 will be below 4, as shown below:

64	9		4
27	125	8	16
8	64	9	25
	4	16	27

Solving for squares and cubes of 5:

The square and cube of 5 are 25 and 125. We need to place 25 and 125 in the remaining cells. 125 cannot be placed in row 1 as it would be diagonal to 125. Hence, 125 should be in row 4 and 25 should be in row 1 as shown below:

64	9	25	4
27	125	8	16
8	64	9	25
125	4	16	27

Consider Shape A such that we get the maximum sum from the numbers in it.

To get the maximum sum, we need to have the largest number in the grid to be present in Shape A. Thus, 125 should be present in Shape A. 64 (the next largest) is also around 125, so we can also have 64, as shown below:

64	9	25	4
27	125	8	16
8	64	9	25
125	4	16	27

64	9	25	4
27	125	8	16
8	64	9	25
125	4	16	27

Among both the Shape A configurations, the one with 8 in it will give a larger sum.

Thus, the maximum possible sum of numbers of shape A is: $8 + 64 + 125 = 197$.

Hence, option a is the correct answer.

9. The image below shows a logic machine, where numbers move from Column to Column (starting from column 1 as input and reach column 4) through the tunnel, where they change in a different way, each time. What would be the sum of A, B, and C?

Column 1	Column 2	Column 3	Column 4
4	15	6	216
22	483	15	3375
11	120	3	27
7	A	B	C

a) 2259

b) 1795

c) 180

d) 1788

Answer: d

Solution:

The following things are happening here:

In the first tunnel, the number in column 1 is squared, and 1 is deducted from it. For example:

$$4^2 = 16$$

$$16 - 1 = 15.$$

Similarly, $22^2 = 484$

$$484 - 1 = 483$$

Hence for 7: $7^2 = 49$

$$49 - 1 = 48.$$

A = 48

Column 1	Column 2	Column 3	Column 4
4	15	6	216
22	483	15	3375
11	120	3	27
7	48	B	C

In the second tunnel, the digits of column two are added. For example:

$$15: 1 + 5 = 6.$$

$$483: 4 + 8 + 3 = 15.$$

Hence for 48, $48: 4 + 8 = 12.$

B = 12

Column 1	Column 2	Column 3	Column 4
4	15	6	216
22	483	15	3375
11	120	3	27
7	48	12	C

Finally, the number in the fourth column is the cube of the number in the third column. For example:

$$6^3 = 216$$

$$15^3 = 3375$$

Hence for 12: $12^3 = 1728.$

C = 1728

Column 1	Column 2	Column 3	Column 4
4	15	6	216
22	483	15	3375
11	120	3	27
7	48	12	1728

Hence the sum of A, B and C is: $48 + 12 + 1728 = 1788.$

Hence, option d is the correct answer.

10. Every column follows a certain rule. What number should come in place of “?”

CL1	CL2	CL3	CL4
16	28	25	12
9	7	16	27
12	14	20	?

a) 17

b) 18

c) 19

d) 21

Answer: b

Solution:

Step 1: Observe the pattern

Look at each column and check how the bottom number is formed using the top and middle numbers.

Step 2: Test the pattern with known columns

- **Column 1:**
Top = 16, Middle = 9
 $16 \times 9 = 144$
 $\sqrt{144} = 12$
- **Column 2:**
Top = 28, Middle = 7
 $28 \times 7 = 196$
 $\sqrt{196} = 14$
- **Column 3:**
Top = 25, Middle = 16
 $25 \times 16 = 400$
 $\sqrt{400} = 20$

Step 3: Identify the rule

Bottom number = $\sqrt{\text{Top} \times \text{Middle numbers}}$

Step 4: Apply the rule to Column 4

Top = 12, Middle = 27

$12 \times 27 = 324$

$\sqrt{324} = 18$

Therefore, option b is correct.



The Thinking Spot

Boxes are stacked in four columns A, B, C, and D, such that:

- Each box is labelled with a number from 1, 2, and 3, with labels on some of the boxes already shown in the image given below
- No two adjacent boxes in the same column are labelled with the same number
- No two adjacent columns have the same number on the topmost box
- For every column, the sum of the numbers labelled on the topmost and bottommost block is equal

In the shaded boxes, which of these numbers will occur the HIGHEST number of times?

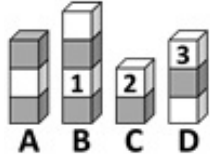

a) 1

b) 2

c) 3

d) All of them occur equally

Answer: b

Solution:

In column C, the shaded block cannot have 2 again, as no two adjacent blocks of a column have the same number.

Also, if this block has 1, then the sum of the topmost and the bottommost block of this column will be $2 + 1 = 3$.

But this cannot be a possible sum because, in that case, all the columns must have the same sum and column D already has 3 on the top and one more number in this column will add up to a sum greater than 3.

So, the shaded block of column C cannot have 1 or 2. Hence, it definitely has 3.

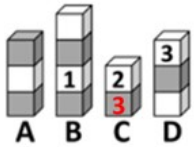

By this, we can say that the sum of the topmost and bottommost blocks of each stack is 5.

Thus, column D will have 2 in the bottommost block (as $3 + 2 = 5$).

Also, the middle block can have only 1, as 2 and 3 are adjacent to this block already.

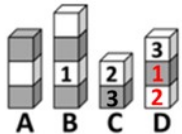

Now, column B cannot have 1 as the topmost block, as the bottommost block cannot have 4 to satisfy the sum.

Also, 2 cannot be present as well, as the topmost block of its adjacent column is already 2 (Column C).

Hence, we can have only 3 here and the bottommost block will automatically have 2.

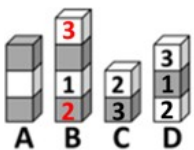

Now, the empty shaded block of column B is adjacent to both 3 and 1.

Hence, this block will have 2.

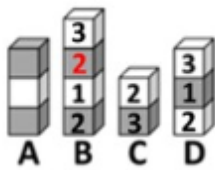

Now, column A will have 2 as the topmost block and 3 as the bottommost block (based on the topmost and bottommost blocks of column B).

After filling in the rest of the numbers, the final arrangement looks like the one given below.

Hence, 2 occurs the highest number of times (3 times) in the shaded blocks.

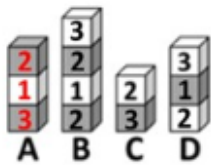

Option b is the answer.



Chapter 2: Power Play

1. Each term is written in exponential form. If the terms are rearranged in ascending order of their numerical values from left to right, how many terms remain in the same position as in the original arrangement?

Left $4^3, 2^4, 3^3, 2^8, 5^2, 3^6$ Right

- a) 0 b) 1 c) 2 d) 3

Answer: c

Solution:

The given values are: 64, 16, 27, 256, 25, 729

The ascending order is: 16, 25, 27, 64, 256, 729

Hence, when they're arranged in ascending order, **only two terms** appear in the same position in the new arrangement, as shown in the image below:

Left $4^3, 2^4, 3^3, 2^8, 5^2, 3^6$ Right

Ascending order $2^4, 5^2, 3^3, 4^3, 2^8, 3^6$

Option c is the correct answer.

-
2. What will come in place of “?” in the given series?

6, 26, 126, 626, ?

- a) 3125 b) 3126 c) 926 d) 916

Answer: b

Solution:

Each term is formed by **taking a consecutive power of 5 (starting from 5^1) and adding 1.**

$$5^1 + 1 = 6,$$

$$5^2 + 1 = 26,$$

$$5^3 + 1 = 126,$$

$$5^4 + 1 = 626.$$

Similarly, $5^5 + 1 = 3126$.

Hence, option b is the correct answer.

-
3. A team is to be formed from a group of 7 students: A, B, C, D, E, F, and G where:

- A and B cannot be in the same team, but at least one of them must be included in the team
- C and D must either both be included or both be excluded from the team
- E and F must either both be included or both be excluded from the team

If the team consists of 4 students, in how many different ways can it be formed?

- a) 2 b) 4 c) 3 d) 6

Answer: b

Solution:

Either A or B has to be in the team. Therefore, the combinations are:

A _ _ _ _

B _ _ _ _

Now, either C and D, or E and F can be placed in a team. Thus, 2 more members of the team are fixed which are either C and D, or E and F. Therefore, the combinations are:

A C D _

A E F _

B C D _

B E F _

The fourth person in the four combinations above will be G.

Therefore, the team can be formed in 4 different ways. Option b is correct.

4. Let X, Y, and Z be single-digit whole numbers. The number XY is a two-digit number formed using digits X and Y.

If $4000 < (XY)^Z < 5000$, what is the minimum possible value of XY?

a) 10

b) 16

c) 17

d) 15

Answer: b

Solution:

To make a number lie between 4000 and 5000, the base and power must balance each other.

If the base is larger, the power must be smaller and vice versa.

Since we want the minimum possible value of XY, we should try to keep the power as large as possible.

So, let's start with the largest possible power.

1) $Z = 4$

The smallest possible two-digit number is 10.

$$10^4 = 10000$$

This is greater than 5000, so it does not satisfy the condition.

Therefore, power 4 is not possible.

2) Try, $Z = 3$

Now check the cubes of two-digit numbers.

$$15^3 = 3375 \text{ (less than 4000)}$$

$$16^3 = 4096$$

Since 4096 lies between 4000 and 5000, this satisfies the condition.

Thus, the minimum possible value of XY is 16. Option b is correct.



5. Raj must select three numbers from the grid from three DISTINCT shapes such that:

1. Each number is chosen from a different row

2. The number selected from Row R1 is the n th power of 3

3. No digit is repeated among the bases and exponents of the chosen numbers

Based on these rules, what is the sum of the three selected numbers?

R1   

R2   

R3   

a) 1881

b) 7968

c) 1482

d) 1100

Answer: c

Solution:

Each number has to be chosen from a different row and a different shape.
So, we have to take the numbers from a pentagon, a square, and a circle.
The number chosen from R1 must be a power of 3
It can either be 3^4 or 3^6 .

Either circle or square is chosen.

Hence, the pentagon cannot be taken from R1.

As we have a pentagon again in R3, the number chosen from R3 is definitely from the pentagon.

As it is mentioned that no digit can be common among the bases and powers of the chosen numbers and we are already taking a power of 3 from R1, our number from R3 must be from a pentagon, but cannot have 3 again.

Hence, **the number chosen from R3 is 2^7 .**

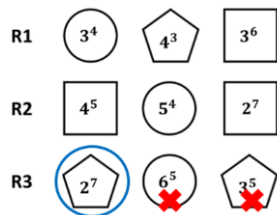

Now, as we have 2^7 from R3, we cannot again select 2^7 from R2.

We can either have 4^5 or 5^4 from R2

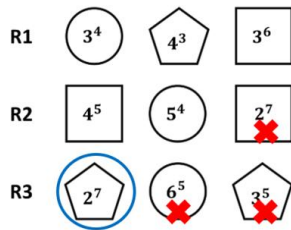

If we choose 4^5 from R2, we must take 3^6 from R1 (as digits cannot repeat).

But, this will give us numbers from two squares and a pentagon only.

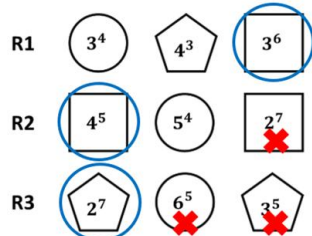

So, we have to **select 5^4** (from the circle) in **R2** and then proceed to the **square from R1**.

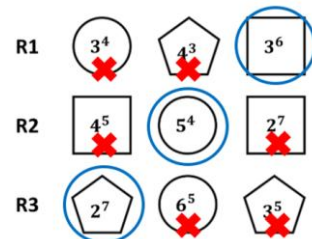

Thus, the total value of the numbers selected is: $3^6 + 5^4 + 2^7$
 $= (3 \times 3 \times 3 \times 3 \times 3 \times 3) + (5 \times 5 \times 5 \times 5) + (2 \times 2 \times 2 \times 2 \times 2 \times 2)$
 $= 729 + 625 + 128$
 $= 1482$

Option c is the correct answer.

6. A man has a bag with a maximum capacity of 2^4 units. He earns certain points for the books he carries in that bag and the load of each book is shown in the table below:

- For every Management book added to the bag, 2 Fiction books must be added
- For every Mathematics book added to the bag, 2 Physics books must be added

If he has to carry at least one book of each genre, what is the maximum number of points he can earn without exceeding the bag's capacity?

BOOK GENRE	LOAD	POINTS
Management	2^2	2^5
Mathematics	2^1	2^4
Physics	2^0	2^3
Fiction	2^0	2^2

a) 116

b) 120

c) 112

d) 104

Answer: b

Solution:

First, let's simplify the power numbers and find the load and points of each book:

Management: load 4, points 32

Mathematics: load 2, points 16

Physics: load 1, points 8

Fiction: load 1, points 4

Conditions:

- At least 1 of each genre must be carried.
- For every 1 Management, he must carry 2 Fiction books, and for every 1 Mathematics, he must carry 2 Physics books.
- Total load must be less than or equal to 16. (since the capacity of the bag = $2^4 = 16$)

So, the minimum compulsory load is 1 Mathematics and 1 Management, and with these, he automatically carries 2 Physics and 2 Fiction.

Minimum load = 1 (4) + 1 (2) + 2 (1) + 2 (1) = 4 + 2 + 2 + 2 = 10

So, the minimum points earned = 32 + 16 + 2(8) + 2(4) = 32 + 16 + 16 + 8 = 72

As 10 out of 16 units are already filled in the bag, the remaining load = 6 units.

Use the remaining capacity optimally. Compare efficiency (points per unit load):

Physics: 8 per unit load (Good)

Fiction: 4 per unit load (Not preferable - Low value)

Management: 8 per unit load, but adds 2 units for fiction books, with only 8 extra points

Mathematics: 8 per unit load (Good)

Case A: Add 1 more Mathematics book (for which 2 more Physics books are required)

Total load added = 2 + 2 = 4 (still 2 more units remaining).

We can fill them with 2 more Physics books (we cannot add another Mathematics book - it needs 2 extra Physics books, which exceeds the load)

Total points earned = Initial minimum points + Points added further (1 math + 4 physics)
 = 72 + 16 + 8 + 8 + 8 + 8
 = 120

Case B: Add only Physics books further.

To fill in the remaining capacity of 6 units, we can have 6 physics books.

Total points earned = Initial minimum points + Points added further (6 physics)
 = 72 + 8 + 8 + 8 + 8 + 8 + 8
 = 120

In any case, the maximum number of points that can be reached = 120.

Hence, option b is the right answer.

7. How many possible combinations of 1 owl and 1 tree can be made from 3 owls and 5 trees?

- a) 9 b) 10 c) 15 d) 16

Answer: c

Solution:

We need to make a combination of 1 owl and 1 tree.

There are 3 owls and 5 trees.

- The 1st owl can be paired with all 5 trees = 5 combinations
- The 2nd owl can also be paired with all 5 trees = 5 combinations
- The 3rd owl can also be paired with all 5 trees = 5 combinations

Total combinations = $5 + 5 + 5 = 15$

So, 15 different pairs of 1 owl and 1 tree can be formed.

Hence, option c is the correct answer.

8. Sam has Rs. 4000 in such a way that he has Re. 1 coins in power of 10, Rs. 2 coins in power of 5, Rs. 5 coins in power of 2, and the remaining coins of Rs. 10. The amount of money of each individual denomination of Re. 1, Rs. 2, and Rs. 5 is greater than or equal to thousand. At **MAXIMUM**, how many coins of Rs. 10 can he have?

- a) 53 b) 47 c) 38 d) 45

Answer: b

Solution:

Step 1: Represent the amount from each type of coin

Sam has:

Re. 1 coins in powers of 10: amount = 1×10^n

Rs. 2 coins in powers of 5: amount = 2×5^m

Rs. 5 coins in powers of 2: amount = 5×2^k

Rs. 10 coins = t (we need to find t)

The total amount is Rs. 4000.

So, $10^n + (2 \times 5^m) + (5 \times 2^k) + 10t = 4000$

Step 2: Find combinations where the amount is greater than or equal to Rs. 1000 for each coin type

The amount of money from each denomination of Re. 1, Rs. 2, and Rs. 5 must be greater than or equal to Rs. 1000. To maximize the number of Rs. 10 coins, we choose the smallest possible amount for each of these denominations, that is at least Rs. 1000.

That means:

Amount in Re. 1 coins = 1000 or more

Amount in Rs. 2 coins = 1000 or more

Amount in Rs. 5 coins = 1000 or more

Step 3: Determine the LEAST possible number of coins of each type, to MAXIMIZE the number of Rs. 10 coins.

(i) Re. 1 coins in powers of 10:

$$10^3 = 1000$$

So, $10^n = 1000$

Hence, the least possible number of Re. 1 coins = 1000 [Amount = Rs. 1000]

(ii) Rs. 2 coins in powers of 5:

$$2 \times 5^3 = 2 \times 125 = 250 \text{ (less than 1000)}$$

$$2 \times 5^4 = 2 \times 625 = 1250 \text{ (greater than 1000)}$$

So, the least possible number of Rs. 2 coins = 625 [Amount = Rs. 1250]

(iii) Rs. 5 coins in powers of 2:

$$5 \times 2^7 = 5 \times 128 = 640 \text{ (less than 1000)}$$

$$5 \times 2^8 = 5 \times 256 = 1280 \text{ (greater than 1000)}$$

So, the least possible number of Rs. 5 coins = 256 [Amount = Rs. 1280]

Total so far = $1000 + 1250 + 1280 = 3530$

Remaining amount for Rs. 10 coins = $4000 - 3530 = 470$

$$10t = 470$$

$$t = 47$$

Hence, Sam can have 47 coins of Rs. 10 at maximum. Option b is the correct answer.

9. What will come in place of “?”

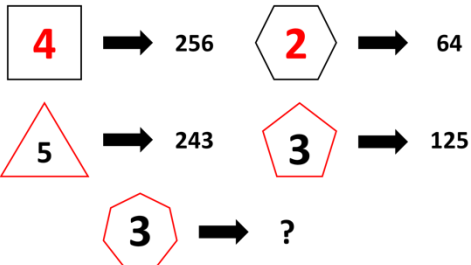

a) 243

b) 125

c) 343

d) 2187

Answer: c

Solution:

In the given question, if the polygon's border is black, the value after the arrow is equal to the number inside the polygon raised to the power of the number of sides of the polygon.

For example, 4 is in a black square, whose sides are 4.



So, the value after the arrow is $4^4 = 4 \times 4 \times 4 \times 4 = 256$

However, if the polygon's border is in red, then the number of sides is taken as the base and the number inside it is the exponent.



It will be $3^5 = 243$. (not 5^3 , as in black shape)

Similarly, in the question term, we have a red shape with 7 sides.



It will be $7^3 = 343$.

Therefore, option c is correct.

10. Sam and Tim are playing a number-maximizing game. Their numbers are shown in the table below (where A and B are undefined). They must modify their numbers using ONLY ONE of the following rules:

- If the base is smaller than the exponent, the base n is replaced with $1/n$
- If the base is greater than the exponent, the exponent n is replaced with $1/n$

Sam and Tim choose A and B and apply the rule exactly once in a way that maximizes their own numbers. What is the difference between the final numbers of Sam and Tim, where A and B are single-digit natural numbers?

Sam's number	4^A
Tim's number	B^2

a) 2

b) 3

c) 1

d) 0

Answer: c

Solution:

Sam's number is 4^A .

To maximize Sam's number, we use the rule:

If the base is greater than the power, the exponent n is replaced with $1/n$. (as 4 is already greater and choosing a power greater than 4 will change 4 to $1/4$ unnecessarily)

Here, the base 4 must be greater than the power A .

To keep the value as large as possible, we take the smallest natural value for the exponent, $A = 1$.

Applying the rule:

4^1 becomes $4^{(1/1)}$

$$4^{(1/1)} = 4$$

So, the maximum value of Sam's number is 4.

Now consider Tim's number = B^2 .

To maximize Tim's number, we choose the largest possible value of the base (as the power is 2, which is already a smaller number).

Since B is a single-digit natural number, the largest possible value is 9.

So, we take: 9^2

Here, base (9) > power (2), so the exponent is replaced with $1/2$.

9^2 becomes $9^{(1/2)}$

$$9^{(1/2)} = \sqrt{9} = 3$$

So, the maximum value of Tim's number is 3.

Difference between the numbers:

$$4 - 3 = 1$$

Hence, option c is the correct answer.



The Thinking Spot

Enter all the letters and the numbers of the Set in the empty squares of the grid given below, such that:

- Every vowel must have an even number in at least one of its adjacent squares
- The letter 'H' is not adjacent to 'A' or 6
- Two consecutive numbers cannot be in any adjacent squares

What will come in place of “?”

Note: Squares are considered to be adjacent only if they share a common side. Squares sharing a common corner are not considered adjacent

	5	
3	?	H

Set: A, E, Y, 2, 4, 6

a) 6

b) Y

c) E

d) A

Answer: c

Solution:

Among A, E, Y, 2, 4, 6, none of the digits can be placed in the top left corner cell, as no two consecutive digits can be adjacent. Also, every vowel must have at least one even digit adjacent to it. So, A and E also cannot be entered. Hence, the top left corner cell can have only 'Y'.

Y	5	
3		H

Similarly, only 2 can be placed in the top right corner cell, as A and E cannot be placed here, as vowels need an even digit next to them. Also, 4 and 6 are consecutive to 5 and cannot come in this cell.

Y	5	2
3		H

Now, H cannot have 6 or A adjacent to it.

So, 6 and A cannot come in place of the “?”.

Also, 4 cannot be placed here, as it is consecutive to both 3 and 5.

Hence, only E can come in place of the “?”.

Y	5	2
3	E	H

Hence, option c is the correct answer.

The final arrangement is as follows:

Y	5	2
3	E	H
A	6	4



Chapter 3: A Story of Numbers

Activity Time

Measure your Height

Introduction

We will explore the concept of the positional number system through hands-on activities. We will develop an intuition for various base representations of numbers by measuring students' heights, recognizing that decimal numbers that we learn in school are just one way to represent numbers.

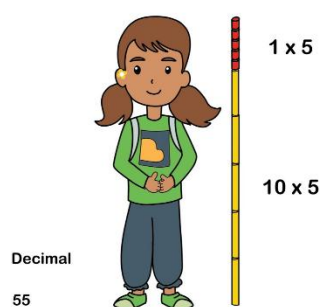
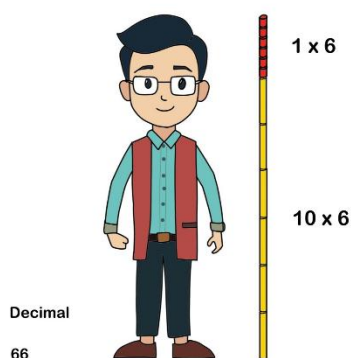

Activity	Time	Description
Launch	5 min	The teacher poses the question to the students and invite a couple of students to try their ideas. Supporting Links: Activity Video Link: https://youtu.be/bT_hDTvGA8 Reference:
Problem-solving and algorithm	25 mins	Student's Tryout the activity with each other. Student Worksheet: https://docs.google.com/document/d/1cycoY6rEfGqczQqfOrIneL_R_jWZEs9lryhfzjp23QqA/edit?tab=t.0 As the teacher progresses through the activities, the students progress along with the worksheet.
Discussions and Explorations	5 min	The discussion on the various algorithms, how a slight change in approach leads to a faster solution, and how computers apply such algorithms

CT Connection

Pattern recognition: Two see that the same patterns of representation appear in each of the base systems and the symbols used in them.

Algorithmic Thinking: We use a step-by-step approach to measure the height using the decimal, binary, and ternary pipes.

Decomposition: Breaking the conversion of the number to binary and ternary into one pipe at a time.

Abstraction: Two use the pattern seen in decimal and apply it to powers of two and powers of three.

Generalisation: Recognising a doubling pattern of 1, 2, 4, and so on, and adding different powers thus generated yields the binary representation; we conclude that any number can be represented in terms of powers of 2. Similarly, we see how to measure using ternary numbers. This method can thus be generalised for any natural number n .

Logic: To understand why the digits start from zero and end before the base number n (0 to $n - 1$)

Activity: Measuring your Height

1: Measuring your height with Decimal Pipes

We generally measure our height in the decimal number system, i.e., using base -10 numbers. We use powers of ten $10^0, 10^1, 10^2, 10^3, \dots$ (1, 10, 100, 1000, ...) and digits from 0 to 9 (ten distinct symbols), to represent any number that exists.

Imagine now that you are measuring heights using PVC pipes of fixed lengths:

1 inch, 10 inches, 100 inches, and so on.

Each pipe size is a power of 10. You also have 9 pipes of each length.

 1 **Decimal**

 10

1. How many of the decimal pipes will it take to measure the height of a 66-inch-tall person?

- a) 21 pipes: 5 pipes of 10 inches height and 16 pipes of 1 inch height
- b) 7 pipes: 7 pipes of 10 inches height
- c) 9 pipes: 6 pipes of 10 inches and 3 pipes of 2 inches height
- d) 12 pipes: 6 pipes of 1 inch and 6 pipes of 10 inches

Answer: d

Solution:

66 in decimal notation is represented as $6 \times 10 + 6 \times 1$, that is, 6 of 10s and 6 of 1s, for a total of 12 pipes.

Competencies: Algorithmic thinking, logic, decomposition

2: Measuring your height with binary pipes

We keep hearing that the language of computers is binary, the language of 0 and 1. But what are these binary numbers? How do we understand these in light of what we already know?

Instead of using decimal pipes, which are powers of 10, what happens if we use pipes of length 1, 2, 4, 8, 16, 32, 64, and so on? What is special about these numbers?

They are powers of 2. We have exactly one copy of each pipe length. We will call these pipes Binary pipes.

Binary

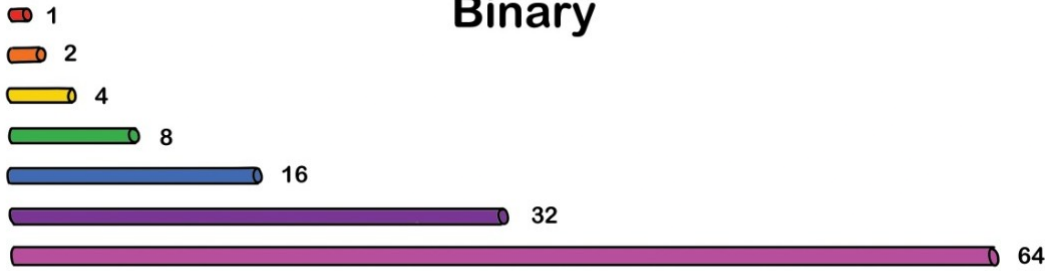

We have only one copy of each pipe for the following reason. Two 2-inch pipes make a 4-inch pipe, but we already have a 4-inch pipe. Two pipes of 4 inches make an 8 inches pipe, but we already have an 8-inch pipe; likewise, we can do this for pipes of all lengths.

Let's measure a height in binary. For example, $55 = 32 + 16 + 4 + 2 + 1$.

We will see that if we keep a 64-inch pipe, it's more than the height we are measuring, so we don't use a 64-inch pipe. We use the next lower power of 2, 32. We then keep 16, the next lower power. We then keep the next lower power of 2, which is 8, but this is more than the height we are measuring. So, we don't use it and move on to the next power of 2. This process continues.

We can tabulate the information below. Using this, we can say that the binary representation of 55 is $(110111)_2$.

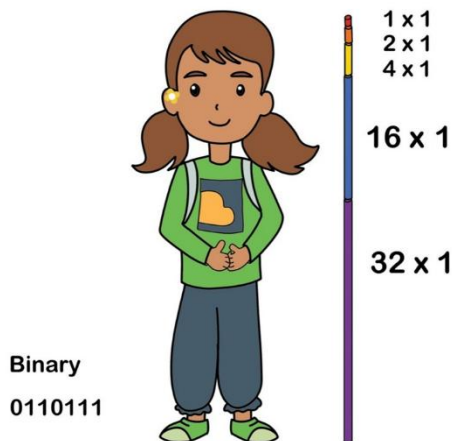

55 in binary	$2^5=32$	$2^4=16$	$2^3=8$	$2^2=4$	$2^1=2$	$2^0=1$
$(110111)_2$	1	1	0	1	1	1

1. Which all binary pipes will we use to measure the height of a 66-inch-tall person?

- a) 63, 3
- b) 32, 16, 8, 4, 2, 1, 2, 1
- c) 64, 2
- d) 32, 32, 2

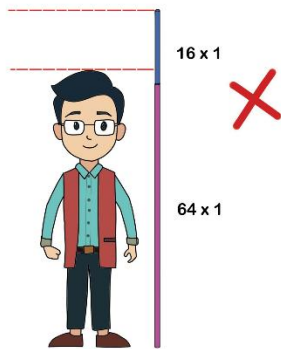

Answer: c

Solution:

Let's understand what is happening. We first place a 64-inch-tall block. Now, when we try to keep the other heights over 64 inches, like 32, 16, 8, 4, etc., we will see that these heights will exceed the height we have to measure. So, we pick the next lower height until we reach the one that fits. In the number 66, we have 1 copy of 64, 0 copies of 32, 0 copies of 16, 0 copies of 8, 0 copies of 4, 1 copy of 2, and 0 copies of 1. If we write this information in the same way we write place values for decimals, we get:

$2^7=128$	$2^6=64$	$2^5=32$	$2^4=16$	$2^3=8$	$2^2=4$	$2^1=2$	$2^0=1$
0	1	0	0	0	0	1	0

Thus, 66 in decimal in binary representation is $(1000010)_2$. We write a $(---)_2$, subscript 2 to tell us that this is a base 2 representation of a number.

Competencies: algorithmic thinking, decomposition, abstraction, generalisation, pattern recognition

2. Binary representation of 10 is:

- a) 1010 b) 1111 c) 1000 d) 1100

Answer: a

Solution:

We can draw a table similar to the one shown above and list which powers of 2 can be added to get 10.

2^3	2^2	2^1	2^0
1	0	1	0

Thus, $10 = 1 \times 8 + 1 \times 2 = (1010)_2$.

Competencies: algorithmic thinking, abstraction, generalisation, pattern recognition

3. Why can't we use the digit "2" in the representation of a number in binary?

- a) It is illegal, as only 0 and 1 are given to us in the rules
 b) We can write any number using 0 and 1; there is no need for 2
 c) Computers dislike it
 d) It is too big

Answer: b

Solution:

If we used the digit “2” in the binary system in the ones place, it would denote $2 \times 1 \text{ inch} = 2$ inches. But this is equivalent to using one 2-inch block, which is already present among the height blocks. This means redundancy.

That is why digits must be less than the base. Similarly, two blocks of 4 inches make 8 inches, but we already have an 8-inch block; likewise, two 8 inches is 16 inches, and there is already an 16 inches block

Competencies: abstraction, generalisation, pattern recognition, logic

3: Measuring your height with ternary pipes

Instead of base 10 (decimal) and base 2 (binary), what if we set the base to something else, for example, 3?

Then we will have pipes of lengths 1, 3, 9, 27, 81..., all powers of 3, and 2 pipes of each length.



Let's see an example of measuring 55 inches in height in ternary.

We will see that if we keep the 81-inch pipe, it's taller than the height we are measuring, so we don't use it. We use the next lower power of 3, 27. We keep two of these, which is the maximum number of pipes of each type allowed.

We then keep 2 pipes of 9, the next lower power, but this overshoots the height, so we remove one pipe. Even with one 9-inch pipe, we are still over the height we are measuring.

So, remove this pipe and keep two 3-inch pipes. But this overshoots the height, so we remove one pipe. Even with one 3-inch pipe, we are still over the height we are measuring.

So, we remove that and keep two pipes of the next lower power of 3, which is 1, but this is more than the height we are measuring. So, we remove one pipe and see that we get the correct height measurement. 55 inches is $54 + 1 = 2 \times 27 + 1 \times 1$.

55	3^3	3^2	3^1	3^0
$(2001)_3$	2	0	0	1

1. When we measure 66 inches with ternary pipes, how will its representation be?

- a) 2011 b) 2101 c) 2110 d) 2210

Answer: c

Solution:

To measure 66 inches, we use two 27-inch pipes, one 9-inch pipe, one 3-inch pipe, and zero 1-inch pipes.

$$66 = 2 \times 27 + 1 \times 9 + 1 \times 3 + 0 \times 1 = (2110)_3$$

66	3^3	3^2	3^1	3^0
$(2110)_3$	2	1	1	0

Competencies: algorithmic thinking, decomposition, abstraction, generalisation, pattern recognition

2. What is the largest digit allowed in Base 3?

- a) 3 b) 2 c) 1 d) 9

Answer: b

Solution:

As we saw in other representations, the digits allowed in a base number system are numbers less than the base. In case 3, we have three numbers: 0, 1, and 2.

Competencies: abstraction, generalisation, pattern recognition, logic

3. How will we write 100 in base 3 (ternary) notation?

- a) $(3201)_3$ b) $(2333)_3$ c) $(11000)_3$ d) $(10201)_3$

Answer: d

Solution:

$$100 = 1 \times 81 + 0 \times 27 + 2 \times 9 + 0 \times 3 + 1 \times 1 = (10201)_3$$

100	3^4	3^3	3^2	3^1	3^0
$(10201)_3$	1	0	2	0	1

Competencies: algorithmic thinking, decomposition, abstraction, generalisation, pattern recognition

Conclusion

We see that a number can be represented in many forms and symbols. Decimal notation is one of the many possible base number systems (Positional value system).

The fundamental idea is that we arrange the powers of the base number n in increasing order from right to left.

The face value at each place tells us how many times the corresponding power of the base is used to represent the number.

We also see that the base n system requires n distinct digits. These digits are 0 till n - 1.

Questions

1. Some terms are missing in between the sequence. Find the missing terms in the order from left to right. VII, VI, VI, VII, V, VIII, _____, _____, III, X

- a) VI, IX b) V, VIII c) IV, IX d) IV, V

Answer: c

Solution:

The sequence is written in Roman Numerals. The sequence is formed by two alternate series. VII, VI, V, _____, III and VI, VII, VIII, _____, X.

So, the missing terms will be IV and IX.

Roman Numerals	VII	VI	VI	VII	V	VIII	IV	IX	III	X
Hindu-Arabic Numerals	7	6	6	7	5	8	4	9	3	10



Thus, option c is correct.

2. Find the odd one out from the following:

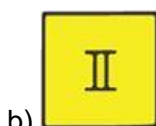

a)

b)

c)

d)

Answer: c

Solution:

Option a: The Roman number is 1 and the shape has three sides.

Option b: The Roman number is 2 and the shape has four sides.

Option c: The Roman number is 3 and the shape has six sides.

Option d: The Roman number is 3 and the shape has five sides.

The value of the Roman number in every shape is two less than the number of sides in that shape, except in option c.

Hence, option c is the correct answer.

3. In each of the given options, the weight of one bag is written in the Roman numeral form and that of the other bag is in Hindu - Arabic form. Identify the option that displays the tilt of the balance correctly.

Note: The balance tilts towards the larger weight

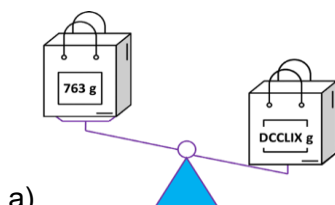

a)

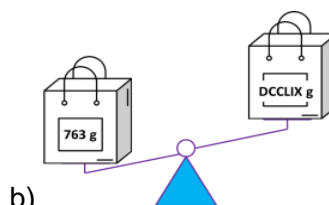

b)



c)

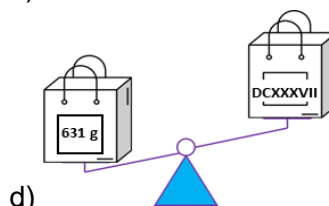

d)

Answer: b

Solution:

We first convert the Roman numeral to Arabic form and then compare the numbers:

The following table shows the relation between Hindu - Arabic numerals and Roman numerals:

Hindu – Arabic numeral	1	5	10	50	100	500	1000
Roman numeral	I	V	X	L	C	D	M

Also, a Roman numeral of smaller value when written on the right of a Roman numeral of greater value is added to the Roman numeral of greater value.

Example: VI = 5 + 1 = 6, where I (1) written to the right of V (5) is added to it.

And a Roman numeral of smaller value when written on the left of a Roman numeral of greater value is subtracted from the Roman numeral of greater value.

Example: IV = 5 – 1 = 4, where I (1) written to the left of V (5) is subtracted from it.

Therefore, DCCLIX can be expressed as 500 + 100 + 100 + 50 + 9 = 759 and

DCXXXVII can be expressed as 500 + 100 + 10 + 10 + 10 + 7 = 637.

Now, let's check each of the given options:

Option a: 763 < DCCLIX

763 < 759 (Incorrect)

Option b: 763 > DCCLIX

763 > 759 (Correct)

Option c: 631 = DCXXXVII

631 = 637 (Incorrect)

Option d: 631 > DCXXXVII

631 > 637 (Incorrect)

Hence, option b is correct.

4. On the abacus, select two poles, A and B, where pole B has fewer beads than pole A. Exactly one bead from pole A must be moved to pole B. If more than one pole has fewer beads than A, move the bead to the pole that has the maximum number of beads among those poles. After making this single move, what is the highest possible 6-digit number that can be formed?

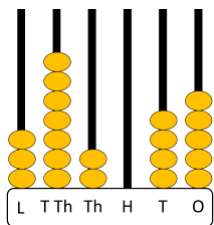

a) 3,62,046

b) 4,72,035

c) 4,72,046

d) 4,62,045

Answer: b

Solution:

The current number is 3,72,045.

We must move EXACTLY one bead from pole A to pole B, which has fewer beads than A.

If there are multiple such poles, we must place it on the pole that has the highest number of beads among them.
 To make the largest number, we should try to move a bead to the pole of Lakhs value.
 For this, if we choose a bead from the ten thousands' pole, we have to move it to the ones pole, which gives a result of 3,62,046.

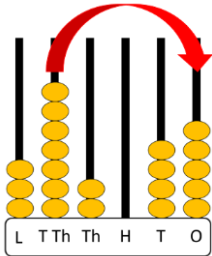

However, if we choose the tens pole (which has 4 beads), we can move the bead to the Lakhs pole (which has 3 beads, which is the highest count among the poles having fewer beads than the tens pole).

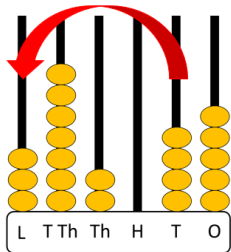

Thus, the final answer is 4,72,035.
 Option b is the correct answer.

5. What will come in place of “?”

Note: All the numerals on the left of each term are from the same number system

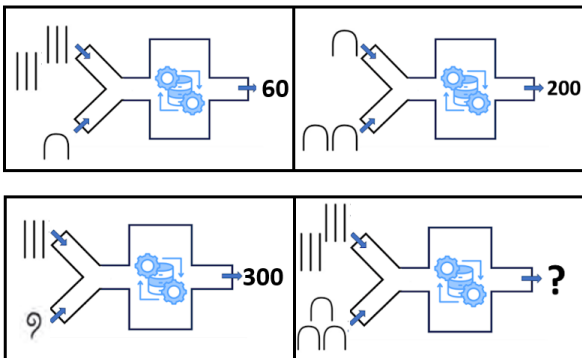

- a) 18
- b) 90
- c) 36
- d) 180

Answer: d

Solution:

Here, the Egyptian numerals are considered

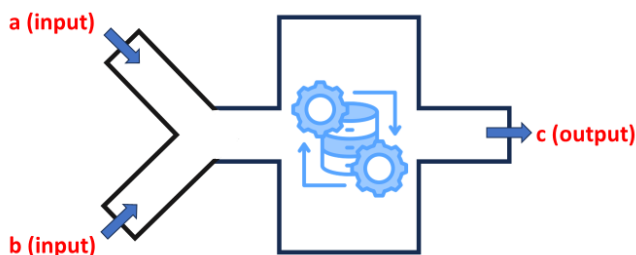

The individual numbers are added first and then sent as input.

'c' is obtained by multiplying the inputs.

For example, in the first term, we have input 'a' as $3 + 3 = 6$

Input 'b' = 10

So, c is obtained by multiplying a and b, $6 \times 10 = 60$.

Likewise, in the question term, input a = $3 + 3 = 6$

Input b = $10 + 10 + 10 = 30$

$c = a \times b = 6 \times 30 = 180$.

Option d is the correct answer.

6. A 3 - digit code is formed using Chinese numerals (Zongs) and Roman numerals. Each row represents a guess, along with a statement describing how correct the guess is. Using these clues, determine the correct code.

IX	V	Π	One digit is correct but incorrectly placed and incorrect numeral
----	---	---	-------------------------------------------------------------------

ΠΠ	I	T	One digit is well placed but wrong numeral
----	---	---	--------------------------------------------

III	VIII	II	No digit is correct
-----	------	----	---------------------

Π	VI	IIII	Two digits in the right numerals are correct but in the wrong positions.
---	----	------	--------------------------------------------------------------------------

II	III	IV	One correct digit at incorrect position and incorrect numeral
----	-----	----	---------------------------------------------------------------

a)

V	IIII	T
---	------	---

b)

IIII	IIII	VI
------	------	----

c)

IIII	Π	VI
------	---	----

d)

IIII	IIII	T
------	------	---

Answer: b

Solution:

From the third hint, we know 3 (in Roman numeral), 8 (in Roman numeral), and 2 (in Chinese numeral) are not part of the code.

III	VIII	II	No digit is correct
----------------	-----------------	---------------	---------------------

From the second hint, we know that among 8 (in Chinese numerals), 1 (in Chinese numerals), and 6 (in Chinese numerals), one of them is in the correct position, but it will appear in Roman numerals.

Since 8 is not present in the secret code, only 1 and 6 can possibly be in the code.

III	I	T	One digit is well placed but wrong numeral
----------------	---	---	--------------------------------------------

In the fifth hint, among 2, 3, and 4, only one digit is correct. Since 2 and 3 are not part of the code, 4 must be part of the code.

However, it is in the incorrect position and also in the incorrect numeral system. Hence, 4 must be written in Chinese numerals.

IIII	IIII	
------	------	--

Possible positions of 4 (Chinese numeral)

In the first and fourth hints, the common digits are 5 and 7.

In Hint 1, 7 appears as a Chinese numeral in the units place, but the hint states that it is in the wrong position and the wrong numeral. Therefore, if 7 were part of the code, it would have to be written in Roman numerals.

In Hint 4, 7 appears as a Chinese numeral in the hundreds place, and the hint indicates that the numeral type is correct. Since this contradicts the earlier conclusion about the numeral type of 7, it follows that 7 is not part of the code.

According to Hint 1, 5 should be in Chinese numerals and placed either in the hundreds or units position. Hint 4 states that two digits are in the correct numeral but in the wrong positions. Since 7 is not part of the code, the remaining digits must be 5 and 6, confirming that both are part of the code.

Combining Hints 1 and 4, 5 must be in the hundreds position and written in Chinese numerals.



Final Code

Digit 6 is also part of the code, and the only remaining position for it is the units place.

Hint 4 indicates that the numeral type of 6 should be Roman numerals.

Hence, the final code will be:



Final Code

Hence, the correct answer is option b.

7. If certain numbers are coded as shown in the image, what would be the code for 208?

Number	Code
1	I
3	○
12	△○
34	□○○I
87	▽○○



Answer: a

Solution:

The symbols in the code add up to the original number, with 1 and 3 defined at the beginning.

From the first code, we know that 1 is coded as I and 3 is coded as a circle. In the code for 12, the circle anyways represents 3, and $12 - 3 = 9$.

Hence, the code for 9 is an upward triangle.

In the code for 34, we know that a circle represents 3 and I represents 1.

So, the value of two circles and one I is: $3 + 3 + 1 = 7$.

Therefore, $34 - 7 = 27$, which is the value represented by the square.

In the code for 87, two circles represent 6, so the remaining value is 81 ($87 - 6 = 81$), which is coded as an inverted triangle.

So, the values of the shapes are: 1, 3, 9, 27, 81.

The original number is coded into the above numbers, represented by the shapes. (these shapes add up to the number)

The code appears to follow numerals with base 3, where:

$$3^0 = 1, 3^1 = 3, 3^2 = 9, 3^3 = 27, 3^4 = 81.$$

Hence, the code for 208 will be:

208 can also be written as: $81 + 81 + 27 + 9 + 9 + 1$, which in code will be written as:



Hence, the correct answer is option a.

8. Two 2-digit numbers are represented below by stacking balls on poles. If you can shift/move EXACTLY ONE ball from a pole to any of the other three poles, what will be the MINIMUM possible difference between the numbers, finally?

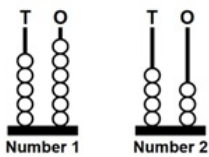

- a) 1 b) 2 c) 11 d) 13

Answer: b

Solution:

The numbers shown are 56 (5 tens, 6 ones) and 43 (4 tens, 3 ones). To get the smallest possible difference, we should try to make their tens digits closer, because tens change the value the most.

There are two effective moves:

Take 1 ball from the tens pole of 56 and add it to the ones pole of 43.

New numbers: 46 and 44. So, Difference = 2.

Take 1 ball from the ones pole of 56 and add it to the tens pole of 43.

New numbers: 55 and 53. So, Difference = 2.

In both cases, the minimum possible difference is 2.

Hence, option b is correct.

9. Sam wants to create a 4-digit password using the buttons (Chinese numerals - Zongs) from the given screens. He must press the buttons in the same sequence as he wants the digits in the password to appear.

- Every next button pressed must have a greater digit than the previous button
- No two adjacent digits in the password can be selected from the same screen and from buttons of the same colour

How many different passwords can Sam form?

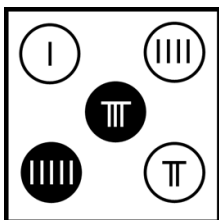

Screen 1

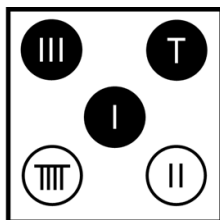

Screen 2

- a) 1 b) 2 c) 3 d) 4

Answer: c

Solution:

Digits in screen 1 and screen 2 have Chinese numerals, so let us first identify each digit:

Screen 1: Digits in white: 1, 4, and 7 & Digits in black: 5 and 8
 Screen 2: Digits in white: 2 and 9 & Digits in black: 1, 3, and 6
 As every next digit selected is greater than the previous digit, Sam must start with smaller digits only.
 As per the image, starting with a button 4 or more than 4, will not allow Sam to select digits in ascending order as well as alternate colours and screens. (as 4 is there in screen 1, if we start with 4, we can only have 4 from screen 1, 6 from screen 2, and 7 from screen 1. After this, the 4th digit of the password cannot be selected)
 The pattern of colour will be Black - White - Black – White, OR White - Black - White - Black.

CASE 1: Assume that Sam started with a black digit of Screen 1.

He must start with 5 only. As discussed above, the password cannot start with 4 or more than 4 (as 6 from screen 2 is also from a black button and cannot be chosen immediately after 5).
 So, this case is invalid.

CASE 2: Assume that Sam started with a white digit of Screen 1.

He can start with 1 only. (as the password cannot start with 4)
 If he starts with 1 from screen 1, the password could be **1 - 3 - 4 - 6**

CASE 3: Assume that Sam started with a black digit of Screen 2.

He can either start with 1 or 3 only.
Case 3 A: If he starts with 1, the password could be **1 - 4 - 6 - 7**
Case 3 B: If he starts with 3, the password could be **3 - 4 - 6 - 7**

CASE 4: Assume that Sam started with a white digit of Screen 2.

He can start with 2 only.
 After choosing 2 (white) from screen 2, he can choose only five (black) from screen 1. After this, there isn't any other suitable white button to be selected as the 3rd digit of the password (as 9 is the highest available number and cannot come in the 3rd place of the 4-digit number).
 So, this case is invalid.

Therefore, three different passwords can be formed: **1 - 3 - 4 - 6**, **1 - 4 - 6 - 7**, and **3 - 4 - 6 - 7**
 Option c is correct.

10. Rearrange the numbers in Set A into ascending order, as shown in Set B. The blocks can be rearranged only by swapping adjacent blocks. What is the MINIMUM number of swaps required to do this?

Note: Blocks that have common sides are considered to be adjacent. Blocks that have a common corner alone are not adjacent

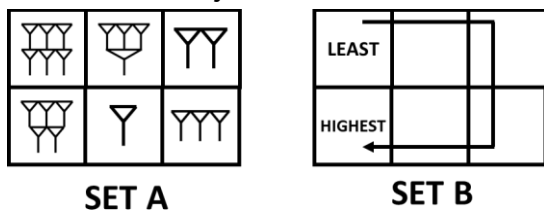

- a) 3 b) 4 c) 5 d) 6

Answer: b

Solution:

The Set A has digits in Mesopotamian numeral system.
 As we know:

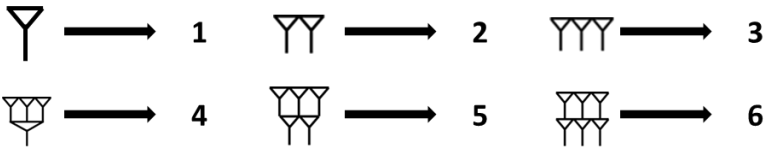

Thus, we substitute the values in Set A:

6	4	2
5	1	3

SET A

We need to rearrange Set A into ascending order as shown in Set B, using only swaps between adjacent blocks (blocks that share a common side).

Set A is:

6 4 2

5 1 3

Ascending order should be arranged from least to highest as:

1 2 3

4 5 6

Now we arrange step by step using minimum adjacent swaps.

First, we need to place 1 in the top-left box.

Currently, 1 is in the bottom middle.

To move 1 correctly:

- Interchange 1 and 5. Now, 5 moves toward its correct lower row position.

6	4	2
1	5	3

- Then, interchange 1 and 6. Now, 1 reaches the top-left position, and 6 shifts toward its correct side.

1	4	2
6	5	3

Next, we arrange the remaining numbers with minimum swaps.

- Interchange 2 and 4. Now, 2 moves closer to its correct position in ascending order.

1	2	4
6	5	3

- Then, interchange 3 and 4. Now, both 3 and 4 reach their correct ascending positions.

1	2	3
6	5	4

After these four adjacent swaps, all numbers are arranged in proper ascending order.

Therefore, the minimum number of swaps required is 4.

Hence, option b is the correct answer.



The Thinking Spot

As shown below, A, B, and C are positioned at different starting points on a circular track. B runs at half the speed of A, while C runs at twice the speed of A. If all three start running at the same time and in the same direction, what could be the positions of A and B by the time C completes one full round of the track?

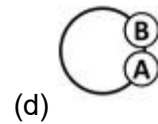
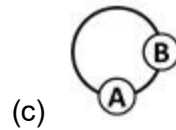
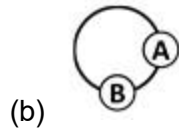
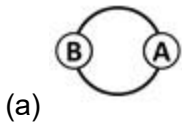
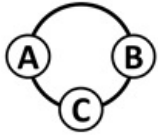

Answer: b

Solution:

Assume that A, B and C are running in a clockwise direction.

Step 1: Identify the distance that could be covered by each of them, based on the speed mentioned:

- C runs at twice the speed of A
If C completes one full round, A completes half the round.
- B runs at half the speed of A
If A completes half the round, B can finish only a quarter distance.

Step 2: Determine the final positions of A and B, assuming that C has finished one full round:

By the time C completes one full round, we know that A could finish only half the round. So, A appears exactly on the opposite side of his current position. (A's final position would be the same as B's current position).

Based on this, the options that show a different position for A, can be eliminated.

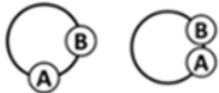

Option c Option d

Options c and d represent A's position at a point which is more than half the distance from A's current position.

Hence, options c and d are incorrect.

Also, we know that when A completes half the round, B should be able to cover only a quarter distance.

But, in option a, we can see that, B reached A's initial position, by the time A reached B's initial position.

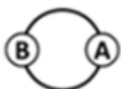

Option a

So, option a clearly shows that both A and B covered the same distance, which is also a contradiction.

Hence, option a is also incorrect.

As C finishes a round, A finishes half the round (and reaches B's initial position), and B finishes a quarter round (and reaches C's initial position), as shown in option b.

Hence, option b **is the correct answer**.



Chapter 4: Quadrilaterals

1. Raj colored the following shapes (Trapezium, Parallelogram, Square, Kite) in Red, Yellow, Green, and Blue, not necessarily in the same order.

- The shape colored in Red has no parallel sides
- The shape with each of its angles equal to 90° , is not Yellow
- The shape with two pairs of parallel sides is not Green

Which shape did he color in yellow?

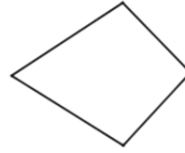
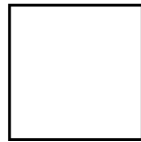
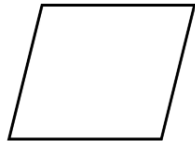
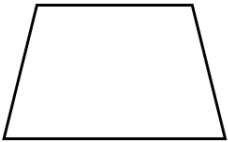

a) Trapezium

b) Parallelogram

c) Square

d) Kite

Answer: b

Solution:

-The shape coloured in Red has no parallel sides
In the given shapes, only 'Kite' has no parallel sides.
Hence, Raj coloured the Kite in Red.

-The shape with two pairs of parallel sides is not Green
In the given shapes, the shapes with two pairs of parallel sides are the Square and Parallelogram. So, they are not Green.
The Trapezium is green.

- The shape with each of its angles equal to 90° , is not Yellow
The square is not yellow
The Parallelogram is Yellow and the Square must be Blue
Hence, the Parallelogram is coloured in Yellow.
So, the correct answer is option b.

2. How many quadrilaterals are there in the given figure?

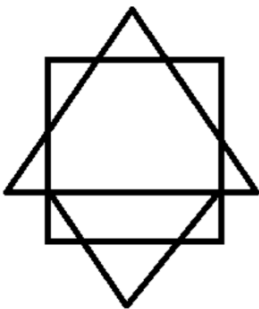

a) 8

b) 9

c) 10

d) 11

Answer: d

Solution:

There are 11 quadrilaterals as shown in the image:

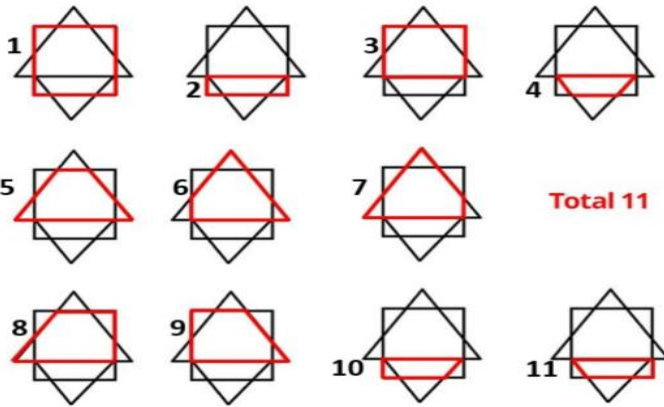

Option d is the correct answer.

3. How many rectangles are there in the given figure?

Note: For the purpose of this question, please count all squares also as rectangles

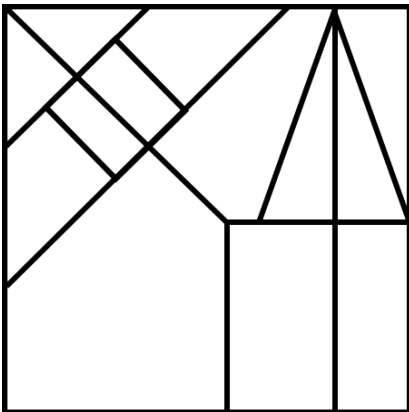

a) 8

b) 9

c) 10

d) 11

Answer: c

Solution:

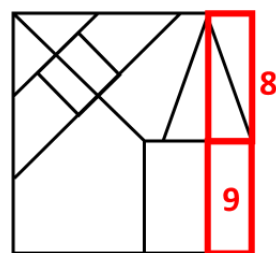
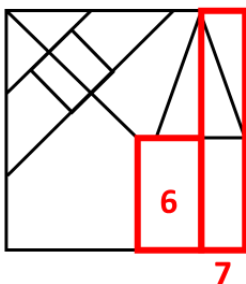
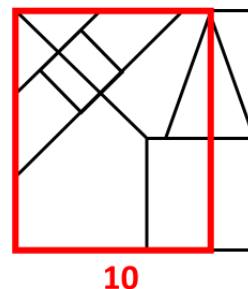
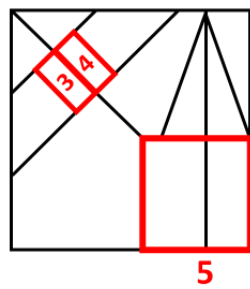
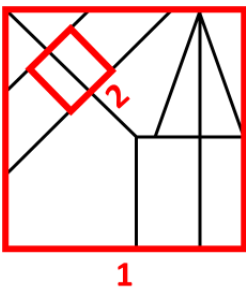

Hence, the correct answer is option c.

6. In the grid, each letter stands for the initial of a shape: Square, Rhombus, Kite, Trapezium, and Parallelogram. How many pairs of adjacent letters represent two shapes in which the diagonals bisect each other?

R K S P T R P S T P R S K

- a) 3 b) 4 c) 5 d) 6

Answer: c

Solution:

The shapes whose diagonals bisect each other are Square, Rhombus, and Parallelogram.

So, we only look for the letters S, R, and P in the grid.

Now check the grid and count the pairs where two of these letters are placed next to each other.

We find 5 such adjacent pairs in the grid.

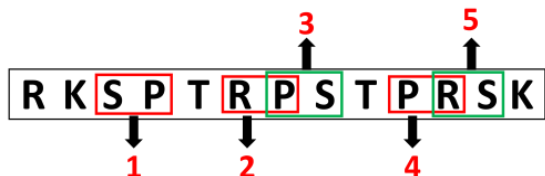

Hence, option c will be the correct answer.

7. Find the option that does NOT belong to the elements in the given set.

Set = (Angle between diagonals of a Rhombus, Each angle of a rectangle, Each angle of a square)

- a) Angle inscribed in a semicircle
 b) Half of sum of opposite angles of a Cyclic Quadrilateral
 c) Each angle of an Equilateral Triangle
 d) Angle opposite to Hypotenuse in a Right - Angled Triangle

Answer: c

Solution:

First, find the common value of the given set.

Set:

- Angle between diagonals of a rhombus = 90°
- Each angle of a rectangle = 90°
- Each angle of a square = 90°

So, all elements in the set are 90° .

Now check the options:

- a) Angle inscribed in a semicircle = 90°
 b) Half of the sum of opposite angles of a cyclic quadrilateral
 Opposite angles sum to 180° , half = 90°
 c) Each angle of an equilateral triangle = 60°
 d) Angle opposite the hypotenuse in a right-angled triangle = 90°

Option c does not belong to the set.

Hence, option c is the correct answer.

8. Which shapes from the given options will NOT form a quadrilateral when any two identical shapes are joined along any one of their sides?

Note: You can rotate the shapes but they cannot overlap each other

- a) Triangle b) Rhombus c) Trapezium d) Pentagon

Answer: d

Solution:

As shown below, **only the pentagon**, when joined along a side, will **never form a quadrilateral**.



2 Triangles 2 Rhombuses 2 Trapeziums 2 Pentagons

Option d is correct.

9. Two transparent sheets are shown below. Sheet A is a rectangle and Sheet B is a right-angled triangle. Rearrange the sheets so that the red points overlap exactly (without rotating or flipping the sheets). How many quadrilaterals are formed in the final figure?

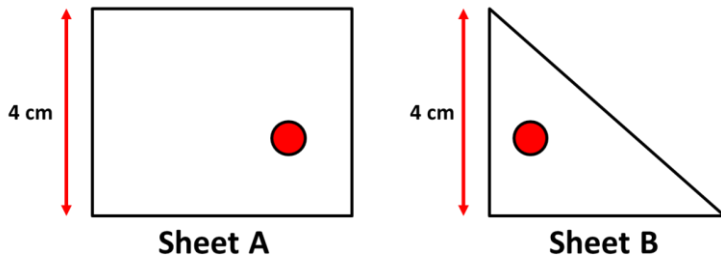

- a) 3 b) 4 c) 5 d) 6

Answer: c

Solution:

As shown in the figure below, when both the sheets overlap at the same red point, the final figure contains 5 quadrilaterals.

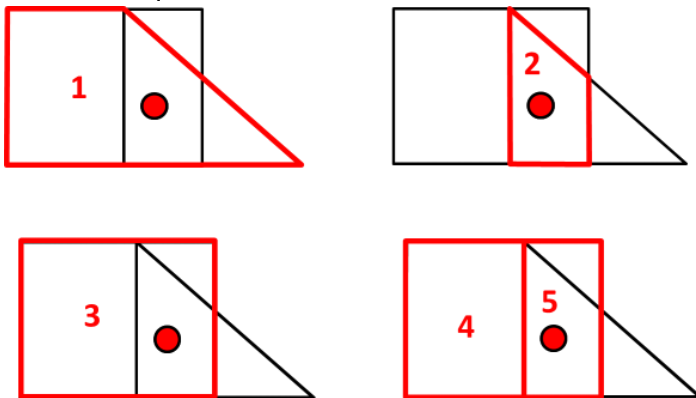

Therefore, the correct answer is option c.

10. Paul and Sam are at different positions and start walking in opposite directions but along parallel paths. After covering the same distance, each of them turns toward the starting point of the other person and walks straight (without taking any other turns) until they reach each other's starting points. What can we say for certain about the shape formed by BOTH their paths together?

- a) The shape of the paths is a rectangle b) It has no lines of symmetry
c) Opposite sides are of same length d) Both options a and c

Answer: c

Solution:

Paul and Sam walk on parallel paths starting from different positions, but in opposite directions.

After covering the same, both of them turn towards the starting point of the other person and walk straight until they reach the other's starting point.

There will be two possible cases for the starting positions. They can lie straight on the same vertical line or not on the same vertical line (diagonally placed).

If the starting points are not on the same vertical line (A and B as shown in the image below), a square/rectangular/parallelogram/rhombus is formed (based on the distance they walk):

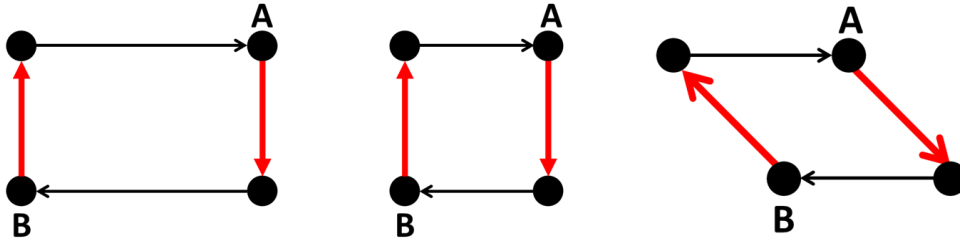

In the second case, when the starting points lie on the same vertical line, the figure formed is a parallelogram, where the opposite sides are parallel to each other, as shown in the image below:

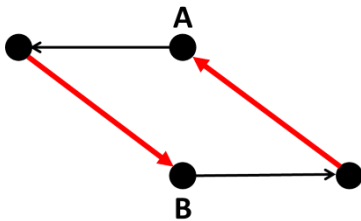

In any of the cases, we cannot confirm the exact shape formed. However, we can see that the opposite sides of the shapes are equal in any case.

Therefore, the correct answer is option c.



The Thinking Spot

Given below are two boards, X and Y. Clicking any circle on Board Y changes its colour from black to white, or white to black.

What is the **MINIMUM** number of clicks required to transform Board Y into the **MIRROR IMAGE** of Board X?

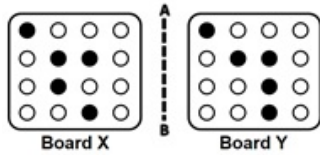

(a) 2

(b) 3

(c) 5

(d) 4

Answer: d

Solution:

Visualize and detect what the mirror image of board X looks like:

As we need to transform board Y to the mirror image of board X, first, we need to understand what the mirror image of board X looks like.

We know that, in a mirror image, the right side of the object appears on the left and vice versa.

So, the mirror image of board X looks like the one shown below:

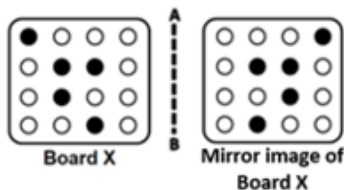

Compare board Y and the mirror image of board X:

• Check and determine which circles of board Y differ from those of the mirror image of board X.

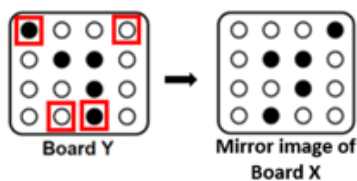

Clearly, we can see that there are two black circles in board Y that should actually be white, and two white circles that should actually be black, to get the mirror image of board X.

The other circles exactly match with the mirror image of board X. Hence, they need not be changed.

Determining the minimum number of clicks:

As it is mentioned that clicking a circle changes its colour from black to white and vice versa, we have to click each of the above highlighted circles of board Y once, to get the required pattern.

Hence, the minimum number of clicks required = 4

Therefore, the correct answer is option d.



Chapter 5: Number Play

1. A, B, C, D, and E are five distinct whole numbers, with 16 as the smallest number. When arranged in ascending order, the difference between any two consecutive numbers is 8.

- It is given that D is the greatest number and A is the least
- Also, B is greater than E but less than C

Which of the following numbers is definitely divisible by 32?

- a) A b) B c) C d) E

Answer: b

Solution:

Since the numbers are arranged in ascending order with a **constant difference of 8**, and the smallest number is **16**, the five numbers must be: 16, 24, 32, 40, 48

Now, let us assign these values using the given conditions.

- A is the **least**. So, **A = 16**
- D is the **greatest**. So, **D = 48**
- We are told that, **B is greater than E but less than C**

This gives the order: $D > C > B > E > A$

Matching this order with the numbers:

- A = 16
- E = 24
- B = 32
- C = 40
- D = 48

Now, check which number is **definitely divisible by 32**.

Only **32** is divisible by 32, and this value corresponds to **B**.

Hence, option b is the correct answer.

2. A control panel has three bulbs - A, B, and C. Each bulb is associated with one fixed divisor (greater than 3). A bulb glows whenever the entered number is divisible by its own divisor. A technician tested the panel with several numbers and noted which bulbs glowed, as shown in the table below.

Using this information, if 56 is entered, which bulb(s) will glow?

Number entered	Bulbs that glow
12	A,B
16	B
35	C
42	A,C
18	A

- a) A and C b) Only B c) B and C d) A and B

Answer: c

Solution:

From the table:

Bulb C glows for 35 and 42. The common divisor greater than 3 is 7.

So, C glows whenever the input is divisible by 7.

Bulb B glows for 12 and 16. The common divisor greater than 3 is 4.

Hence, B glows whenever the input is divisible by 4.
 Bulb A glows for 12, 18, and 42. The common divisor greater than 3 is 6.
 So, A glows whenever the input is divisible by 6.
 Now check for 56:
 $56 \div 6$ is not an integer. A will not glow
 $56 \div 4 = 14$. B glows
 $56 \div 7 = 8$. C glows
 Therefore, bulbs B and C will glow.
 Option c is correct.

3. Using the digits shown in the Box, form the largest possible 6-digit number that is divisible by 9 (without repeating the digits). In the number formed, which place values contain digits that point to a greater digit than themselves in the box?

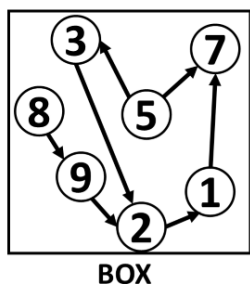

- a) Hundreds and Ones b) Ones and Tens c) Thousands and Tens d) Ones and Thousands

Answer: d

Solution:

We need to form the **largest 6-digit number divisible by 9** using the digits in the BOX. The **divisibility rule of 9** states that the **sum of the digits must be divisible by 9**.

The digits in the BOX are **1, 2, 3, 5, 7, 8, 9**, and their sum is $1 + 2 + 3 + 5 + 7 + 8 + 9 = 35$.

Since we must form a 6-digit number, we remove one digit.

If we remove **8**, the sum becomes $35 - 8 = 27$, which is divisible by 9.

So, the digits used are **1, 2, 3, 5, 7, 9**, and the **largest 6-digit number** formed is **975321**.

Now check the arrows in the BOX:

- **5 points to 7**, so **5** qualifies. In **975321**, **5** is in the **thousands place**.
- **1 points to 7**, so **1** qualifies. In **975321**, **1** is in the **ones place**.

Therefore, the place values that contain a digit that points to a greater number in the BOX are **ones and thousands**.

Hence, option d is correct.

4. Sam has two different two-digit numbers such that:

- Both numbers are divisible by 9
- None of the numbers is a multiple of 18

What is the **LEAST** possible sum of the two numbers?

- a) 45 b) 72 c) 63 d) 54

Answer: b

Solution:

Step 1: List the two-digit multiples of 9

18, 27, 36, 45, 54, 63, 72, 81, 90, 99

Remove multiples of 18:

18, 36, 54, 72, 90

Remaining numbers:

27, 45, 63, 81, 99

Choose the smallest such pair:

27 and 45

$$27 + 45 = 72$$

Hence, option b is the correct answer.

5. The numbers of the SET will be distributed to the Box 1 and Box 2, based on the conditions given below:

- If the number is a multiple of 4 it goes to Box 1
- If the number is a multiple of 6 it goes to Box 2
- If the number is a multiple of both 6 and 4 it goes in both the boxes

Find the ratio of the number of BLACK CIRCLES in Box 1 to the number of WHITE CIRCLES in Box 2, finally.

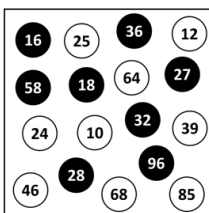

SET

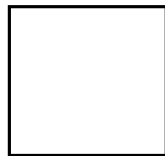

Box 1



Box 2

a) 2:1

b) 3:2

c) 5:2

d) 5:3

Answer: c

Solution:

The numbers that will go into Box 1 are:

BOX 1

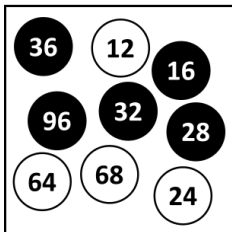

The numbers that will go into Box 2 are:

BOX 2

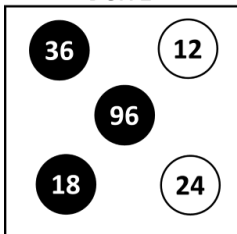

The number of black circles in Box 1 is 5.

The number of white circles in Box 2 is 2.

So, the ratio will be 5:2.

Option c is correct.

6. Ashish and Devika together choose two different numbers from 2 to 24 (both inclusive). The chosen numbers are multiplied, and the product is divided by 25. The remainder decides the result:

- If the remainder is less than 10, Devika wins
- If the remainder is more than 14, Ashish wins
- In all other cases, the game is a draw

What is the minimum possible sum of the numbers chosen by Ashish and Devika such that Ashish wins the game?

- a) 7 b) 8 c) 9 d) 6

Answer: b

Solution:

For Ashish to win, the remainder after dividing the product by 25 must be greater than 14.

So, Ashish wins if the remainder is 15 or more. (minimum possible remainder)

So, if a number leaves a remainder of 15, when divided by 25, it is possible that the number is 15 more than the multiple of 25.

As we need to choose the smallest possible case, let's assume that the multiple is 25 itself.

As $25 + 15 = 40$, when 40 is divided by 25, it leaves a remainder of 15.

Ashish wins in this case.

The product of the numbers chosen = 40

The numbers chosen could be 5 and 8 ($5 \times 8 = 40$)

Hence, the smallest possible sum in this case is $5 + 8 = 13$.

However, let's check if it is also possible for the product to be less than 40 and still the remainder is 15, when divided by 25.

When a smaller number is divided by a larger number, the quotient is 0 and the remainder is the smaller number itself (for example: $6 \div 25$ will give us 0 as quotient and 6 as remainder).

So, the product of the two numbers chosen could be 15 too.

15: $15 \div 25$ leaves remainder 15. So, Ashish wins

To have the product as 15, the numbers chosen must be (1, 15) or (3, 5).

$1 + 15 = 16$ and $3 + 5 = 8$ (which is the minimum possible sum)

Therefore, the LEAST possible sum will be 8. Hence, option b is the correct answer.

7. On the six faces of a die, even numbers from 2 to 12 are written.

- All multiples of 4 are written on adjacent faces such that no two of these faces are opposite to each other
- The sum of the numbers on any two opposite faces is always greater than 10

Which of these pairs are written on opposite faces?

- a) 8 and 10 b) 12 and 6
c) 2 and 12 d) Cannot be determined

Answer: c

Solution:

- All multiples of 4 are written on adjacent faces such that no two of these faces are opposite to each other.

4, 8, and 12 are written on three faces that have a common corner.

- The sum of the numbers on any two opposite faces is always greater than 10.

2 cannot be written opposite to 8 or 4.

Hence, it is opposite to 12.

Similarly, 6 cannot be opposite to 4.
Hence, 6 is opposite to 8 and 10 is opposite to 4.
Thus, the pairs of opposite faces are:

2 and 12

6 and 8

10 and 4

Therefore, option c is the correct answer.

8. In the year 2020, Simran's age was a multiple of 6. In the year 2024, her age was a multiple of 11. Which of the following could possibly be the age of Simran in the year 2024?

a) 11 years

b) 22 years

c) 33 years

d) 44 years

Answer: b

Solution:

Simran's age in 2020 was a multiple of 6.

Her age in 2024 is 4 years more than her age in 2020 and is a multiple of 11.

We check the given options and see which option is a multiple of 6, 4 years ago.

• 11: $11 - 4 = 7$ (not a multiple of 6)

• 22: $22 - 4 = 18$ (a multiple of 6)

• 33: $33 - 4 = 29$ (not a multiple of 6)

• 44: $44 - 4 = 40$ (not a multiple of 6)

Only 22 satisfies both conditions.

So, in the year 2024, Simran's age could be 22.

Hence, the correct answer is option b.

9. The middle number of 5 consecutive even numbers is $5p$. Exactly two numbers in the sequence are divisible by 4, and only one is divisible by 5. Among the following values, which could be the possible value of p .

a) 2

b) 3

c) 4

d) 5

Answer: a

Solution:

The middle number of the sequence is given as $5p$.

Since the numbers are **five consecutive even numbers**, the sequence must be:

$5p - 4, 5p - 2, 5p, 5p + 2, 5p + 4$

Use the condition about divisibility by 5

We are told that **exactly one number** in the sequence is divisible by 5.

• The middle number is $5p$, which is always divisible by 5

• The other four numbers differ from $5p$ by 2 or 4, so they are **not divisible by 5**

So this condition is already satisfied **as long as the middle number is the only multiple of 5**, which is fine for any value of p .

Divisibility by 4:

We are told that **exactly two numbers** in the sequence are divisible by 4.

For this to happen, the **middle number must not be a multiple of 4**.

Instead, it should be **2 more or 2 less than a multiple of 4**.

This way, the numbers **just before and just after** the middle number become multiples of 4.

Trying the options, when $p = 2$: (as $p = 1$ will give us odd numbers)

- Middle number = 10 (which is 2 more than 8)
- The sequence becomes: **6, 8, 10, 12, 14**

Here:

- **8 and 12** are divisible by 4 (exactly two numbers)
- **10** is the only number divisible by 5

All conditions are satisfied. Hence, option a is the correct answer.

10. A cryptarithmic multiplication is shown below. Here, P, Q, M, and N are distinct single-digit natural numbers. MN represents a two-digit number, and PQN represents a three-digit number. What is the smallest possible value of P + M?

$$\begin{array}{r} MN \\ \times 6 \\ \hline PQN \end{array}$$

a) 3

b) 1

c) 4

d) 5

Answer: a

Solution:

The product of 6 and N results in a number with **N in the unit's place**.

This is true for the numbers **0, 2, 4, 6, and 8**:

$$0 \times 6 = 0$$

$$2 \times 6 = 12$$

$$4 \times 6 = 24$$

$$6 \times 6 = 36$$

$$8 \times 6 = 48$$

Since, we have to find the **smallest possible value of P+M**, we start by considering the smallest possible value of **M**, which is **2**. (M cannot be 1, as the highest value of MN in that case will be 18, where $18 \times 6 = 108$. This will have 1 in the hundreds place of the product. This will make $M = P$, which is not possible).

So, let **M = 2**.

If $M = 2$, then the values possible for MN are: 20, 24, 26, and 28 (as 0, 4, 6, and 8 give the same units digit after multiplying by 6)

$$20 \times 6 = 120 \text{ (In this case, } M = Q = 2, \text{ which is invalid.)}$$

$$24 \times 6 = 144 \text{ (In this case, } Q = N = 4, \text{ which is invalid.)}$$

$$26 \times 6 = 156 \text{ (In this case, } \mathbf{P = 1, M = 2, N = 6, \text{ and } Q = 5. \text{ All distinct). Here, we get the smallest possible values for P and M (1 and 2)}$$

$$\begin{array}{r} 26 \\ \times 6 \\ \hline 156 \end{array}$$

$$\text{Similarly, } 28 \times 6 = 168 \text{ (In this case, } \mathbf{P = 1, M = 2, N = 8, \text{ and } Q = 6. \text{ All distinct)}$$

$$\text{Therefore, the smallest possible value of } P + M = 1 + 2 = 3$$

Hence, **option a is correct**.



The Thinking Spot

There are 9 switches in a row on a switchboard. 3 of them belong to lights and the remaining are of fans.

Every two consecutive light switches have exactly two fan switches between them. The switch at the extreme right is NOT a light switch and the switch at the extreme left is NOT a fan switch.

Which of them is definitely a light switch?

- (a) 2nd switch from the left (b) 3rd switch from the left
(c) 6th switch from the right (d) 5th switch from the left

Answer: c

Solution:

There are 9 switches altogether, out of which 3 of them are of lights and 6 are of fans. Also, it is given that every two consecutive light switches (L) have exactly two fan switches (F) between them.

So, there are three possible cases:

Case 1: FLFFLFFLF

Case 2: LFFLFFLFF

Case 3: FFLFFLFFL

However, the question mentions that the switch at the extreme right is not a light switch.

So, case 3 can be eliminated.

Also, the switch at the extreme left is not a fan switch.

Based on this statement, case 1 is also eliminated.

Therefore, the correct sequence of switches is: **LFFLFFLFF**

As we can see, the 6th switch from the right is a light switch.

Thus, option c is the correct answer.



Chapter 6: We Distribute Yet Things Multiply

1. What will come in place of “?”

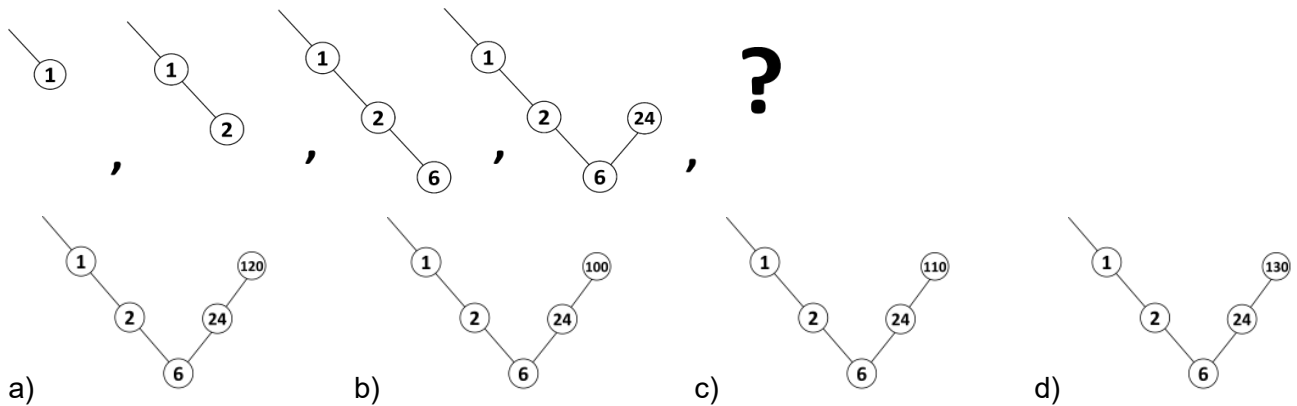

Answer: a

Solution:

Observe the figures carefully. Each new figure adds **one new circle**, and the numbers follow a clear **multiplication pattern**.

Step 1: Observe the numbers

Look at the numbers that appear in order:

- First figure: 1
- Second figure: 2
- Third figure: 6
- Fourth figure: 24

Now notice how each number is formed:

- $1 \times 1 = 1$
- $1 \times 2 = 2$
- $2 \times 3 = 6$
- $6 \times 4 = 24$

So, the rule is: **Each new number is obtained by multiplying the previous number by the next natural number.** (starting from $\times 1$)

Step 2: Find the next number

Following the same pattern:

- $24 \times 5 = 120$

So, the next number must be 120.

Hence, option a is the correct answer.

2. On a weighing scale, both a and b are whole numbers. Which conclusion is logically correct?



- a) The scale can balance only when one of the numbers is 0
- b) The scale can balance for any values of a and b
- c) The scale can balance only when $a = b = 1$
- d) The scale can balance only when a and b are single - digit natural numbers

Answer: a

Solution:

To compare the two sides on the weighing scale, look at:

Left side: $a^2 + b^2$

Right side: $(a + b)^2$

Expand the right side:

$$(a + b)^2 = a^2 + b^2 + 2ab$$

For the scale to balance, both sides must be equal. So, we set them equal:

$$a^2 + b^2 = a^2 + b^2 + 2ab$$

Subtract $a^2 + b^2$ from both sides and we get: $2ab = 0$

This means the product of a and b must be zero.

So, one of the numbers must be 0.

Correct conclusion: One of them has to be zero.

Option a is the correct answer.

3. There are 49 sets of marbles, numbered from 1 to 49. The set numbered k contains k marbles. The marbles in set 49 are sold at ₹1 per marble, those in set 48 at ₹2 per marble, those in set 47 at ₹3 per marble, and so on, with the price per marble increasing accordingly. What is the difference between the maximum and minimum total amount for which a set of marbles can be sold?

- a) $49^2 - 25^2$
- b) $25^2 - 7^2$
- c) $49^2 - 7^2$
- d) $50^2 - 25^2$

Answer: b

Solution:

Each set follows this rule:

- The number of marbles increases as the set number increases.
- Price per marble decreases as the set number increases.

So:

- Small set: few marbles but expensive per marble
- Large set: many marbles but cheap per marble

The total value of a set depends on the balance between these two.

Step 1: Find the maximum value

The value of a set =

$$(\text{number of marbles}) \times (\text{price per marble})$$

For set k :

- Marbles = k
- Price per marble = $50 - k$

So, value = $k \times (50 - k)$ [These are in the form of two factors of a number]
This value is the highest when the two factors are as close to each other as possible.

Closest pair:

- $k = 25$
- $50 - 25 = 25$

So,

- Maximum value of a set = $25 \times 25 = 625$

Step 2: Find the minimum value

The smallest value will occur at the extreme ends:

- Set 1: 1 marble \times ₹49 = 49
- Set 49: 49 marbles \times ₹1 = 49

So,

- Minimum value = 49

Step 3: Find the required difference

Difference = Maximum - Minimum = $625 - 49 = 576$

Step 4: Express as a difference of squares

$$576 = 25^2 - 7^2$$

Option b is the correct choice.

4. A merchant has $(19^2 - 1)$ coins. He must distribute the coins to some children.

The number of children is equal to the number of distinct prime factors of 30

- First, each child receives 4 packs of 6 coins each
- Then, after this distribution, the merchant must give each child 3 more packs of 6 coins each, ONLY IF the remaining coins are more than half of the original count

Which of the following expressions represents the number of coins finally left with the merchant, after the distribution(s)?

a) $(19^2 - 1) - 3(6 \times 4)$

b) $(19^2 - 1) - 3(6 \times 4 + 3 \times 6)$

c) $(19^2 - 1) - 3(6 \times 4 - 3(3 \times 6))$

d) $(19^2 - 1) - 5(6 \times 4 + 3 \times 6)$

Answer: b

Solution:

Total coins = $19^2 - 1 = 360$

Number of children = distinct prime factors of 30 = 2, 3, 5 (3 children)

Each child first receives 4 packs of 6 coins each. $4 \times 6 = 24$ coins.

So, total coins distributed = $3 \times 24 = 72$.

Half of 360 = $360/2 = 180$. So, the merchant must give each child 3 more packs of 6 coins each, ONLY IF the remaining coins are more than 180 (more than half of the original count).

Remaining coins = $360 - 72 = 288$, which is more than half of 360.

So, extra packs must be given.

Each child will again get 3 more packs of 6 coins each: $3 \times 6 = 18$.

Extra total distribution = $3 \times 18 = 54$.

Thus, the expression for the remaining coins is:

Total coins - (First distribution + Second Distribution)

$$= (19^2 - 1) - [(3 \times 4 \times 6) + (3 \times 3 \times 6)]$$

$$= (19^2 - 1) - [3 \times (4 \times 6) + 3 \times (3 \times 6)]$$

$$= (19^2 - 1) - 3 \times (6 \times 4) + (3 \times 6)$$

Hence, option b is the correct answer.

5. A two-digit number XY is formed using two different digits. When the sum of its digits is added to the number, a new number is formed, which is divisible by 3. Which of the following will be **DEFINITELY** true about the new number?

- a) X is a multiple of 3
b) Y is a multiple of 3
c) $X + Y$ is a multiple of 3
d) None of these

Answer: c

Solution:

Step 1: Represent the number

Since X is in the tens place and Y is in the ones place, the number is:

$$\text{Number} = 10X + Y$$

Step 2: Add the sum of digits

$$(10X + Y) + (X + Y) = 11X + 2Y$$

Step 3: Simplify the expression

$$11X + 2Y = 9X + 2X + 2Y = 9X + 2(X + Y)$$

We are told that $9X + 2(X + Y)$ is a multiple of 3 (the new number is divisible by 3)

We know that $9X$ is anyways divisible by 3. So, the divisibility depends only on $2(X + Y)$.

As 2 is not a multiple of 3, for $2(X + Y)$ to be a multiple of 3, only $(X + Y)$ must be divisible by 3.

This means the new number is divisible by 3 only when $(X + Y)$ is a multiple of 3.

Thus, option c is the correct choice.

6. A , B , and C are three different digits among 1 - 9. How many digits **CANNOT** be assigned to " A " if the following condition is true?

$$A + B \times C = 25$$

- a) 3
b) 4
c) 5
d) 6

Answer: c

Solution:

We are given the equation

$$A + (B \times C) = 25, \text{ where } A, B, \text{ and } C \text{ are distinct digits from 1 to 9.}$$

Step 1: Fix the possible range of $B \times C$

If $A = 1$, then

$$B \times C = 25 - 1 = 24 \text{ (maximum possible value)}$$

If $A = 9$, then

$$B \times C = 25 - 9 = 16 \text{ (minimum possible value)}$$

So, the product $B \times C$ must be one of the values:

16, 17, 18, 19, 20, 21, 22, 23, 24

Step 2: Eliminate impossible products

Among these:

- **17, 19, and 23** are prime numbers and **cannot** be written as the product of two digits.
- **22** can only be written as 1×22 or 2×11 , which are not valid since digits must be from 1 to 9.

So, $B \times C$ **cannot** be **17, 19, 22, or 23**.

This immediately rules out:

- $A = 25 - 17 = 8$
- $A = 25 - 19 = 6$
- $A = 25 - 22 = 3$
- $A = 25 - 23 = 2$

Thus, **A cannot be 2, 3, 6, or 8.**

Step 3: Check the remaining possible values of A

Remaining values to check: **1, 4, 5, 7, 9**

- **A = 1:** $B \times C = 24$
Possible as 3×8 or 4×6 , valid.
- **A = 4:** $B \times C = 21$
Possible as 3×7 , valid.
- **A = 5:** $B \times C = 20$
Possible as 4×5 , but digit 5 repeats, not allowed.
A = 5 is invalid
- **A = 7:** $B \times C = 18$
Possible as 2×9 or 3×6 , valid.
- **A = 9:** $B \times C = 16$
Possible as 2×8 , valid.

Step 4: Final Conclusion

Values that **A cannot take** are:

2, 3, 5, 6, and 8

That is **5 values**. Hence, option c is the correct answer.

7. What will come in place of “?”

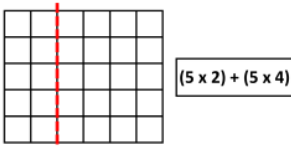
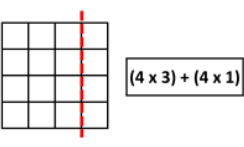
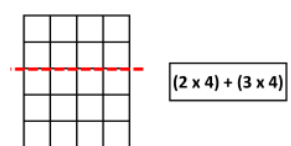
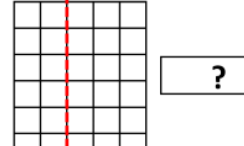
- a) $(2 \times 4) + (2 \times 6)$ b) $(6 \times 3) + (6 \times 4)$ c) $(1 \times 6) + (1 \times 4)$ d) $(6 \times 2) + (6 \times 3)$

Answer: d

Solution:

The big grid is divided into two parts by the red dotted line.
We count the number of squares in each part and add them.
Understanding the pattern (from the terms)

Term 1:

In the first grid, the rectangle has 5 rows.

The red line divides the grid into two parts:

Left-side part: 5 rows and 2 columns

Number of squares = 5×2

Right-side part: 5 rows and 4 columns

Number of squares = 5×4

So, the total squares are written as $(5 \times 2) + (5 \times 4)$

Now look at the question grid

The grid has 6 rows.

The red dotted line divides the grid into:

First part: 6 rows and 2 columns = 6×2

Second part: 6 rows and 3 columns = 6×3

So, the expression that represents the grid is $(6 \times 2) + (6 \times 3)$

Therefore, the correct answer is option d.

8. **A team of three painters - A, B, and C - must paint rooms and each painter paints 3 rooms per working day. They are scheduled to work for 50 days starting Monday.**

- **Painter A does not work on weekends (no Saturdays or Sundays)**
- **Painter B does not work on every 5th day (Day 5, Day 10, Day 15, and so on)**
- **Painter C works on all 50 days**

Based on the above rules, determine an expression that represents the total number of rooms painted by all three painters combined.

- a) 3×50 b) $3 \times (3 \times 50)$ c) $3 \times (36 + 40 + 50)$ d) $3 \times 3 \times (36 + 40 + 50)$

Answer: c

Solution:

Step 1: Determine how many days each painter works

A's schedule:

Works only on weekdays.

In 7 days, work 5 days.

In 50 days, there are 7 full weeks and 1 extra day (Monday).

A Works = $7 \times 5 + 1 = 36$ days

B's schedule:

Absent every 5th day.

Total multiples of 5 up to 50 = $50 \div 5 = 10$ days off.

B Works = $50 - 10 = 40$ days

C's schedule:

C Works every day = 50 days

Each one of them paints 3 rooms per working day.

So, the total number of rooms painted = $3 \times (36 + 40 + 50)$

Option c is the correct answer.

9. **A train runs from A to D via B and C. The number of passengers entering and leaving at each station is given in the table. Each passenger buys a separate ticket for each segment travelled (A→B, B→C, C→D).**

Ticket prices are:

A→B = Rs. 1, B→C = Rs. 2, C→D = Rs. 1

Which of the following is the total cost of all tickets purchased?

Stations	In	Out
A	150	-
B	60	80
C	70	50
D	-	150

- a) Rs. $[(150 \times 1) + (70 \times 3) + (60 \times 2) + (80 \times 1)]$ b) Rs. $[(150 \times 1) + (70 \times 2) + (60 \times 1) + (80 \times 1)]$
c) Rs. $[(150 \times 1) + (70 \times 1) + (60 \times 2) + (80 \times 1)]$ d) Rs. $[(150 \times 1) + (70 \times 3) + (60 \times 1) + (80 \times 1)]$

Answer: a

Solution:

We calculate the cost for each group separately.

From A → B (Rs. 1 per ticket):

150 passengers travel

Cost = $150 \times \text{Rs. } 1$

At B, 80 passengers leave, remaining = 70

From B → C (Rs. 2 per ticket):

70 passengers (from A) travel, cost = $70 \times \text{Rs. } 2$

60 new passengers enter at B, cost = $60 \times \text{Rs. } 2$

From C → D (Rs. 1 per ticket):

At C, 50 passengers leave, remaining = 80

80 passengers travel, cost = $80 \times \text{Rs. } 1$

70 new passengers enter at C, cost = $70 \times \text{Rs. } 1$

Total Cost Expression:

Rs. $[(150 \times \text{Rs. } 1) + (70 \times \text{Rs. } 2) + (60 \times \text{Rs. } 2) + (80 \times \text{Rs. } 1) + (70 \times \text{Rs. } 1)]$

= Rs. $[(150 \times \text{Rs. } 1) + 70 \times (\text{Rs. } 2 + \text{Rs. } 1) + (60 \times \text{Rs. } 2) + (80 \times \text{Rs. } 1)]$

Simplifying:

Rs. $[(150 \times \text{Rs. } 1) + (70 \times \text{Rs. } 3) + (60 \times \text{Rs. } 2) + (80 \times \text{Rs. } 1)]$

Hence, option a is correct.

10. If $2(pq + rs)$ is coded as PQ_2_RS, $3(kl + mn)$ is coded as KL_3_MN and $4(gh + ij)$ is coded as GH_4_IJ, what will be the possible code of the SIMPLIFIED FORM of the following expression?

$(a + b)(c + d) - (a - b)(c - d)$

a) AC_2_BD

b) AD_3_BC

c) AB_2_CD

d) AD_2_BC

Answer: d

Solution:

Start with the expression:

$(a + b)(c + d) - (a - b)(c - d)$

Expand both parts:

$(a + b)(c + d)$ becomes: $ac + ad + bc + bd$

$(a - b)(c - d)$ becomes: $ac - ad - bc + bd$

Subtract the second from the first:

$(ac + ad + bc + bd) - (ac - ad - bc + bd)$

Change the signs of the second bracket and combine:

$ac + ad + bc + bd - ac + ad + bc - bd$

ac cancels with ac and bd cancels with bd, leaving:

$2ad + 2bc$

Factor out 2:

$2(ad + bc)$

We are given that $2(pq + rs)$ is coded as PQ_2_RS, $3(kl + mn)$ is coded as KL_3_MN.

The digit outside the brackets appears in the middle of the code, with underscores on either side. The letters are changed to UPPERCASE and written in the same order, without the "+" sign.

Based on this rule, $2(ad + bc)$ must be written as AD_2_BC.

Option d is the correct answer.



The Thinking Spot

Two coins are hidden in the grid below in two different rows and columns. If the following statements are true:

- None of the coins is in A's column, but one is in its row
- None of the coins is in B's row, but one is in its column
- None of the coins is in C's row, but one is in its column

Which of the following blocks CANNOT have a coin?

A			
		C	
	B		

a)

b)

c)

d)

Answer: c

Solution:

Given that all the statements are true.

As per the first statement, A's row has one coin and A's column has none of the coins. So, we cancel out the possibilities of coins in A's column.

A			
x		C	
x			
x	B		

Similarly, as per the next two statements, there are no coins in B's row and C's row. So, we cancel out these possibilities of position of coins.

A			
x	x	C	x
x			
x	B	x	x

Now, there are 6 possible positions where 2 coins can be hidden.

As per the given conditions, one coin is in A's row.

- If one coin is placed in 1st cell as shown below, then it also satisfies B's condition of having 1 coin in its column.
- Then the 2nd coin must be placed in C's column as shown below.

A	1		
x	x	C	x
x			
x	B	x	x

,

A	1		
x	x	C	x
x		2	
x	B	x	x

- If one coin is placed in 2nd cell as shown below, then it also satisfies C's condition of having 1 coin in its column.
- Then the 2nd coin must be placed in B's column as shown below.

A		1	
x	x	C	x
x			
x	B	x	x

,

A		1	
x	x	C	x
x	2		
x	B	x	x

- If one coin is placed in 3rd cell as shown below, then the 2nd coin cannot be placed in any other cell because it does not satisfy B's and C's condition together in either of the arrangement.

A			1
x	x	C	x
x	2		
x	B	x	x

or

A			1
x	x	C	x
x		2	
x	B	x	x

Hence, the coin cannot be placed in the 3rd cell of 1st row as it contradicts the given conditions. Hence, option c is the answer.



Chapter 7: Proportional Reasoning

1. A fruit basket has different fruits, Bananas, Apples, Cherries, and Strawberries.

- The bananas are $\frac{1}{3}$ the number of cherries and twice that of apples
- The strawberries are 4 more than the number of apples
- The number of fruits of each variety are all even numbers less than 15

Based on the above statement, fill in the blank with the appropriate fruit name. For every 3 strawberries, there are proportionately 6 _____.

- a) Bananas b) Apples c) Cherries d) All of the above

Answer: c

Solution:

Let A = Apples, B = Bananas, C = Cherries, and S = Strawberries.

The bananas are $\frac{1}{3}$ the number of cherries and twice the number of apples.

$$B = \left(\frac{1}{3}\right)C \text{ and } B = 2A$$

$$2A = \left(\frac{1}{3}\right)C$$

$$A = \left(\frac{1}{6}\right)C$$

So, the apples are one-sixth of the number of cherries.

The number of cherries is a multiple of 6. (6, 12, 18,)

However, as the number of fruits of each variety is an even number less than 15, the number of cherries is either 6 or 12.

Case 1: C = 6

If C = 6, then B = 2 and A = 1.

Then, as per statement 2, S = A + 4 = 1 + 4 = 5

Here, as A = 1 and S = 5, this case is invalid, as the number of fruits of each variety is an even number.

Case 2: C = 12

If C = 12, then B = 4, A = 2.

Then, S = 2 + 4 = 6.

This case is valid.

Therefore, in the first fruit basket, there are 4 bananas, 2 apples, 12 cherries, and 6 strawberries. The given statement is: "For every 3 strawberries, there are proportionately 6 _____."

As there are 6 strawberries and the statement says "For every 3 strawberries", the number of strawberries is halved to 3.

For 3 strawberries, proportional amounts of other fruits are:

- Apples: $3 \times \left(\frac{2}{6}\right) = 1$
- Bananas: $3 \times \left(\frac{4}{6}\right) = 2$
- Cherries: $3 \times \left(\frac{12}{6}\right) = 6$

Only one fruit matches the exact number mentioned in the sentence.

Hence, for every 3 strawberries, there are proportionately 6 CHERRIES.

Option c is correct.

2. There are two unknown proportional ratios, A : B and C : D, where A, B, C, and D are DIFFERENT single-digit numbers.

- A is 2 less than C
- D is 3 times B

What is the HIGHEST difference between any two values among A, B, C, and D?

- a) 2 b) 3 c) 4 d) 5

Answer: d

Solution:

Given that A : B and C : D are proportional ratios.

A:B = C:D (meaning $A/B = C/D$). Also, $A = C - 2$ and $D = 3B$

Substituting $A = C - 2$ gives:

$$(C - 2)/B = C/3B$$

$$(C - 2) \times 3B = B \times C$$

$$(C - 2) \times 3 = C$$

$$3C - 6 = C$$

$$2C = 6$$

$$C = 3.$$

$$A = C - 2$$

$$\text{Hence, } A = 3 - 2 = 1.$$

$$A/B = C/D,$$

$$1/B = 3/D$$

Now, we have to find possible values of B and D that fit all the given conditions.

$$D = 3B.$$

As D is also a single digit, D can either be 3, 6 or 9

B can either be 1, 2 or 3.

But, as $A = 1$ and $C = 3$, B cannot be 1 or 3.

So, $B = 2$.

$$D = 3 \times 2 = 6.$$

Hence, the ratios are: $1 : 2 :: 3 : 6$.

The highest possible difference between any two values among them:

$$6 - 1 = 5.$$

Option d is correct.

-
3. **A mixture contains milk and water. When 15 litres of water is added to it, the total quantity of the mixture becomes 120 litres, where the quantity of milk and water have the LEAST POSSIBLE DIFFERENCE between them. Now, an additional 35 litres of mixture having the same milk-to-water ratio as the original mixture is added to this new mixture. What will be the ratio of milk to water in the final mixture?**

a) 1:1

b) 5:6

c) 15:16

d) 16:15

Answer: d

Solution:

Let the initial quantity of milk = M litres and water = W litres.

When 15 litres of water is added,

the total quantity becomes:

$$M + (W + 15) = 120$$

$$M + W = 105 \dots \text{(Equation 1)}$$

Also, the goal is to have the least possible difference between the quantity of milk and water after adding the 15 liters of water.

Logically, we know that the least possible difference between any two quantities will be 0.

Both quantities are EQUAL.

$$\text{So, } M = W + 15 \dots \text{(Equation 2)}$$

Step 1: Solving for M and W

From (1) and (2):

Substitute $M = W + 15$ into (1):

$$(W + 15) + W = 105$$

$$2W + 15 = 105$$

$$2W = 90$$

$$W = 45 \text{ litres}$$

Then from (2):

$$M = 45 + 15 = 60 \text{ litres}$$

So, initially,

$$\text{Milk : Water} = 60 : 45 = 4 : 3$$

Step 2: Composition after adding 15 litres of water

After adding 15 litres of water:

- Milk = 60 litres

- Water = $45 + 15 = 60$ litres

$$\text{Ratio} = 1 : 1$$

(Total mixture = 120 litres)

Step 3: Now, 35 litres of the original mixture (with ratio 4 : 3) is added

From the ratio 4 : 3,

Total parts = 7.

So, in 35 litres of original mixture:

- Milk = $(4/7) \times 35 = 20$ litres

- Water = $(3/7) \times 35 = 15$ litres

Step 4: Adding this to the current mixture

New totals:

- Milk = $60 + 20 = 80$ litres

- Water = $60 + 15 = 75$ litres

$$\text{Ratio of milk to water} = 80 : 75 = 16 : 15$$

Therefore, option d is correct.

4. Six friends A, B, C, D, E, and F are standing in a straight line positioning from 1 to 6 (from left to right).

- The positions of A and C are in 1 : 2 ratio

- E is at an extreme end and F is at an odd numbered position

- B is next to D

- The positional ratios of D to E are in proportion to C to B

What is the position of F?

a) 1

b) 3

c) 5

d) Cannot be determined

Answer: c

Solution:

The positions of A and C are in 1 : 2 ratio

So, there are 3 possible cases:

Case I A C
 1 2 3 4 5 6

Case II A C
 1 2 3 4 5 6

Case III A C
 1 2 3 4 5 6

E is at an extreme end and F is at an odd numbered position

Fill in the definite positions, as shown below:

Case I A C E
 1 2 3 4 5 6

Case II A C
 1 2 3 4 5 6

Case III E A F C
 1 2 3 4 5 6

B is next to D

By this, we can eliminate case III, as B and D cannot be next to each other.

The remaining possible cases are:

Case I A C B/D B/D E
 1 2 3 4 5 6

Case II E A F C B/D B/D
 1 2 3 4 5 6

The positional ratios of D to E are in proportion to C to B

$$D : E = C : B$$

$$D/E = C/B$$

In case II, this relationship is not possible, as C/B value is either 4/5 or 4/6 (less than 1), while D/E value is either 5/1 or 6/1 (greater than 1). So, this case is eliminated.

Hence, the possible positions in case I are:

Case I A C B/D B/D E
 1 2 3 4 5 6

Here, if B is in 3 and D is in 4, then C/B is 2/3, and D/E is 4/6. So, they are proportional.

Else, if B is in 4 and D is in 3, then C/B = 2/4, and D/E = 3/6. Again, they are proportional.

In any case, we can see that position 5 is empty. Hence, we get F at position 5.

Therefore, option c is correct.

5. In the image given below, the ratio of blue stars to red stars is 1 : 2. Similarly, answer the following question based on the image.

What should replace the question mark so that the ratios are in proportion?

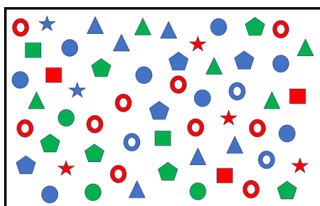

$$\text{Red Square} : \text{Blue Triangle} :: ?$$



a)

b)

c)

d)

Answer: c

Solution:

The count of is 3 and the count of is 6.

So, the ratio given in the question is 3 : 6 i.e., 1 : 2.

Let's check the options to find the ratio which is in proportion to 1 : 2.



Option a: is 5 : 4



Option b: is 4 : 3



Option c: is 5 : 10 i.e., 1 : 2



Option d: is 4 : 3

Therefore, option c is correct.

6. Find the ratio of unshaded (white) rectangles to ONLY PARTIALLY shaded (grey + white) rectangles in the figure given below.

Note: Please count all squares as rectangles for the purpose of this question

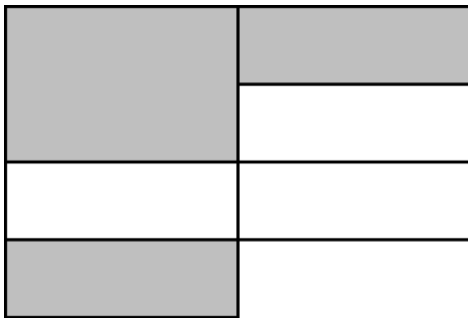

a) 1 : 2

b) 5 : 6

c) 5 : 7

d) 4 : 7

Answer: c

Solution:

Completely unshaded rectangles:

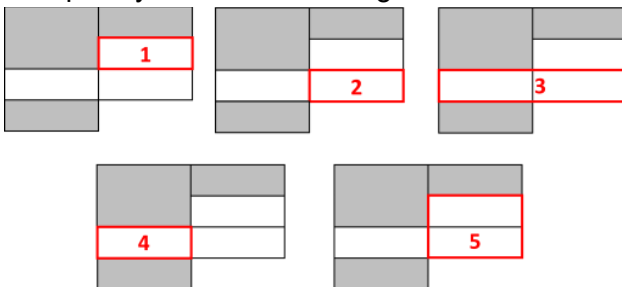

There are 5 completely unshaded rectangles.

Partially shaded rectangles:

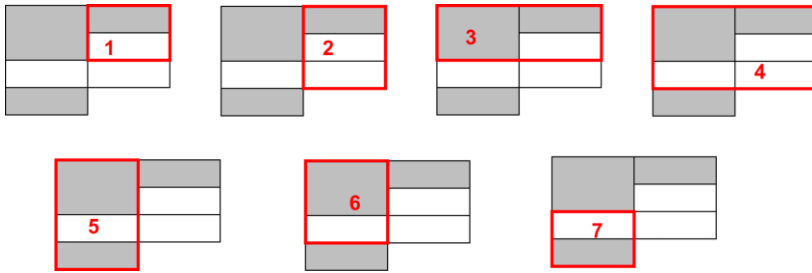

There are 7 partially shaded rectangles.

Hence, the ratio of completely unshaded to partially shaded rectangles is 5 : 7.

Therefore, option c is correct.

7. Three children have ages in the ratio 2 : 3 : 4. Each receives pocket money equal to Rs. 5 less than their age, and together they have Rs. 30.

How much minimum extra money should be added so that their final amounts are in the same ratio as their ages?

a) Rs. 4

b) Rs. 6

c) Rs. 8

d) Rs. 12

Answer: b

Solution:

Let the children's ages be in the ratio 2 : 3 : 4.

So, let their ages be $2k$, $3k$, and $4k$.

Each child has money which is 5 less than their age.

Hence, their current amounts are $(2k - 5)$, $(3k - 5)$, and $(4k - 5)$.

According to the question, their total money is Rs. 30.

So,

$$(2k - 5) + (3k - 5) + (4k - 5) = 30$$

$$9k - 15 = 30$$

$$9k = 45$$

$$k = 5$$

Therefore, the ages of the children are 10, 15, and 20 years.

Their current amounts are:

$$10 - 5 = \text{Rs. } 5, \quad 15 - 5 = \text{Rs. } 10, \quad \text{and} \quad 20 - 5 = \text{Rs. } 15.$$

Now, the new amounts are to be proportional to their ages $(10 : 15 : 20) = (2 : 3 : 4)$.

So, let the new amounts be $2g$, $3g$, and $4g$.

Each new amount must be greater than the current amount.

Hence,

$$2g \geq 5, \quad 3g \geq 10, \quad \text{and} \quad 4g \geq 15$$

$$g \geq 2.5, \quad g \geq 3.33, \quad g \geq 3.75$$

$$\text{Minimum possible } g = 3.75$$

To make the amounts whole numbers, take $g = 4$.

Then, new amounts are 8, 12, and 16.

Increase in money:

$$\text{First child: } 8 - 5 = 3$$

$$\text{Second child: } 12 - 10 = 2$$

$$\text{Third child: } 16 - 15 = 1$$

$$\text{Total extra money required} = 3 + 2 + 1 = \text{Rs. } 6$$

Option b is correct.

8. In a digital clock of HH : MM format, how many times the time will be as such the HH : MM ratio will be in proportion to 1 : y where y is a single digit number?
(Here, the clock is in 12 hour format, where HH : MM will be 00-12 : 00-59)

- a) 49 b) 89 c) 81 d) 101

Answer: b

Solution:

We need $HH : MM = 1 : y$

So, $MM = y \times HH$, where $y = 1$ to 9 .

HH ranges from 1 to 12 only (12 hour format)

Condition for a valid time:

The minute value in a clock cannot exceed 59.

So, whatever value we get for MM, it must be at most 59.

Since, $MM = y \times HH$, we get, $y \times HH \leq 59$

To find the possible values of y, divide both sides by HH:

$$y \leq 59 / HH$$

This means, for a fixed hour, y can only go up to $59 \div HH$ (and must be a whole number).

For each hour, number of valid y values = $\min(9, [59/HH])$

HH (h)	[59/h]	Maximum y allowed	Number of valid y values
1	59	9	9
2	29	9	9
3	19	9	9
4	14	9	9
5	11	9	9
6	9	9	9
7	8	8	8
8	7	7	7
9	6	6	6
10	5	5	5
11	5	5	5
12	4	4	4

Count for each hour is 9, 9, 9, 9, 9, 9, 8, 7, 6, 5, 5, 4.

Total: $9 + 9 + 9 + 9 + 9 + 9 + 8 + 7 + 6 + 5 + 5 + 4 = 89$

Hence, option b is the correct answer.

9. A fruit seller sells apples and mangoes to 10 customers:

- The price per dozen of apples and mangoes is in the ratio 3 : 5
- Each customer buys a pack in which the number of apples and mangoes is in the ratio 1 : 3, and both quantities are multiples of 4
- The price of each fruit is a whole number greater than 10

If the total amount collected from all the customers is ₹8064, what is the MAXIMUM possible number of packs sold to a customer?

- a) 24 b) 18 c) 21 d) 19

Answer: d

Solution:

Let the price per dozen apples be **3k** and the price per dozen mangoes be **5k**.

So,

$$\text{Price per apple} = 3k \div 12 = k \div 4$$

$$\text{Price per mango} = 5k \div 12$$

$k \div 4$ is > 10 and $5k \div 12$ is greater than 10.

To satisfy the above conditions, k must be a number that is divisible by both 4 and 12.

The least possible value of k is 48.

$$\text{Hence, the minimum cost of apple} = 48/4 = ₹12$$

$$\text{The minimum cost of mango} = (5 \times 48)/12 = ₹20$$

Each pack of fruits contains apples and mangoes in the ratio **1 : 3**.

Also, the number of each type of fruit must be a **multiple of 4**.

Therefore, possible packs are:

- 4 apples and 12 mangoes
- 8 apples and 24 mangoes
- 12 apples and 36 mangoes, and so on.

To **maximize the number of fruits sold to a single customer**, we must **minimize the number of fruits sold to the other customers**.

Hence, the smallest possible pack is **4 apples and 12 mangoes**.

The least possible number of fruits for one pack = 16.

Cost of one such pack:

$$4 \times 12 + 12 \times 20 = 48 + 240 = 288$$

Given that the amount from all the customers is **₹8064**:

$$n \times 288 = 8064 \text{ (where } n \text{ is the number of packs sold to all the customers)}$$

$$n = 8064/288 = 28.$$

Hence, the maximum possible number of packs sold altogether = 28.

Out of this, to maximise the count for one customer, assume that all other 9 bought one pack each.

So, the maximum number of packs bought by a customer will be $28 - 9 = 19$

Option d is the correct answer.

10. What will come in place of "?"

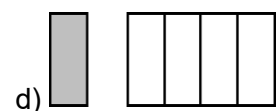
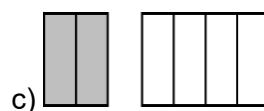
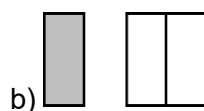
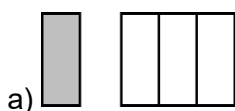
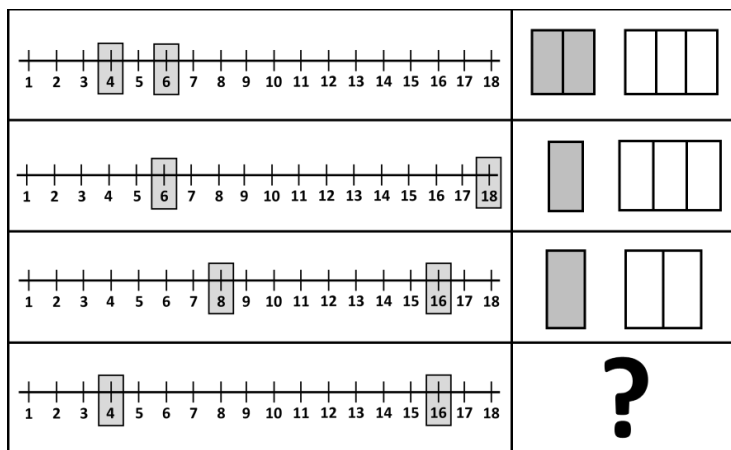

Answer: d

Solution:

In each row, the two shaded numbers on the number line form a fraction. The fraction is simplified.

Then, on the right, the numerator is represented by shaded blocks and the denominator is represented by the white blocks.

For example, if 4 and 6 are shaded, we write $\frac{4}{6}$ and simplify it to $\frac{2}{3}$.
That is why there are 2 shaded blocks and 3 white blocks on the right side.
In the question row, the shaded numbers are 4 and 16.
So, the fraction is:
 $\frac{4}{16}$
Now simplify it by dividing both numbers by 4:
 $\frac{4}{16} = \frac{1}{4}$
So, we need 1 shaded block and 4 white blocks.
That matches option d.
Hence, the correct answer is option d.



Sam arranged the following 4 blocks vertically, one on top of another, such that

- There are at least 2 blocks below the block having a circle
 - The block with a triangle has at least 1 block above it
 - The block having a rectangle is immediately above the block having a star
- How many different arrangements satisfy all the above conditions?



(a) 0

(b) 1

(c) 2

(d) 3

Answer: c

Solution:

The block having a rectangle is immediately above the block having a star.

Also, the block with a triangle has at least one block above it. So, the block with the triangle cannot be the topmost block.

There are at least 2 blocks below the block having a circle. So, the block with the circle can only be in the top 2 positions.

Hence, the following are the possible combinations. The correct answer is option c.



Case 1



Case 2



PART 2
ARTIFICIAL INTELLIGENCE

Chapter 1: AI Project Lifecycle

Exercise

A. Multiple Choice Questions.

1. AI learns from:
a) Magic
b) Luck
c) Data
d) Guessing
2. In spam detection, the AI problem is to:
a) Send emails
b) Write emails
c) Delete all emails
d) Identify spam emails
3. The first stage of a project cycle is:
a) Defining the problem
b) Data collection
c) Model development
d) Model deployment
4. If AI model predicts 8 out of 10 spam emails, the accuracy of model:
a) 50%
b) 20%
c) 80%
d) 100%
5. AI model improves because:
a) It thinks like human
b) It has feeling
c) It gets new data added
d) It gets angry

B. Fill in the blanks.

1. AI learns by finding _____ in data.
2. An AI project follows a _____ cycle.
3. Spam emails often contain suspicious _____.
4. After testing, we _____ the system.
5. AI cannot work without _____.

C. Short answer questions.

1. How does AI learn?
2. Why is defining the problem important in an AI project?
3. What happens in the testing stage of an AI project?
4. What is meant by accuracy in AI?
5. Give one real-life example of an AI project.

D. Think and apply.

1. Imagine you are building an AI system to detect fake news.

Fill the table:

Stage	Your Answer
Define the problem	_____
Collect data	_____
Test AI tools	_____
Reflect and improve	_____

2. An online shopping company wants to build an AI system to predict whether a product will be delivered **on time or late**.

To build this system, the company collects the following data from previous orders:

Order	Distance	Weather	Traffic	Delivery Partner	Final Status
O1	5 km	Clear	Low	Experienced	On Time
O2	20 km	Rainy	High	New	Late
O3	10 km	Clear	Low	Experienced	On Time
O4	15 km	Rainy	High	New	Late

After training, the model learned from the following pattern and delivery will be on time, if:

- Distance is less than 10 km.
- Weather is Clear
- Traffic is Low
- Delivery partner is Experienced

Based on the learned pattern, complete the following table.

Order	Distance	Weather	Traffic	Delivery Partner	Final Status
O5	8 km	Clear	Low	Experienced	_____
O6	18 km	Rainy	High	New	_____

Solutions

A. Multiple Choice Questions.

1. c) Data
2. d) Identify spam emails
3. a) Defining the problem
4. c) 80%
5. New data is added

B. Fill in the blanks.

1. patterns
2. project
3. words
4. improve
5. data

C. Short answer questions.

1. AI learns by analysing data and finding patterns to make predictions.
2. It helps understand what the AI system needs to solve and guides data collection.
3. The AI model is checked using test data to measure accuracy and performance.
4. Accuracy is how correctly the AI predicts results.
Example: 8 correct out of 10 = 80% accuracy.
5. Spam email detection system.

D. Think and apply.

1. Imagine you are building an AI system to detect fake news.

2. Fill the table:

Stage	Your Answer
Define the problem	Detect fake news articles
Collect data	Collect real and fake news examples
Test AI tools	Check if AI correctly identifies fake news
Reflect and improve	Add more data and improve accuracy

3.

Order	Distance	Weather	Traffic	Delivery Partner	Final Status
O5	8 km	Clear	Low	Experienced	On Time
O6	18 km	Rainy	High	New	Late

Chapter 2: Artificial Intelligence and Its Applications

Exercise

A. Multiple Choice Questions.

- AI helps in environmental protection by:
 - Tracking wildlife populations
 - Detecting plastic waste
 - Predicting pollution levels
 - All of the above
- No-code AI tools allow users to:
 - Program AI models using coding
 - Only analyse text data
 - Train AI models without coding
 - Replace teachers completely
- AI can predict future health risks by analysing a patient:
 - Favourite movies
 - Social media posts
 - Medical history and lifestyle habits
 - Travel destinations
- Which environmental problem can AI help solve by analysing satellite images of rivers and oceans?
 - Soil degradation
 - Air pollution
 - Plastic pollution
 - Water shortage
- An example of AI in smart homes is:
 - Self-driving cars
 - Tracking wildlife populations
 - Voice-controlled appliances
 - Predicting diseases

B. Fill in the Blanks

- AI-powered _____ can answer health questions and remind patients to take medicines.
- Satellites and sensors help AI detect _____ pollution in oceans and rivers.
- AI in education can provide _____ learning tailored to each student's needs.
- Wearable devices allow AI to perform _____ patient monitoring.
- Platforms like _____ allow students to train AI models without coding.

C. Short Answer Questions

- Name two ways AI helps in reducing environmental problems.
- How does AI assist doctors in medical diagnosis?
- Give one example of AI application in smart homes.
- What is the benefit of personalised learning in education?
- Explain the role of AI in agriculture.

D. Think and Apply

- Design a simple AI project using a no-code platform to help sort waste in your school. What steps would you follow?
- How can AI predict and prevent water shortages in your area?
- Suggest a way AI could help students struggling with mathematics.
- If you were a farmer, how would you use AI to improve crop production and protect soil health?

Solutions

A. Multiple Choice Questions.

1. d) All of the above
2. b) Train AI models without coding
3. b) Medical history and lifestyle habits
4. b) Plastic pollution
5. b) Voice-controlled appliances

B. Fill in the Blanks

1. chatbots
2. plastic
3. personalized
4. continuous
5. Teachable Machine

C. Short Answer Questions

1. Name two ways AI helps in reducing environmental problems:
 - Detecting plastic waste in oceans
 - Monitoring wildlife populations
2. AI analyses medical images, patient history, and symptoms to detect diseases early.
3. Voice-controlled lights or smart assistants that control appliances.
4. Students learn at their own pace based on their strengths and weaknesses.
5. AI helps farmers predict weather, monitor crops, detect diseases, and improve yield.

D. Think and Apply

1. Steps:
 - Define problem: Sort recyclable and non-recyclable waste
 - Collect data: Images of different waste items
 - Train model using no-code tool
 - Test model with new waste images
 - Improve by adding more data
2. AI analyses rainfall data, water usage, and weather patterns to predict shortages and suggest saving measures.
3. AI tutor can give step-by-step solutions and personalised practice questions.
4. AI can:
 - Predict weather
 - Suggest best crops
 - Monitor soil moisture
 - Detect plant diseases





Chapter 3: Data and Fairness in AI



Exercise

A. Think and Apply

1. For the dog training dataset, record the following:
 - How many images are included?
 - How are the images similar?
 - How are the images different?
2. For the cat training dataset, record the following:
 - How many images are included?
 - How are the images similar?
 - How are the images different?



Once your classifier is finished, test your dataset with the images below. Fill in the table on the next page about your testing dataset:





Image	Classification	Confidence Score	Correct?
			
			
			
			
			

1. Which class did your classifier work better on? Why do you think that is?
 - a. Cats
 - b. Dogs
2. With your group, use the photos on the tables to re-curate your training dataset. Record the following:
 - a. For the dog training dataset, record the following:
 - How many images are included?
 - How are the images similar?
 - How are the images different?
 - b. For the cat training dataset, record the following:
 - How many images are included?
 - How are the images similar?
 - How are the images different?
3. Train your new classifier on your two new training datasets.

Once your classifier is finished, test your dataset with the cards given to you containing the following image. Fill in the table on the next page about your testing dataset:

Image	Classification	Confidence Score	Correct?
			
			
			



4. Did your new algorithm work?
- Better for dogs
 - The same for both cats and dogs
 - Better for cats

Solutions

A. Think and apply

- For the dog training dataset, record the following:
 - How many images are included? *Use the images from internet of dogs to train the model. Keep the images around 7 or 8 for dogs.*
 - How are the images similar? *Most images dont have any background images. The scale of the doc is almost similar. Most dogs are in standing/sitting position.*
 - How are the images different? *Training data contains images for different species of dogs.*
- For the cat training dataset, record the following:
 - How many images are included? *Use the images from internet of cats to train the model. Keep the images around 15 for cats.*
 - How are the images similar? *Most images dont have any background images. Most cats are in sitting position.*
 - How are the images different? *Training data contains images for different species of cats.*

3. Testing of Image Recognition Model. Based on the input images similar such results might appear. Note that the actual results may vary based on input training images.

Image	Classification	Confidence Score	Correct?
	Cat	90%	Yes
	Cat	90%	Yes
	Cat	70%	Yes
	Dog	80%	Yes
	Dog	60%	Yes
	Cat	70%	No
	Cat	60%	No

1. Which class did your classifier work better on? Why do you think that is?
 - a. Cats
 - b. Dogs

Cats. Because you provided more datasets for cats compared to dogs.

2. With your group, use the photos on the tables to re-curate your training dataset. Record the following:

Take another set of images to train the AI model.



a. For the dog training dataset, record the following:





- How many images are included? Use the images from internet of dogs to train the model. Keep the images around 15 for dogs.
- How are the images similar? Most images don't have any background images. The scale of the dog is almost similar. Most dogs are in standing/sitting position.
- How are the images different? Training data contains images for different species of dogs.

o For the cat training dataset, record the following:

- How many images are included? *Use the images from internet of cats to train the model. Keep the images around 15 for cats.*
- How are the images similar? *Most images don't have any background images. The scale of the cat is almost similar. Most cats are in standing/sitting position.*
- How are the images different? *Training data contains images for different species of cats.*

3. Testing of *Image Recognition Model*. Based on the input images similar such results might appear. Note that the actual results may vary based on input training images.

Image	Classification	Confidence Score	Correct?
	Cat	90%	Yes
	Cat	90%	Yes
	Cat	80%	Yes

	Dog	90%	Yes
	Dog	80%	Yes
	Cat	60%	No
	Dog	70%	Yes

4. Did your new algorithm work?

- Better for dogs
- ***The same for both cats and dogs***
- Better for cats

The training dataset is equal in numbers for both dogs and cats unlike previous training dataset.

Chapter 4: Ethics and Responsible AI

Exercise

A. Multiple Choice Questions.

- A. AI ethics focuses on:
- a) Making machines faster
 - b) Making machines cheaper
 - c) Ensuring responsible use
 - d) Deleting apps
- B. Privacy means:
- a) Sharing everything online
 - b) Protecting personal information
 - c) Hiding from society
 - d) Deleting apps
- C. AI bias can occur when:
- a) AI systems are turned off
 - b) Data used for training is incomplete or unfair
 - c) Computers are slow
 - d) The internet is not working
- D. Before sharing information online, what should you do?
- a) Share it quickly
 - b) Think about why the information is needed
 - c) Forward it to everyone
 - d) Ignore the message
- E. AI systems learn patterns from:
- a) Books
 - b) Data
 - c) Games
 - d) Images

B. Fill in the Blanks.

1. Misinformation mean _____ information.
2. Fair AI systems treat people _____.
3. Humans must remain _____ for AI decisions.
4. AI systems learn patterns from _____.
5. Incorrect or misleading information shared online is called _____.
6. Humans must remain _____ for decisions made using AI systems.

C. Short Answer Questions.

1. Why is privacy important in the digital world?
2. Give one example of misinformation.
3. What does accountability mean in AI systems?
4. What is AI ethics?
5. What is misinformation?
6. Why is human supervision important when AI systems are used?

D. Case-Based Questions.

1. A student installs an app that asks for permission to access location, contacts, and photos. The student pauses and thinks about why the app needs this information.
 - What important digital habit is the student practicing?
2. An AI system used in healthcare suggests that a patient has a high-risk level. Doctors carefully review the AI's recommendation before making a final decision.
 - Why is human review important in this situation?
3. An AI system is trained mostly with data from one city and later used in other places. The system does not work well for people from different regions.
 - What problem in AI does this example show?
4. A message spreads quickly on social media, but the information in it is incorrect.
 - What is this situation called, and what should users do before sharing such messages?

E. One-Word Challenge.

Write one word that matches the description:

Description	One word
Protection of personal information	
Incorrect or misleading information shared online	
Unfair patterns learned by AI from data	
Moral principles guiding technology use	
Responsibility for AI decisions	

Solutions

A. Multiple Choice Questions.

1. c) Ensuring responsible use
2. b) Protecting personal information
3. b) Data used for training is incomplete or unfair
4. b) Think about why the information is needed
5. b) Data

B. Fill in the Blanks.

1. false
2. equally
3. responsible
4. data
5. misinformation
6. accountable

C. Short Answer Questions.

1. Privacy protects personal information from misuse and keeps users safe online.
2. A fake message saying school is closed when it is actually open.
3. Accountability means humans are responsible for decisions made using AI.
4. AI ethics are rules that ensure AI is used fairly, safely, and responsibly.
5. Misinformation is false or incorrect information shared online.
6. Humans check AI decisions to prevent mistakes and unfair outcomes.

D. Case-Based Questions.

1. Thinking before sharing personal data / protecting privacy
2. To verify AI results and avoid incorrect medical decisions
3. **AI bias** (or **data bias**)
4. This is called **misinformation**.
Users should **verify the information before sharing**.

E. One-Word Challenge.

Write one word that matches the description:

Description	One word
Protection of personal information	Privacy
Incorrect or misleading information shared online	Misinformation
Unfair patterns learned by AI from data	Bias
Moral principles guiding technology use	Ethics
Responsibility for AI decisions	Accountability





CENTRAL BOARD OF SECONDARY EDUCATION

Academic Unit VI Floor, CBSE Integrated Office, Sector 23, Dwarka, New Delhi-110077