



Computational Thinking

Class 4

Teacher Handbook



First Edition: March, 2026

Country of Publication: India

Published by: Central Board of Secondary Education, Integrated Office, Sector 23, Dwarka, New Delhi-110077

PREFACE

The National Education Policy (NEP) aims to position India as a leader in emerging knowledge fields by integrating technologies like AI, Machine Learning, Big Data, and Computational Thinking into school education. It promotes technology-enabled, interactive, and gamified learning using tools such as Augmented Reality (AR), Virtual Reality (VR), and virtual labs to foster creativity, problem-solving, and interdisciplinary exploration. NCFSE 23 carries this recommendation further for implementation.

While Artificial Intelligence (AI) is an important requirement, Computational Thinking (CT) should be a broader skill, developing a foundation for learning AI. It can cover various aspects like Cybersecurity, basic network, etc. Hence, CBSE approaches this by integrating Computational Thinking with AI and other technological advancements, without dependence on any platform.

The book focuses on strengthening logical reasoning through structured visual, numerical, and real-life problems involving pattern progression, symmetry, transformations, ordering, and multi-step thinking. Learners engage with tasks that require comparing possibilities, identifying rules, and breaking problems into smaller parts. The document also outlines age-appropriate pedagogy, learning resources, assessment support, and classroom implementation guidelines to promote competency-based, experiential learning aligned with NEP 2020.

Team CBSE

ACKNOWLEDGEMENTS

Expert Committee

1. Dr. Karthik Raman, Core Leadership, IIT Madras Bodhan AI Foundation; Professor, Department of Data Science and AI, Wadhvani School of Data Science and AI, IIT Madras
2. Dr. Rajesh Kumar, Professor, Department of Electrical Engineering, MNIT, Jaipur
3. Dr. Seema Verma, Professor (ECE), Project Director (Siemens CoE), NITTTR, Bhopal
4. Dr. S. Neethi, Core Leadership, IIT Madras Bodhan AI Foundation; Professor of Practice, Department of Data Science and AI, Wadhvani School of Data Science and AI, IIT Madras
5. Dr. Arun L. Naik, Associate Professor, Mathematics Education, Azim Premji University, Bengaluru
6. Dr. Aanchal Chomal, Associate Professor, School of Continuing Education and University Resource Centre, Azim Premji University
7. Dr. Ankit Vijayvargiya, Assistant Professor, School of Technology, Dhirubhai Ambani University, Gandhinagar
8. Sh. R P Singh, Associate Prof & Additional Director, CBSE
9. Mr. Mikin Lala, (IIT Roorkee and IIM Calcutta Alumnus), Field Expert
10. Ms. Rekha Malhotra, (Alumna of British Institute (Business Management and Advertising), Frameworks Mumbai (Master's in Computer Science), and Workstation (3D Animation)), Field Expert

Material Production Group

1. Mr. Jay Thakkar, Senior Technical Officer, Centre for Creative Learning, IIT Gandhinagar
2. Mr. Chris John, Project Scientist, Centre for Creative Learning, IIT Gandhinagar
3. Mr. Mikin Lala, (IIT Roorkee and IIM Calcutta Alumnus), Field Expert
4. Ms. Amatullah Mustafa Neemuchwala, Field Expert
5. Ms. Telidevara Sree Lasya, Field Expert
6. Mr. Parth Oza, Field Expert
7. Mr. Deep Mayekar, Field Expert
8. Mr. Mayank Patil, Field Expert
9. Mr. Shivraj Ugale, Field Expert
10. Mr. Raj Dhorade, Field Expert
11. Mr. Nilesh Vijay Rajput, Field Expert

The efforts of Prof. Manish Jain and his whole team from Centre for Creative Learning, IIT Gandhinagar are also acknowledged and deeply appreciated.

TABLE OF CONTENTS

SR. NO.	CHAPTER	PAGE NO.
1.	Introduction	5
2.	How to Use This Book?	8
3.	Shapes Around Us	9
4.	Hide and Seek	16
5.	Patterns Around Us	24
6.	Thousands Around Us	35
7.	Sharing and Measuring	45
8.	Measuring Length	51
9.	The Cleanest Village	57
10.	Weigh It, Pour It	64
11.	Equal Groups	70
12.	Elephants, Tigers, and Leopards	75
13.	Fun with Symmetry	81
14.	Ticking Clocks and Turning Calendar	91
15.	The Transport Museum	97
16.	Data Handling	103

Introduction

Computational Thinking (CT) is a problem-solving approach that comprises Decomposition, Pattern Recognition, Abstraction, Algorithm Design, Data Analysis and Troubleshooting. Computational Thinking Skills involve solving complex problems that promote thinking skills such as critical & creative thinking, abstraction and pattern recognition, as well as algorithmic thinking. Problem identification and problem solving necessitate application of multidisciplinary understanding for creating effective solutions.

Artificial intelligence (AI) is a cutting-edge technology that empowers machines and computers to perform tasks that usually require mimicking human intelligence. These machines can perform complex thinking processes such as data analysis, pattern recognition, prediction of trends, solving problems and decision making. Thus, AI involves simulating cognitive processes associated with human intelligence and is widely applicable in various sectors such as banking, healthcare, defense, education, entertainment, agriculture and others for processing information, solving intricate problems and for planning.

The National Education Policy (NEP) aims for India to emerge as a global leader in new emerging knowledge domains such as artificial intelligence, machine learning, data analytics, 3-D machining etc. To realise this goal, the policy suggests teaching students Mathematics and Computational Thinking, along with new subjects like Artificial Intelligence, Machine Learning, and Data Science during their school education. The policy also focuses on technology-enabled learning and classrooms by using tools like artificial intelligence, machine learning, and adaptive testing to create knowledge.

The National Curriculum for School Education draws from this policy aspiration and emphasizes the need to introduce these emerging domains of study and technologies in the school curriculum. It recommends inclusion of subjects such as design thinking, augmented reality, virtual reality, artificial intelligence, and computational thinking. Additionally, it promotes the use of gamified content, interactive content, and immersive experiences (such as AR, VR, or virtual labs) to enhance student learning. In a variety of subjects, including design, music, art, and sciences, these resources support students in knowledge creation and exploration, and development of capacities such as problem-solving, critical and creative thinking.

CBSE, under the aegis of the Department of School Education and Literacy, Ministry of Education, Govt. of India, is implementing a Curriculum on Computational Thinking and Artificial Intelligence (CT & AI) to inculcate AI-readiness in school students. This curriculum will be implemented from classes 3rd to 8th, in the session 2026-27, and aims to develop AI-Ready learners, by focusing on Computational Thinking Skills. The AI-readiness, so inculcated through CT Skills, will help develop the capacities of learners to use computational thinking, such as logical thinking, problem solving, pattern recognition, and so on, and understand the role and use of Artificial Intelligence in daily life. The Curriculum aims to build strong foundations in computational thinking, digital literacy, and responsible use of technology, along with nurturing innovation, critical thinking, and ethical decision-making capacities.

1. Relevance: Importance of Introducing CT and AI

Introducing CT and AI at the Grade 4 level is vital for positioning students as future-ready digital citizens.

- **Foundation for AI:** Computational thinking is the intellectual backbone and cognitive framework required to understand and eventually create AI-driven solutions
- **Cognitive Development:** It fosters essential human capacities such as logical thinking, systematic problem-solving, and pattern recognition
- **Preparation for the Future:** Early exposure equips individuals with the ability to use data effectively and apply technology ethically, which is necessary for the modern world of work
- **Holistic Growth:** It promotes interdisciplinary learning, helping students see that knowledge is not compartmentalized by connecting Math, Science, and Humanities

2. Objectives (Curricular Goals)

For Grade 4 (part of the Preparatory Stage), the curriculum focuses on three primary goals:

- **CG-1:** Develop basic problem-solving skills with procedural fluency to solve daily-life problems as a step toward formal computational thinking
- **CG-2:** Develop basic capacities of analytical thinking, verbal, and visual reasoning
- **CG-3:** Demonstrate understanding of basic concepts of computers and knowledge of hardware and software

3. Learning Outcomes

ABSTRACT THINKING

Students will be able to solve moderate to highly moderate problems with partially visible or incomplete ideas, using:

- Different viewpoints of 3D objects
- Changes in shapes after flips, turns, cuts/folds, or rotations
- Hidden or missing parts in incomplete shapes or patterns
- Mirror images and identical halves based on symmetry

PATTERN RECOGNITION

Students will be able to identify patterns involving one or more changes in consecutive terms, formed using:

- Numbers
- Shapes or images
- Letters
- Or a mix of the above

DECOMPOSITION

Students will be able to break down problems involving a cluster of moderate clues, using information from:

- Number clues (place values, sum/difference/product)
- 3D objects and their parts (faces, edges, corners)
- Step-by-step exchanges or transfers (money, objects, digits, quantities)
- Tables or charts with multiple pieces of information
- Conditions for counting/grouping/sorting items

ALGORITHMIC THINKING

Students will be able to follow a set of well-defined, elaborate conditions to solve moderate to complex problems involving:

- Number sequences formed using simple operations
- Movements on grids or direction-based paths
- Values that increase or decrease across steps
- Multi-step instructions involving moves, changes, transfers, swaps
- People/Events arranged in an order using attributes or chronological clues
- Simple counting instructions

4. Mapped with NEP and NCF 2023

The curriculum is directly aligned with national educational reforms:

- **NEP 2020 Vision:** It fulfils the goal of making India a global leader in emerging domains like AI and Machine Learning by integrating them into school education
- **NCF-SE 2023 Alignment:** The learning standards (Goals Competencies Outcomes) are derived from the framework suggested in the National Curriculum Framework for School Education 2023
- **Phased Implementation:** Following NCF recommendations, the curriculum introduces CT first as a basis for learning AI later in higher classes

5. Time Allocation

- **Annual Hours:** A total of 50 hours annually is suggested for the Preparatory Stage (Classes 3–5)
- **Balanced Integration:** To avoid overburdening students, this time is not added as an extra subject but is integrated into existing Mathematics and "The World Around Us" (TWAU) periods

6. Approach / Pedagogy

The pedagogical approach for Grade 4 is designed to be playful and experiential:

- **Activity-Based:** Learning is driven by fun math games, puzzles, and hands-on exercises using specialized worksheets
- **Problem-Solving Focus:** Teachers guide students to break larger problems into smaller parts and interpret visual representations like charts and diagrams
- **Collaborative Learning:** The curriculum emphasizes peer discussions and group tasks to solve problems collectively

7. Assessment

Assessment for Grade 4 shifts from rote memorization to continuous and competency-based methods:

- **Interactive Tools:** Methods include written tests with CT puzzles, interactive group activities and the use of a Teacher Observation Journal to track progress
- **Qualitative Focus:** The goal is to assess a student's ability to apply knowledge and think creatively

How to Use This Book?

This book is designed as a companion to the Mathematics textbook and is intended to be used alongside regular classroom teaching. Since it follows the same chapter sequence, the Mathematics teacher can seamlessly integrate it into daily instruction. As concepts are introduced in class, the corresponding questions from this book can be used to deepen understanding and encourage application.

Before beginning a chapter, the teacher is encouraged to go through the content of this book, identify the underlying concepts required for each question, and plan how to align them with classroom teaching. As these concepts are taught, the teacher can introduce the related thinking questions to students.

It is important to note that the questions in this book are thinking-based and designed to promote analysis, reasoning, and problem-solving. Teachers should adopt a facilitative approach, guiding students through prompts and discussions rather than directly providing solutions. Students should be given time to think and attempt independently, followed by classroom discussions where different approaches are shared and explored.

Some chapters also include activities that build intuition and engagement. These should be conducted before attempting the questions, as they help students approach the problems with better understanding.

Teachers should approach this book with the mindset that the process of thinking is more important than arriving at the correct answer. Creating a safe and encouraging environment where students feel comfortable making mistakes, exploring multiple strategies, and expressing their reasoning is essential. The goal is to nurture confident, independent thinkers rather than focus solely on correctness.

Chapter 1: Shapes Around Us

1. What will come in place of "?"

Note: You cannot rotate the images

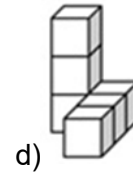
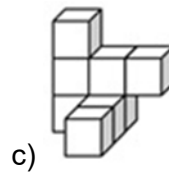
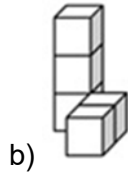
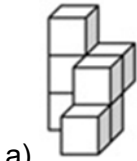
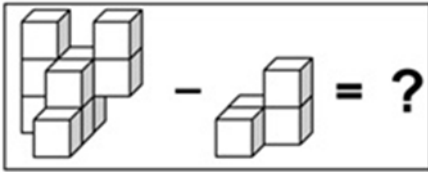

Answer: d

Solution:

We have to subtract corresponding cubes, position-wise.

Figure out the blocks corresponding in both figures (check for the exact arrangement which is being subtracted from the bigger arrangement):

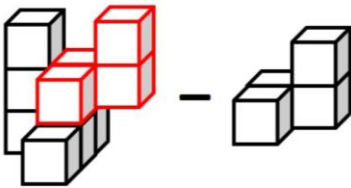

We get,

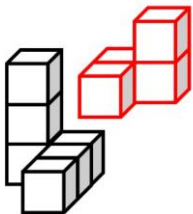

Hence, we are left with:

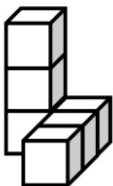

Therefore, option d is correct.

2. The figure below forms a cube when folded. Which of the following options represents a pair of opposite faces of the cube?

Note: You cannot rotate the question or option images

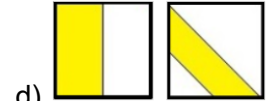
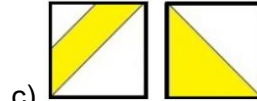
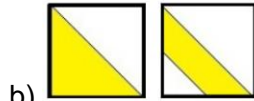
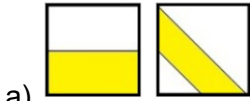
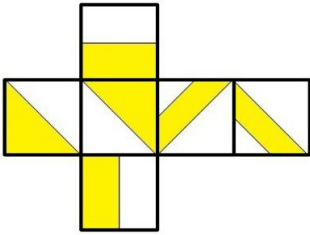

Answer: c

Solution:

Let us first number the faces to avoid confusion.

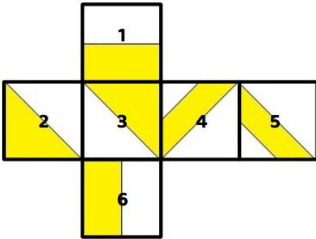

Let's identify the pairs of opposite faces.

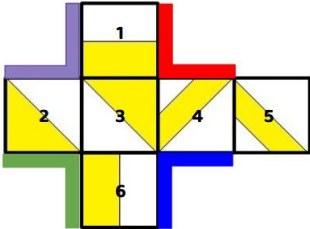

As shown above, edges of the same colour are joined together to give the cube shape to the net.

The faces 1, 2, 4, and 6 are made to stand upright to form the cube.

Then, face 5 closes as a lid on the top to complete the cube shape.

Hence, the pairs of opposite faces in the final cube are:

1 and 6

2 and 4

3 and 5

Now, let's analyse each of the following options.

Option a:

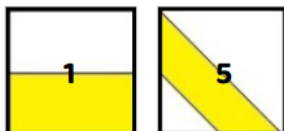

Faces 1 and 5 are not opposite. Hence, option a is invalid.

Option b:

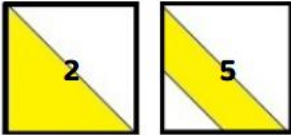

Faces 2 and 5 are not opposite. Hence, option b is invalid.

Option c:

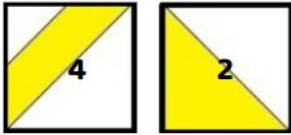

4 and 2 are opposite faces. Hence, option c is correct.

Option d:



Faces 6 and 5 are not opposite. Hence, option d is invalid.

Hence, option c is the correct answer.

3. From a rectangular piece of paper, a shape having which of the following number of angles **CANNOT** be formed by making only a **SINGLE STRAIGHT CUT** in any direction?

- a) 3 angles b) 4 angles c) 5 angles d) 6 angles

Answer: d

Solution:

When we cut the rectangular piece of paper in a single straight cut, the following shapes can be formed:

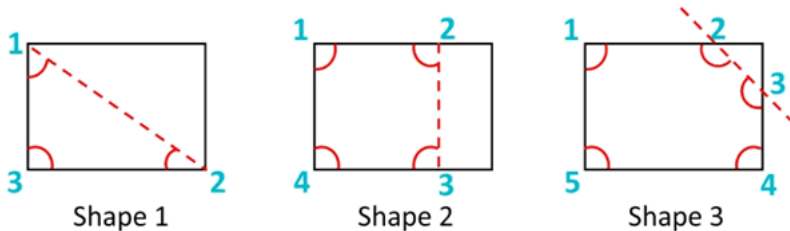

Shape 1 has 3 angles after cutting.

Shape 2 has 4 angles after cutting.

Shape 3 has 5 angles after cutting.

A shape having 6 angles cannot be formed after cutting. Hence, the correct answer is option d.

4. Count the number of **TRIANGLES** in the image given below.



- a) 4 b) 5 c) 3 d) 2

Answer: a

Solution:

As highlighted in the image below, the figure contains 4 TRIANGLES.

Hence, the correct answer is option a.

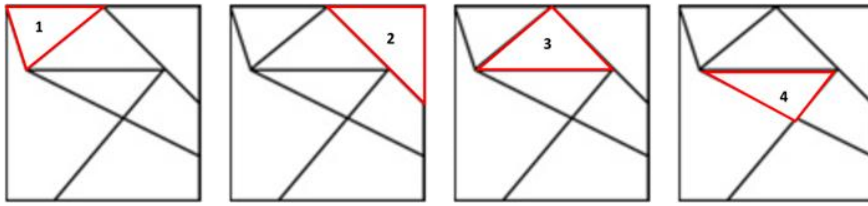

5. Find the ODD one out.



Answer: a

Solution:

The letter inside every shape is the first letter of its spelling and the number inside every shape is the number of sides of that shape. Only option a does not follow this rule. Hence, the correct answer is option a.

6. If each of the given terms follows the same theme, what will come in place of "?"

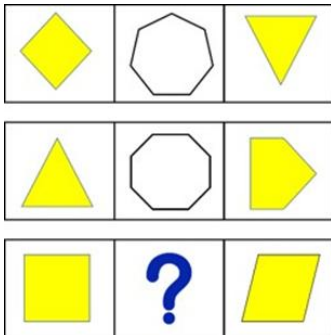

Answer: b

Solution:

In each row, the total number of sides of the two yellow shapes gives the number of sides of the shape in the middle. In the third row, there is a square and a parallelogram. $4 + 4 = 8$. Option b has 8 sides. Hence, it is the answer.

7. Each face of a triangular prism is coloured with a colour in such a way that no two adjacent faces have the same colour. What is the MINIMUM number of colours required to do this?

Note: Two faces are said to be adjacent if they share a common edge



Answer: c

Solution:

As shown in the image, there are 3 faces in the prism which would be adjacent to the front triangle face (shown in yellow).

So, all these four faces (including the triangle face) need to be coloured with different colours. The two triangle faces are not adjacent to each other. So, they'll be coloured with the same colour (yellow). Hence, the MINIMUM number of colours needed to satisfy the given condition is 4.

So, the correct answer is option c.

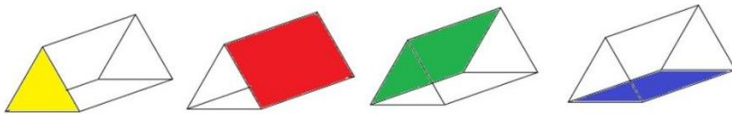

8. Which of these shapes will come in place of A and B, such that no two shapes having the same number of sides, pattern, or colour appear in the same row or column?

Note: Not all blocks will necessarily have a shape present in them

B		
		A

a) $A =$ $B =$

b) $A =$ $B =$

c) $A =$ $B =$

d) $A =$ $B =$

Answer: a

Solution:

Let's begin with determining the shapes that can replace A and B, where we need to follow these conditions:

- The shape for A should not have the same number of sides, pattern, or colour as the shapes in the same row or column.
- Similarly, the shape for B should not have the same number of sides, pattern, or colour as the shapes in the same row or column.

Option b is eliminated because the same pattern is present inside a shape in the same column as A and shape of B is same as the pentagon in its row.

$A =$ $B =$

B		
		A

Option c is eliminated because shapes in white colour are present in the same row and column as A.

$A =$ $B =$

B		
		A

Option d is eliminated because the same shape is present in the same row as B.

$A =$ $B =$

B		
		A

Shapes in option a satisfy all the conditions. Hence, the correct answer is option a.

$A =$ $B =$

9. Six concrete blocks of cubical shape are used for building the stairs as shown below. How many faces of these blocks are not visible?

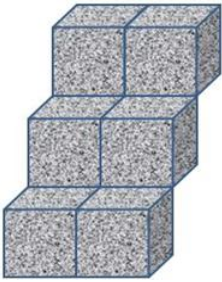

- a) 12 b) 15 c) 21 d) 24

Answer: c

Solution:

There are 6 cubical blocks in the figure.

Since a cube has 6 faces, the total number of faces would be: $6 \times 6 = 36$.

Since in the figure we can see a total of 15 faces only, the number of hidden faces would be: $36 - 15 = 21$.

OR

Let us divide the figure into two portions - left side and right side.

Left side: 2 faces of each of the blocks are visible. For 3 cubes, we can see only 6 out of the 18 faces. Therefore, 12 faces are hidden.

Right side: 3 faces of each of the blocks are visible. For 3 cubes, we can see only 9 out of the 18 faces. Therefore, 9 faces are hidden.

Therefore, 21 faces (12+9) are hidden.

Option c is correct.

10. How many edges of the pyramid shown below have a yellow dot at one of their corners but do not have a red dot on the other corner?

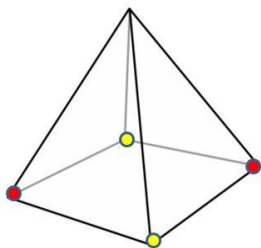

- a) 1 b) 2 c) 3 d) 4

Answer: b

Solution:

As highlighted below, two edges of the pyramid have a yellow dot at one of their corners but do not have a red dot on the other corner. Hence, the correct answer is option b.

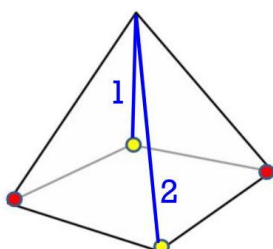



The Thinking Spot

All the shapes of Set A must be placed into the squares present in Box 1, such that

- Each square has EXACTLY ONE shape
- The shape and the square CANNOT be of the same colour
- Two squares connected by a line CANNOT have the same shape inside them

Which option shows the shapes which are NOT next to each other in the final arrangement?

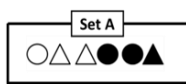
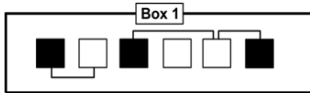

Answer: a

Solution:

We need to place the shapes from Set A according to the given conditions. Each square can hold only one shape, and the shape cannot be of the same colour as the square. Additionally, the squares that are connected cannot contain the same shape. Following these rules, let's begin placing the shapes from Set A into Box 1. For this, we have to logically identify the starting step, a step in which we can accommodate a maximum number of shapes.

Consider this white square. It can either have a black triangle (case 1) or a black circle (case 2).

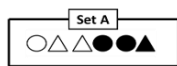
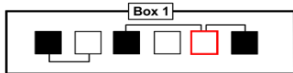

If this white square has a black triangle, the two black squares that are connected to it must have two white circles. (As the black squares cannot have a triangle again) However, this case is not possible, as our Set A does not have two white circles.

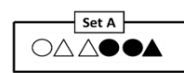
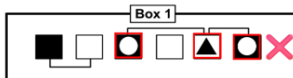

Hence, the white square has a black circle, and the black squares have white triangles.

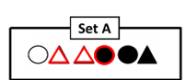
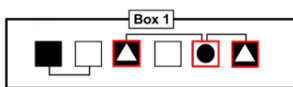

Now, let's consider this connected pair. Since connected squares must have different shapes, the only white shape left, the white circle, goes in the black square. Therefore, the white square must have a black triangle. (As a black circle cannot be placed here).

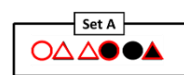
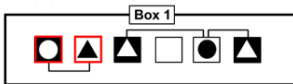

Finally, the black circle which is left in Set A must be placed in the empty white square.

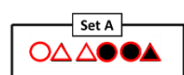
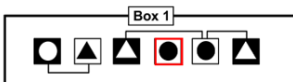

Clearly, the black triangle and the black circle are NOT next to each other.

So, option a is the correct answer.



3. A, B, C, and D each go to one of the following places: the Zoo, the Shop, the Cafe, and the Gym.
- Each person visits a DIFFERENT location and starts from a DIFFERENT white square
 - B reaches the Gym in exactly 1 turn
 - A reaches the Cafe in exactly 2 turns
 - D did not take any turns to reach his destination

Who among them started from the square having the question mark?

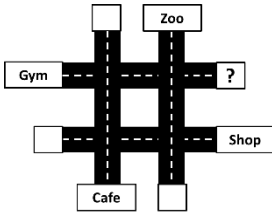

- a) A b) B c) C d) D

Answer: c

Solution:

Let us first label the empty boxes as 1, 2, 3, and 4.

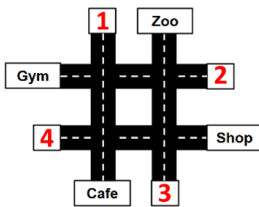

B reaches the Gym in exactly one turn. 1 and 3 are the positions from which B can reach the Gym in exactly one turn.

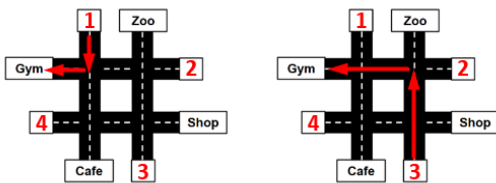

A reaches the Cafe in exactly two turns. Thus, A is at position 3. So, B has to be at 1.

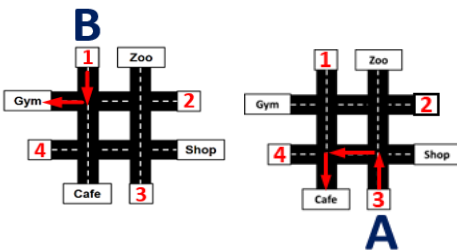

The remaining destinations are Shop and Zoo, and the remaining positions are 2 and 4.

A person starting from 2 needs to take turns to go to any destination, while a person starting from 4 can go straight to the Shop without taking any turns.

Since D did not take any turns to reach his destination, D must be at 4, and C must be at 2 as it is the only position remaining.

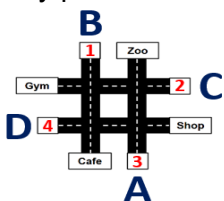

Hence, the correct answer is option c.

4. Sam wants to reach HOME by walking along the GREY STRIP. Identify the missing part of the strip.

Note: You are not allowed to rotate any of the option images

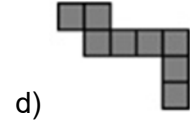
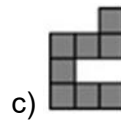
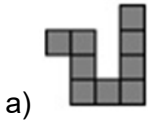
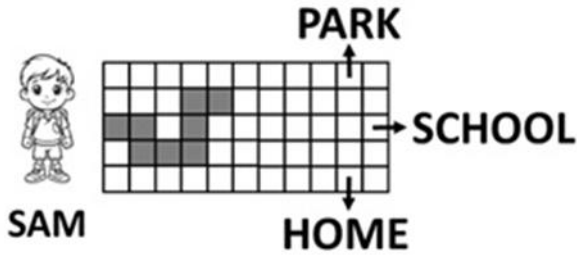

Answer: d

Solution:

Let's solve this logically.

As 'HOME' is at the bottom of the grid, we need to choose a path that ends at the bottom portion of the grid.

Based on this, options a and b can be eliminated, as their paths end upwards and sideways, as shown below:

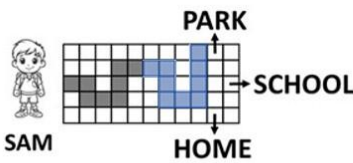

Option a

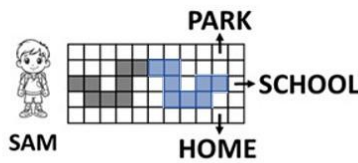

Option b

Now, examine option c.

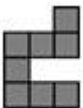

This path might take Sam to the bottom portion, but it does not have sufficient grey cells to make him reach 'HOME', as shown below:

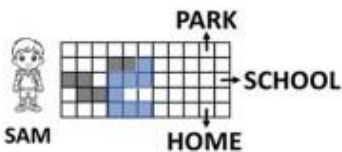

Option c

As we can see in the given image, option d will allow Sam to reach 'HOME'. Hence, the correct answer is option d.

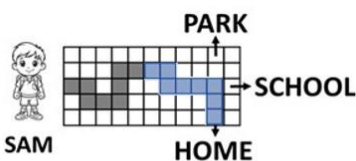

Option d

5. In the grid given below, which letter has the MOST number of arrows pointing towards it?

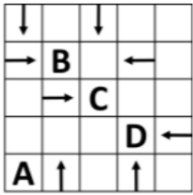

- a) A b) B c) C d) D

Answer: b

Solution:

Let's check each of the options one by one and see which letter has the highest number of arrows pointing towards it.

- Option a: As shown in Image 1, A has 1 arrow pointing towards it.
 Option b: As shown in Image 2, B has 3 arrows pointing towards it.
 Option c: As shown in Image 3, C has 2 arrows pointing towards it.
 Option d: As shown in Image 4, D has 2 arrows pointing towards it.

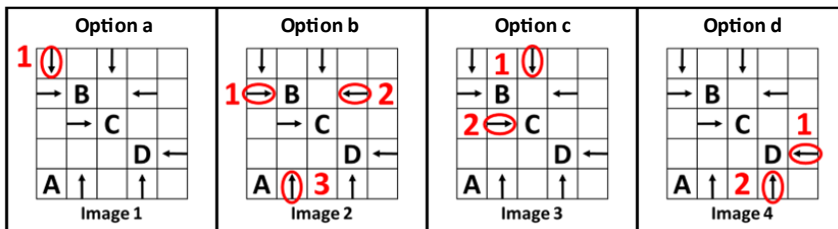

Since B has 3 arrows pointing towards it, which is the highest number of arrows pointing towards any letter, option b is the correct answer.

6. Which of the following options is the top view of the question image?

Note: You cannot rotate the question or option images

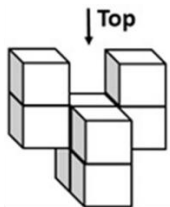

Question Image

- a) b) c) d)

Answer: c

Solution:

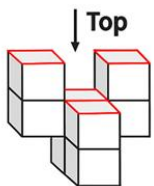

As shown in the image, four blocks are visible when viewed from the top. In this view, three blocks are arranged in a straight line, and the fourth block is positioned below the middle one, forming a T-shaped pattern. Hence, the correct top view is option c.

7. Which of the views given in the options shows the highest number of different colours?

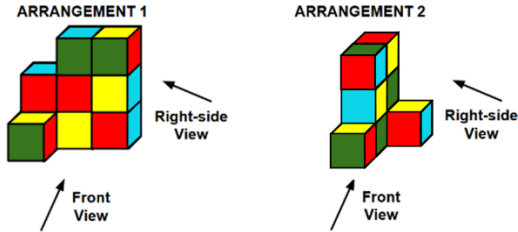

- a) Front View – ARRANGEMENT 1
- b) Right-side View – ARRANGEMENT 1
- c) Front View – ARRANGEMENT 2
- d) Right-side View – ARRANGEMENT 2

Answer: d

Solution:

Let's check each of the given options:

Option a) Front View – ARRANGEMENT 1:

When ARRANGEMENT 1 is viewed from the front, Red, Green, and Yellow, are visible.

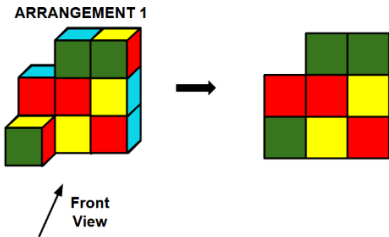

Option b) Right-side View – ARRANGEMENT 1:

When ARRANGEMENT 1 is viewed from the right, Red and Blue are visible.

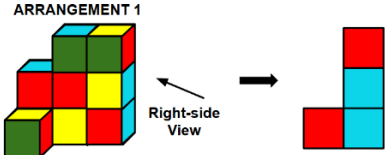

Option c) Front View – ARRANGEMENT 2:

When ARRANGEMENT 2 is viewed from the front, Red, Green, and Blue, are visible.

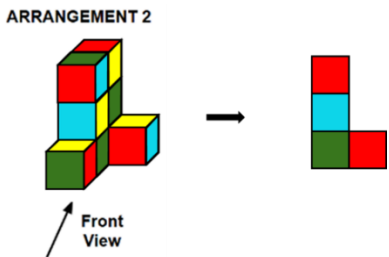

Option d) Right-side View – ARRANGEMENT 2

When ARRANGEMENT 2 is viewed from the right, Red, Yellow, Green, and Blue, are visible.

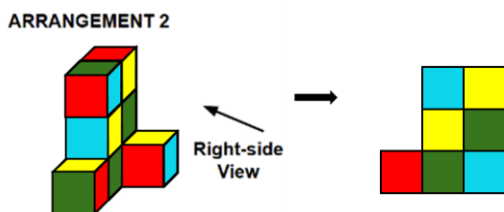

Since 4 different colours are visible, the correct answer is option d.

8. Which of the following options will look like Figure X when viewed along the direction of the arrow? Note: You cannot rotate the question or option images

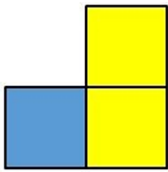

X

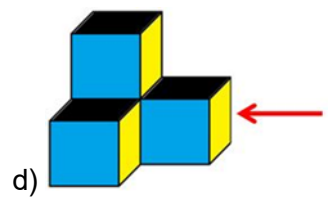
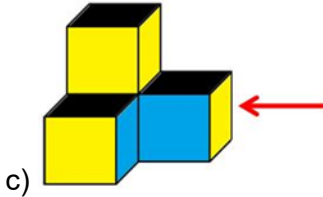
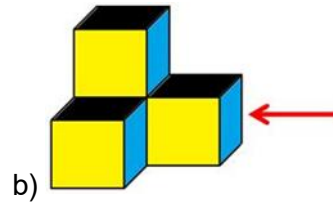
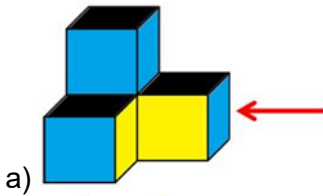

Answer: c

Solution:

We will analyse the view of each option from the given direction and then see if it matches with the Figure X.

Option a: The right-side view doesn't match Figure X.

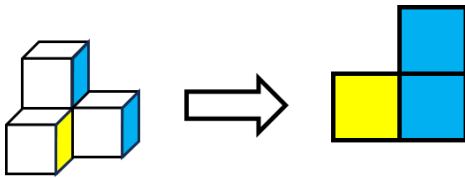

Option b: The right-side view doesn't match Figure X.

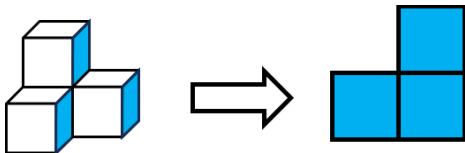

Option c: The right-side view is exactly the same as Figure X.

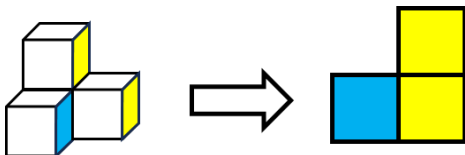

Option d: The right-side view doesn't match Figure X.

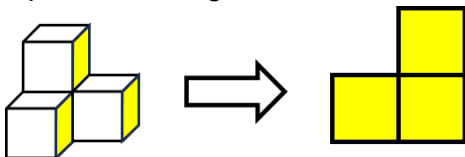

Thus, option c is the only option whose view from the given direction matches Figure X. Hence, the correct answer is option c.

9. If a person is standing on block number 3, facing the animals, what will be the position of the cat with respect to the fox from his point of view?

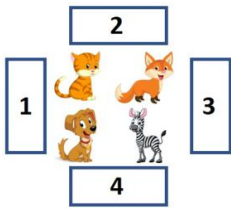

- a) In front b) Behind c) Left d) Right

Answer: b

Solution:

According to the image, if the person is standing on block number 3, **the cat will be behind the fox.** Option b is correct.

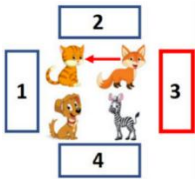

10. Which of the following figures is the top view of the solid?

Note: You cannot rotate the question or option images

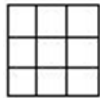
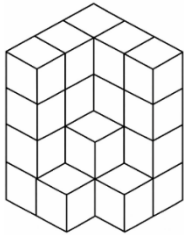

a)

b)

c)

d)

Answer: a

Solution:

Top view is the view you get when you see any solid from the top.

If you see the solid from the top, you will be able to see only the blue faces as highlighted in the image below. Thus, option a is the right answer.

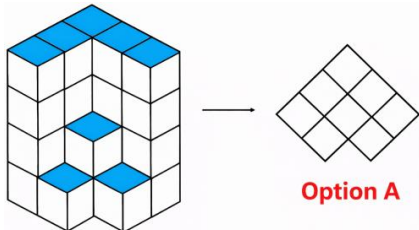

Option A



The Thinking Spot

Ten coins are distributed among four people P, Q, R, and S such that one of them gets one coin, another gets two coins, the third gets three coins, and the fourth gets four coins. It is known that Q gets more coins than P; and S gets fewer coins than R.

If R gets at least two more coins than S, then which one of the following is necessarily true?

- (a) Q gets at least two more coins than S
- (b) Q and R together get seven coins every time
- (c) P gets more coins than S
- (d) P and Q together get at least five coins

Answer: b

Solution:

From the question we can deduce that $Q > P$ and $R > S$.

Now, if R gets at least 2 more than S, then the combination of coins distributed to S and R could either be (1,3), or (1,4), or (2,4).

Case 1: $S = 1, R = 3, P = 2,$ and $Q = 4$

Case 2: $S = 1, R = 4, P = 2,$ and $Q = 3$

Case 3: $S = 2, R = 4, P = 1,$ and $Q = 3$

In every case, Q and R together always have 7 coins.

Thus, option b is the correct answer.



Chapter 3: Patterns Around Us

Activity Time

Odd and Even Numbers

Activity: Coin Flip Magic

Introduction

Using the concept of parity, which refers to the evenness or oddness of a number, we can identify the change in certain patterns. These methods are used to analyse errors in our communication systems. Here, we will explore an activity in which we play with two coloured coins (Black and White) arranged in a grid to mimic data. We will flip a coin to simulate an error in the data. The activity describes a procedure for precisely detecting errors in the grid pattern.



Activity	Time	Description
Launch	5 min	Teacher demonstrate the activity Supporting Links: Activity Video Link: https://youtu.be/-t9VrqB0mz8?si=MGs2XOpU2hr035Zs Reference: https://www.csunplugged.org/en/topics/error-detection-and-correction/
Trial by Students	15 min	Student's Tryout the activity with each other. Student Worksheet: https://docs.google.com/document/d/1nbcoVKiETeE-4ta4zeppEcVCCs3NhznYJuWEvhmaFy4/edit?usp=sharing
Discussions and Explorations	15 min	Attempting the worksheets and the discussion based on the activity

CT Components

Algorithmic Thinking:

When we count the number of black coins in each row, one by one, and check whether the number is even or odd, and we do the same thing for every column. Repeating these steps for every row and column follows a clear algorithm to pinpoint the flipped coin.

Decomposition:

To identify the flipped coin, we break it down into steps: focus on one row, ask whether it has an even or odd number of black cards, and do the same for every column.

Generalisation:

Once students understand the algorithm for identifying flipped coins, they will be able to find a flipped coin on any size grid.

Logic:

By flipping any coloured coin, an even number of black coins in a row/column changes to an odd number.

Abstraction:

Grid patterns are a representation of data, and error in the data is represented by flipping the coin.

Activity: Coin Flip Magic

You have a grid and double-coloured coins with black and white sides. Ask someone to randomly arrange the coins, white side up or black side up, in a 4×4 grid pattern. This will ensure that you are not familiar with the pattern. You will add one more row and one more column, creating a 5×5 grid pattern with the following details in mind. While adding the extra row and column, ensure each row and column has an even number of black sides up (zero is also even). Close your eyes and have someone flip any one coin on the grid pattern. When you open your eyes, you can figure out which coin was flipped. Let us see how?

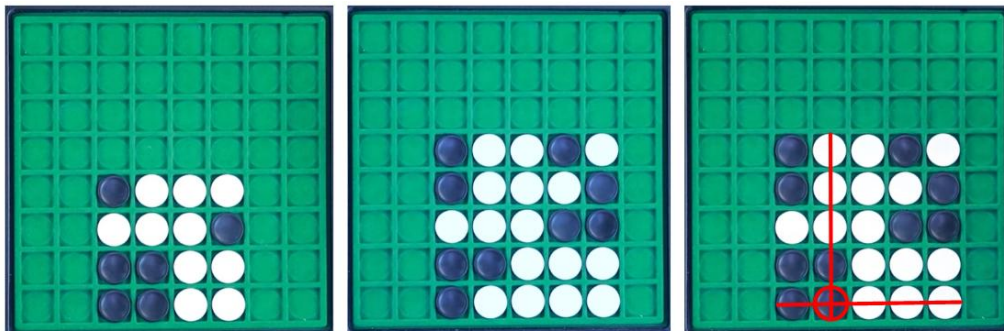

Figure: Activity Setup and Trick

1. **When we flipped the black coin in the 5th row and 2nd column, what changes in the given row and column?**
 - a) The number of white coins increases, and it becomes odd
 - b) The number of black coins decreases, and it becomes odd
 - c) The number of black coins increases, and it becomes odd
 - d) The number of white coins decreases, and it becomes odd

Answer: b

Solution:

You will notice that when you flip a coin with a black side up, the number of black sides up in a given row and column decreases, and it becomes odd.

By observing rows and columns that have an odd number of black coins, we can figure out which coin was flipped in the activity.

Competency:
Decomposition
Logic

:

Explorations

1. Based on what you saw above, can you identify which coin was flipped in the given grid pattern?

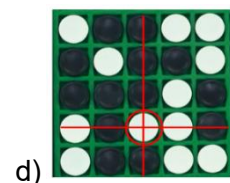
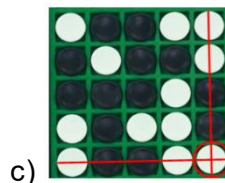
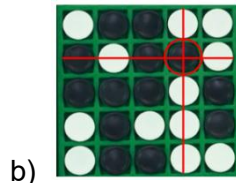
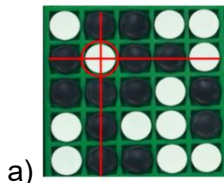
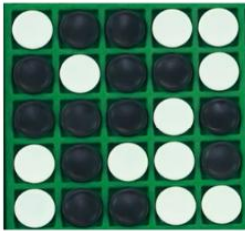

Answer: b

Solution:

Observe that in the highlighted 2nd row and 4th column, the number of black coins is odd in number. By observing rows and columns that have an odd number of black coins, we can figure out which coin was flipped in the activity.

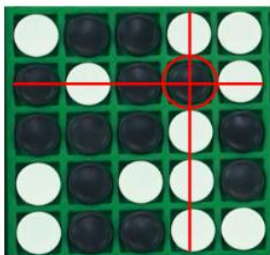

Competency:
Decomposition
Logic

2. For the given 3 x 3 grid pattern, which would be the corresponding 4 x 4 grid pattern that will help to detect which coin was flipped?

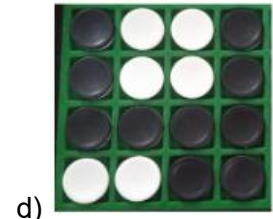
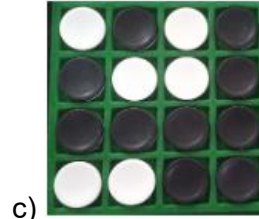
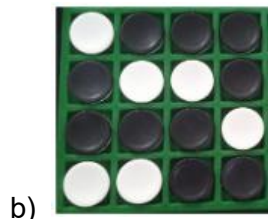
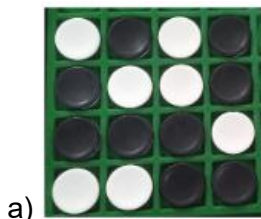

Answer: c

Solution:

In the grid pattern, observe that in all rows and columns, the number of black coins is even in number.



Competency:

Generalisation
Decomposition
Logic

3. Instead of a 4x4 grid pattern, if we started with a 6x6 grid pattern, how many coins would be needed for the extra row and column?

a) 13

b) 14

c) 15

d) 16

Answer: a

Competency:

Generalisation
Decomposition
Logic

The Flip "trick" is really not a magic trick at all. It is a precise algorithm based on the concept of **parity**. Parity refers to the **evenness or oddness** of a number.

Remember, while adding the extra row and column, we ensured that each row and column has an even number of black coins. These extra coins are called parity coins. These parity coins help us track the "**evenness**" of the black coins before the flip and the change in "**evenness**" after the flip. This tracking is done by identifying the row and column which has an odd number of black coins.

Questions

1. Given below are 8 squares, to be filled with unique numbers from 1 to 8, and some numbers are already filled as shown below.

If the result of all the four operations is always a single-digit ODD NUMBER, then which of the following can NEVER be the result of any operation?

$$\boxed{3} + \boxed{} =$$

$$\boxed{8} - \boxed{} =$$

$$\boxed{2} + \boxed{} =$$

$$\boxed{7} - \boxed{} =$$

- a) 1 b) 3 c) 5 d) 7

Answer: c

Solution:

Some numbers are already placed in the grid, while the remaining numbers to be filled are 1, 4, 5, and 6. Since the result must always be a single-digit odd number, each odd number should be paired with an even number and vice versa.

In the given squares, 3 and 7 (odd numbers) are already present. From the available numbers, the even numbers 4 and 6 can be placed with 3 and 7 as shown below.

CASE I

$$\boxed{3} + \boxed{4} = 7$$

$$\boxed{8} - \boxed{} =$$

$$\boxed{2} + \boxed{} =$$

$$\boxed{7} - \boxed{6} = 1$$

CASE II

$$\boxed{3} + \boxed{6} = 9$$

$$\boxed{8} - \boxed{} =$$

$$\boxed{2} + \boxed{} =$$

$$\boxed{7} - \boxed{4} = 3$$

Similarly, 8 and 2 (even numbers) are already in the grid, and the remaining odd numbers, 1 and 5, can be paired with them accordingly as shown below.

CASE I

$$\boxed{3} + \boxed{} =$$

$$\boxed{8} - \boxed{5} = 3$$

$$\boxed{2} + \boxed{1} = 3$$

$$\boxed{7} - \boxed{} =$$

CASE II

$$\boxed{3} + \boxed{} =$$

$$\boxed{8} - \boxed{1} = 7$$

$$\boxed{2} + \boxed{5} = 7$$

$$\boxed{7} - \boxed{} =$$

After placing all the numbers following this pattern, 5 never appears as a result in any case. Hence, the correct answer is 5. Hence, the correct answer is option c.

2. XY is a two-digit odd number. The sum of X and Y is a single-digit odd number. At maximum, how many different possible values can X have?

- a) 2 b) 3 c) 4 d) More than 4

Answer: c

Solution:

XY is a two-digit odd number.

Y is definitely an odd digit.

Now, we don't know whether X is even or odd.

But it is given that the sum of X and Y is a single digit odd number.

If Y is an odd number and the sum of X and Y is a single digit odd number, then X should be an EVEN number. (Since Odd digit + Even digit gives an odd number)

X can be 2, 4, 6 or 8. (X cannot be 0, as XY wouldn't be a 2-digit number)

Therefore, X has 4 different possible values.

Thus, option c is the correct answer.

3. Six consecutive even numbers are written on the faces of a single dice. If the smallest number is 8, then what will be the largest number?

a) 18

b) 28

c) 16

d) 20

Answer: a

Solution:

Six consecutive even numbers starting from 8 are 8, 10, 12, 14, 16, and 18.

The largest number will be 18.

Thus, option a is the correct answer.

4. What will come in place of "?" in the given series?

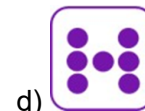

Answer: d

Solution:

As shown in the figure below:

The odd positioned terms are consecutive numbers starting from 2. The even positioned terms are consecutive numbers starting from 4. So, the next term will contain 7 dots.

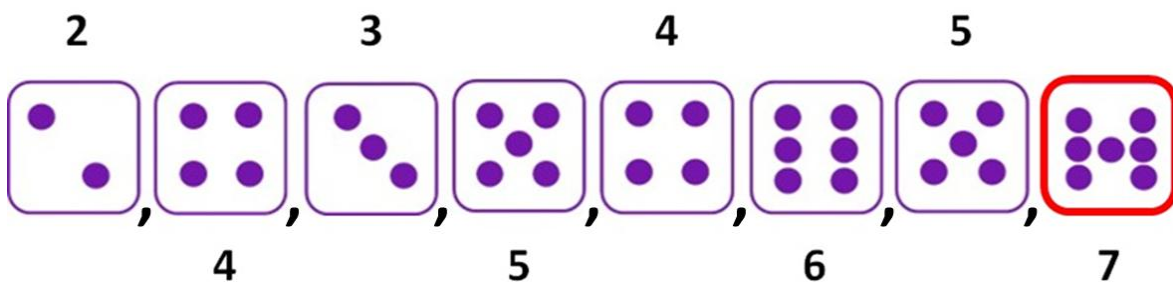

Hence, the correct answer is option d.

5. What will come in place of "?"

9	3	8
1	5	6
2	4	7

→

9	3	●
1	5	●
●	●	7

10	11	9
1	6	7
3	2	8

→

●	11	9
1	●	7
3	●	●

20	13	17
29	26	14
33	5	8

→

●	13	17
29	●	●
33	5	●

28	14	18
15	32	23
31	51	10

→
?

a)

●	●	●
15	●	23
31	51	10

b)

●	●	●
15	●	23
●	51	10

c)

●	●	●
15	●	23
31	51	●

d)

●	●	18
15	●	23
31	51	●

Answer: c

Solution:

Even numbers on the left-hand side are replaced with a black coloured circle on the right side. Based on this rule, option c is the correct answer.

6. Diya wants to pick only the items placed on the steps marked with even numbers. Which of the following options shows the food items she would collect?

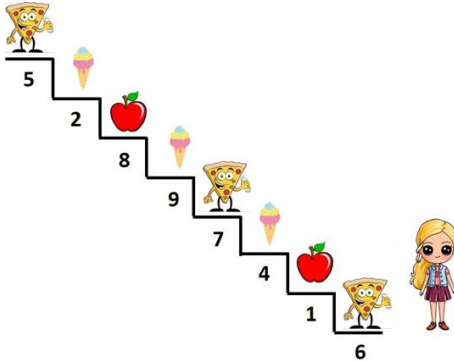

a) 2 Pizzas, 2 Ice-creams, and 1 Apple

c) 1 Pizza, 2 Ice-creams, and 1 Apple

b) 1 Pizza, 1 Ice-cream, and 2 Apples

d) 2 Pizzas, 1 Ice-cream, and 1 Apple

Answer: c

Solution:

Out of the given numbers, even numbers are 6, 4, 8, and 2. Hence, Diya will pick the following:

6 = Pizza

4 = Ice-cream

8 = Apple

2 = Ice-cream

i.e. 1 Pizza, 2 Ice-creams, and 1 Apple.

Hence, the correct answer is option c.

7. Mani has some sweets with him. He wants to divide them between him and his friend Swami equally. He tries many times but is not able to divide the sweets equally. What could be the reason?

Note: A full sweet cannot be split into parts

- a) The number of sweets that Mani has is even b) The number of sweets that Mani has is odd
 c) The number of sweets that Mani has is 46 d) None of these

Answer: b

Solution:

If Mani tries many times but still cannot divide the sweets equally between the two of them, it means the number of sweets must be odd. An odd number cannot be split into two equal whole numbers. So, the correct answer is option b.

8. **Statement: The sum of two natural numbers is 39.**

Which of the given options can be understood from the given statement?

- a) One of the two natural numbers is odd b) Both the natural numbers are odd
 c) One of the two natural numbers is even d) Both a and c

Answer: d

Solution:

The sum of two natural numbers can be odd only if one of them is even and the other is odd. Hence, both first and third options can be understood. Hence, the correct answer is option d.

9. **There are only 4 people, A, B, C, and D, standing in a queue.**

1. A is not standing at an even-numbered position from the front

2. D is standing immediately ahead of B

If B is not standing last, then who is standing last?

- a) A b) B c) C d) D

Answer: c

Solution:

There are only 4 people, A, B, C and D, standing in a queue. Let us have 4 positions from the front to the back of the queue.

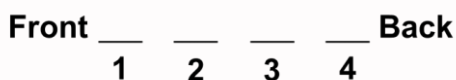

A is not standing at even numbered places from the front.

So, A must be standing either at positions 1 or 3.

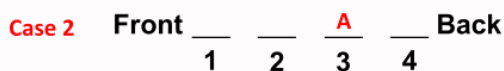
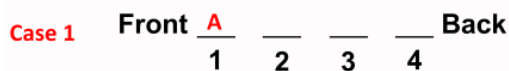

D is standing immediately ahead of B.

So, Case 1 will have 2 different possible positions for D and B.

Case 2 has only one possible placement for D and B.

All of them are shown as follows:

Case 1 - a Front $\frac{A}{1}$ $\frac{D}{2}$ $\frac{B}{3}$ $\frac{\quad}{4}$ Back

Case 1 - b Front $\frac{A}{1}$ $\frac{\quad}{2}$ $\frac{D}{3}$ $\frac{B}{4}$ Back

Case 2 Front $\frac{D}{1}$ $\frac{B}{2}$ $\frac{A}{3}$ $\frac{\quad}{4}$ Back

But B is not standing at the last position. So, Case 1 - b is invalid.
Clearly, in the remaining cases, we can see that C is standing at the last position.

Case 1 - a Front $\frac{A}{1}$ $\frac{D}{2}$ $\frac{B}{3}$ $\frac{C}{4}$ Back

Case 2 Front $\frac{D}{1}$ $\frac{B}{2}$ $\frac{A}{3}$ $\frac{C}{4}$ Back

Hence, option c is the correct answer.

10. If any 4 odd numbers in the figure shown below are connected in the ascending order by using straight lines, then which of the following figures CANNOT be made?

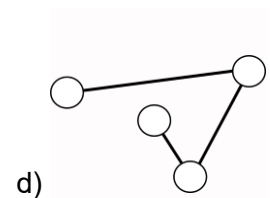
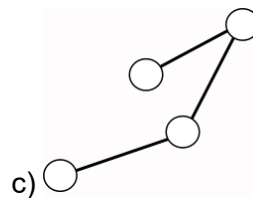
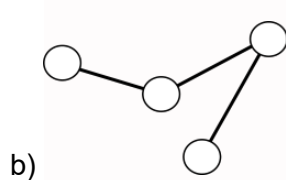
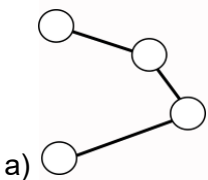
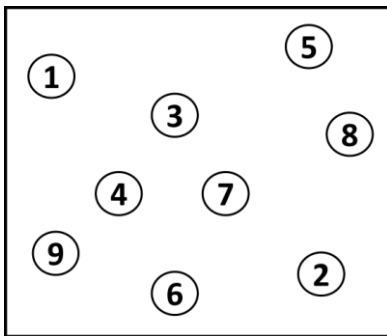

Answer: d

Solution:

As shown below, option d cannot be formed as it does not connect the dots in the ascending order. Hence, the correct answer is option d.

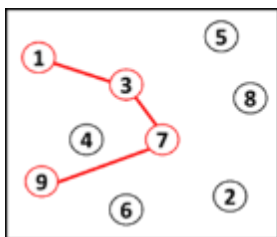

Option a
1-3-7-9
Ascending Order

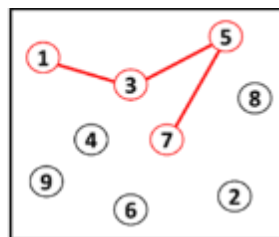

Option b
1-3-5-7
Ascending Order

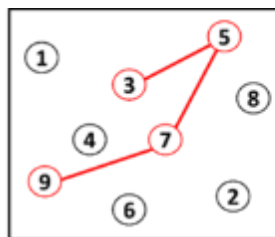

Option c
3-5-7-9
Ascending Order

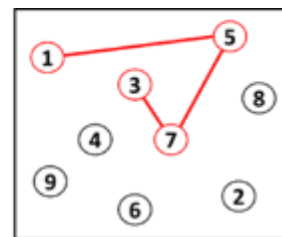

Option d
1-5-7-3
Not in
Ascending Order

11. Question: Is $M = N$?

Statement 1: N is an even number.

Statement 2: M is an odd number.

To answer the given question, which of the given statements is/are sufficient?

- a) Only 1
- b) Only 2
- c) Both 1 and 2 together
- d) Question cannot be answered even if both statements are used

Answer: c

Solution:

From statement 1, we know that N is an even number. So, statement 1 alone is insufficient.

From statement 2, we know that M is an odd number. So, statement 2 alone is insufficient.

Now, if we use both statements together, N is even and M is odd, which means they can never be equal. So, the question can be answered if we use both the statements together.

Hence, option c is the correct answer.



The Thinking Spot

Given below is an arrangement of 6 circles, each filled with a different colour: Yellow, Black, Purple, Red, Blue, and Green.

- The Yellow circle is connected to all circles except the Black circle
- The Black circle is only connected to the Purple circle
- The Yellow circle is the only circle that is connected to the Red circle
- The Blue circle is directly connected to the Yellow circle and to only one other circle

What is the colour of the circle marked with "?"

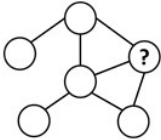

(a) Red

(b) Purple

(c) Green

(d) Blue

Answer: c

Solution:

The correct approach to solve this question is to analyse each statement one by one and assign the circles accordingly.

- The Yellow circle is connected to all circles except the Black circle
- To identify the correct circle, we need to find the one that is connected to all others except one
- Once identified, we can highlight it and proceed with the remaining connections

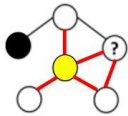

The Black circle is only connected to the Purple circle. So, we need to find the circle that is connected to the Black circle and assign it accordingly.

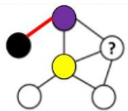

The Yellow circle is the only circle connected to the Red circle. Now, we need to identify a circle that is only connected to the Yellow circle and assign it accordingly.

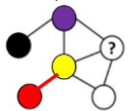

The Blue circle is directly connected to the Yellow circle and to only one other circle. Now, among the remaining two circles, we need to select the one that is connected to exactly two circles, with one of them being the Yellow circle.



Hence, the colour of the circle which is marked with "?" is Green.

Hence, the correct answer is option c.



Chapter 4: Thousands Around Us

Activity: Sorting Network

Introduction

Ever wondered how computers sort random things into order so quickly? Books in library, dictionaries, list of students in the classroom, are arranged in an order for convenience. Without sorting, finding information would be much more difficult. This activity uses the network template to be drawn on a floor using chalk (or use flex print) and demonstrates how the numbers can be arranged in order.

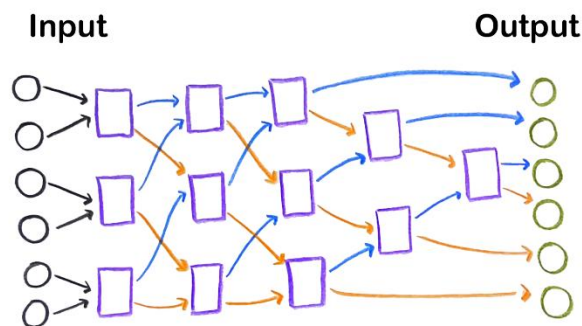
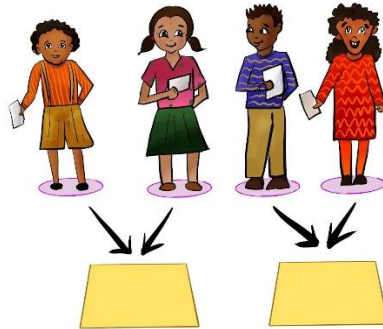

Activity	Time	Description
Launch	15-20 mins	<p>Teacher will take the students to outdoor and conduct the activity.</p> <p>Supporting Links:</p> <ul style="list-style-type: none"> • Network template - https://tinyurl.com/SortingNetworkCT • Activity Video Link - https://tinyurl.com/SortingNetworkVideo • Reference - https://www.csunplugged.org/en/topics/sorting-networks/

Trials by Students	10 min	Student's try out the activity within a batch of 6. Others can observe the activity and take turns to try out.
Discussions and Explorations	15 min	Attempting the worksheets and the discussion based on the activity

Computational Thinking Components

- *Sorting Algorithm*: The network sorts any given set of numbers in an ordered list. The design of the network and related tasks provides opportunity to think about the logic and algorithm behind the activity.
- *Abstraction*: The design of the network is an abstract representation of how actually data is organised into computer.
- *Decomposition*: The network can be started with comparing two numbers and repeating that basic comparison unit, we can sort any set of input numbers.

Explorations

Explore the activity with different orders of the numbers in the starting position. Are numbers getting sorted at the end for every input sequence? Instead of numbers 1 to 6, take 2-digit and 3-digit numbers. For example: {23, 56, 78, 113, 378, 667}.

Similarly, the same activity can also be done for sorting students with their names in an alphabetical order. Students will ask each other's name in the comparison box. The one with prior in order will go to left, the other one to the right. See if the names are in order at the end or not at the end. Try the same activity by comparing their height.

Consider the network to sort any 4 input numbers. The input numbers are {78, 56, 23, 113}. From the input circle position, move the numbers forward to the rectangle box and compare them. The smaller number will follow the blue line and bigger will follow the orange line.

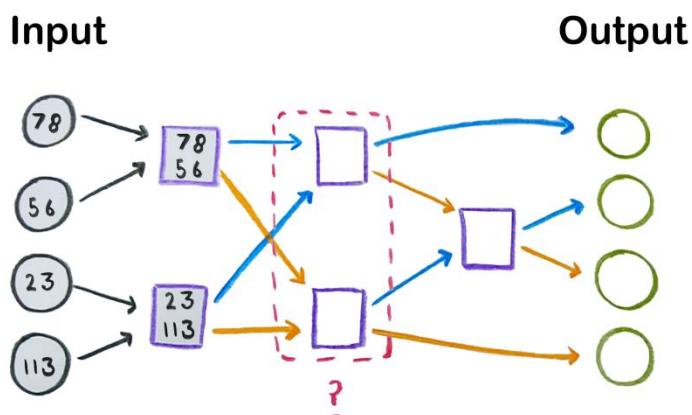

1. What will be correct positions of input numbers after the first level of comparison?

Input Output

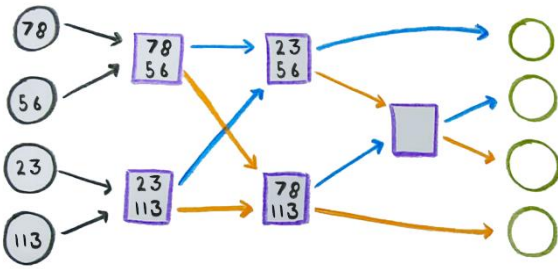

a)

Input Output

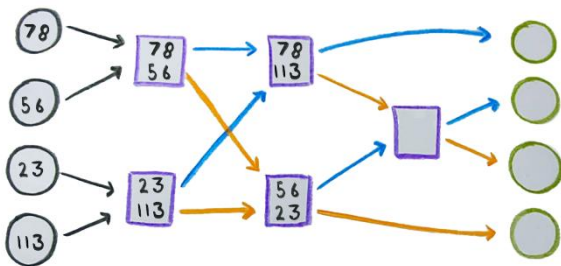

b)

Answer: a

Solution:

The smaller number moves along the blue line.

2. What will be correct positions of input numbers after the second level of comparison?

Input Output

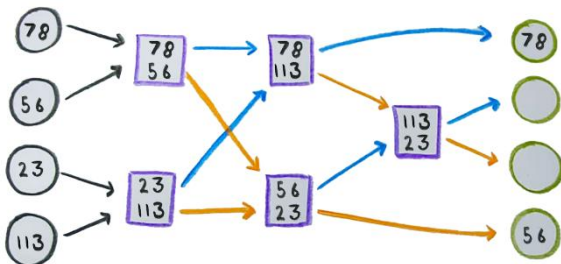

a)

Input Output

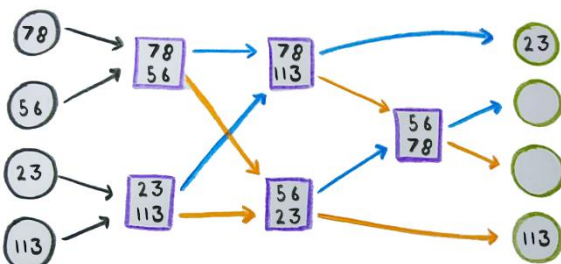

b)

Answer: b

Solution:

By following orange line from the upper box, 56 will reach the comparison box. By following the blue line from the lower box, 78, will reach the comparison box.

Now consider the reversal in the rule. Instead of the smaller number following the blue, now, the bigger number from the comparison box will follow the blue arrow. The smaller number will follow the orange arrow.

3. What will be the output order of the numbers at the end, if the comparison box rule is reversed?

- a) No difference, output will be same
- b) Output numbers will be in reverse order - descending
- c) The output depends on input number order
- d) Can't say anything about the order

Answer: b**Solution:**

At every comparison, the bigger number will follow the blue line and move upwards while smaller number will follow the orange line and move downwards.

Questions

1. **15A9 and 1A79 are two 4-digit numbers where A represents one of their digits. Which of these conditions about these 4-digit numbers CAN be true, when A is less than 6?**

a) $15A9 > 1A79$ b) $15A9 < 1A79$ c) $15A9 = 1A79$ d) Either A or B

Answer: d

Solution:

The numbers given are 15A9 and 1A79

Step 1: Compare place values

Both numbers are 4-digit numbers, so we compare the digits from left to right.

Thousands place: Both have 1 in the thousands place.

Step 2: Hundreds place: We have A and 5 in hundreds place.

A is less than 6.

A can be 5, 4, 3, 2, 1 or 0.

If $A = 5$, then $1559 < 1579$.

If $A < 5$, say 4, then $1549 > 1479$.

So, for $A = 5$, option b is true and for any other value less than 5, option a can be true.

Hence, option d is the correct answer.

-
2. **What is the smallest possible 4-digit number formed using 4 different circles from the grid given below, such that the number of white circles in the number formed is less than that of the black circles?**



a) 1360 b) 1023 c) 1063 d) 1036

Answer: d

Solution:

The number of black circles in the 4-digit number formed must be more than the white circles.

As the grid has only 3 black circles, the number of black and white circles used in the 4-digit number must be 3 and 1 respectively.

The black circles contain the digits 6, 3, and 1.

Among the white circles, 0 must be used to minimize our number.

So, the smallest possible 4-digit number that can be formed is 1036.

Option d is correct.

-
3. **In the given expression, 56B1 and 5B60 represent two 4-digit numbers, where "B" represents one of the digits. How many DIFFERENT VALUES can "B" take from SET B to satisfy the given condition?**

$$56B1 > 5B60$$

1, 3, 4, 6, 7, 8

SET B

a) 5 b) 4 c) 3 d) 2

Answer: b

Solution:

Step 1: Compare digits place by place

Thousands place: Both numbers have 5 thus they are equal.

Hundreds place: Compare 6 (in 56B1) with B (in 5B60).

For $56B1 > 5B60$, the hundreds digit of the first number (6) must be greater than the hundreds digit of the second number (B).

That means:

$$6 > B$$

If we put B as 6,

$5661 > 5660$, it also satisfies the condition.

Hence B can be less than or equal to 6.

There are 4 numbers in SET B which are less than or equal to 6

Therefore, option b is correct.

4. Using the digits 4, 8, 7, 6, 1, 3, and 5, form the largest and the smallest 4-digit numbers such that no digit repeats within a number. Which digit will be common in both numbers?

a) 3

b) 4

c) 5

d) 6

Answer: c

Solution:

To create the largest and the smallest 4-digit numbers using the digits 4, 8, 7, 6, 1, 3, and 5 ensuring that each digit is unique within a number, we can arrange them accordingly.

The largest 4-digit number:

Arrange the larger digits in descending order: 8765

The smallest 4-digit number:

Arrange the smaller digits in ascending order: 1345

Now, between 8765 and 1345, we can observe that both numbers share the digit 5.

Option c is correct.

5. If you remove the digit that is common to all four numbers shown below, which number will become the largest?

Note: You cannot re-arrange the digits to form a number

49526	21724	68401	64851
-------	-------	-------	-------

Number 1

Number 2

Number 3

Number 4

a) Number 1

b) Number 2

c) Number 3

d) Number 4

Answer: a

Solution:

Step 1: Find the digit common to all four numbers

Check digits present in each:

49526: {4, 9, 5, 2, 6}

21724: {2, 1, 7, 2, 4}

68401: {6, 8, 4, 0, 1}

64851: {6, 4, 8, 5, 1}

The digit 4 appears in every number. So, we must remove 4 from each.

Step 2: Remove the digit 4 (without rearranging)

Number 1: 49526. Remove 4 = 9526

Number 2: 21724. Remove 4 = 2172

Number 3: 68401. Remove 4 = 6801

Number 4: 64851. Remove 4 = 6851

Step 3: Compare the resulting numbers

9526 (Number 1)

2172 (Number 2)

6801 (Number 3)

6851 (Number 4)

The largest value is 9526 (Number 1).

Therefore, option a is correct.

6. Which of the following numbers can come in place of "#" in the given expression?

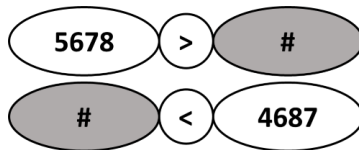

a) 5321

b) 6489

c) 4897

d) 4678

Answer: d

Solution:

Write down the condition clearly

$$5678 > \# < 4687$$

This means '#' must be smaller than both 5678 and 4687.

So, $\# < 4687$ is the stronger condition to satisfy.

From the given options, only 4678 satisfies both inequalities.

Therefore, option d is correct.

7. How many numbers from Set A can be placed in the blank, to form a number greater than 6632?

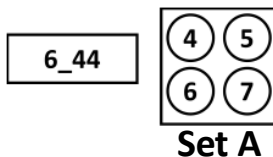

a) 1

b) 2

c) 3

d) 4

Answer: b

Solution:

Given: Number formed = 6_44

Set A = {4, 5, 6, 7}

We need to find how many numbers from Set A can be placed in the blank so that the number formed is greater than 6632.

Numbers greater than 6632: 6644 and 6744

Therefore, option b is correct.

8. If you add ALL the digits in the HUNDREDS place of the numbers given below, what will be the digit in the TENS place of the resulting number?



a) 1

b) 2

c) 3

d) 0

Answer: b

Solution:

Step 1: Identify the digits in the HUNDREDS place of the given numbers

In 5432, hundreds digit = 4

In 2879, hundreds digit = 8

In 1945, hundreds digit = 9

Step 2: Add these digits

$$4 + 8 + 9 = 21$$

Step 3: Find the digit in the TENS place of 21

The tens digit in 21 is 2.

Therefore, option b is correct.

9. How many numbers in Box A, after swapping their tens and thousands digits, will be less than 3000?

Box A

3425	5647
7423	8851

a) 4

b) 3

c) 2

d) 1

Answer: c

Solution:

Identify the thousands and tens digits.

Let's write each number in the form:

(Thousands) (Hundreds) (Tens) (Ones)

Number	Thousands	Hundreds	Tens	Ones
3425	3	4	2	5
5647	5	6	4	7
7423	7	4	2	3
8851	8	8	5	1

Swap the thousands and tens digits.

We interchange the 1st (thousands) and 3rd (tens) digits in each number.

Original	After Swap (Thousands ↔ Tens)	New Number
3425	2435	2435
5647	4657	4657
7423	2473	2473
8851	5881	5881

Check which numbers are less than 3000.

Now we compare each new number with 3000:

$$2435 < 3000$$

$$4657 > 3000$$

$$2473 < 3000$$

$$5881 > 3000$$

There are **2 numbers** (2435 and 2473) that are less than 3000.

Therefore, option c is correct.

10. How many numbers from "Image A" can be placed in BOTH the boxes given below?

Image A

4856, 4674, 4775, 4326, 4436, 4563, 4653, 4532

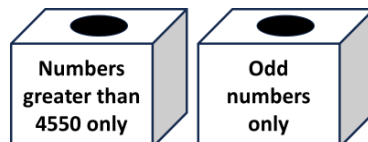

a) 2

b) 3

c) 4

d) 5

Answer: b

Solution:

Step 1: Filter for numbers greater than 4550

Compare each number with 4550:

4856 > 4550, keep
4674 > 4550, keep
4775 > 4550, keep
4326 < 4550, exclude
4436 < 4550, exclude
4563 > 4550, keep
4653 > 4550, keep
4532 < 4550, exclude

So, the numbers remaining after this filter are: 4856, 4674, 4775, 4563, and 4653.

Step 2: From these, keep only odd numbers

A number is odd if its last digit is odd (1,3,5,7,9).

Check the last digit of each number:

4856: last digit 6 is even. exclude

4674: last digit 4 is even. exclude

4775: last digit 5 is odd. keep

4563: last digit 3 is odd. keep

4653: last digit 3 is odd. keep

The numbers that satisfy both conditions are: 4775, 4563, and 4653.

Therefore, option b is correct.



The Thinking Spot

A, B, and C want to meet. They cannot meet in the boxes they are currently standing in or in any boxes immediately connected to them. In how many boxes can they meet?

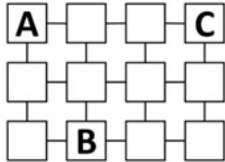

- (a) 1 (b) 2 (c) 3 (d) 4

Answer: b

Solution:

A, B, and C cannot meet in any of the boxes that are immediately connected to them.

So, the first step is to cancel out the boxes that are immediately next to A.

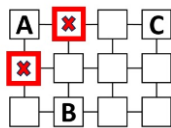

Next, cancel out the boxes that are immediately next to B.

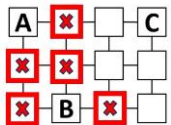

Now, cancel out the boxes that are immediately next to C.

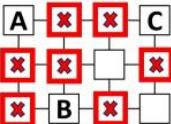

So, there are 2 boxes where A, B, and C can meet, as highlighted below:

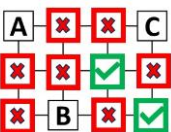

Hence, the correct answer is option b.



Chapter 5: Sharing and Measuring

1. How many bottles in the image below are filled to less than half their capacity?



- a) 2 b) 3 c) 4 d) 5

Answer: c

Solution:

As shown below, there are 4 bottles in which less than half of the portion is filled. Hence, the correct answer is option c.

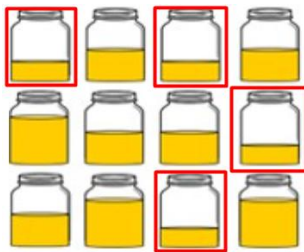

2. What fraction of the given image is shaded grey?

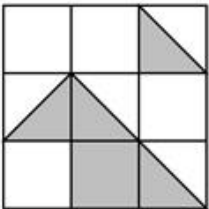

- a) $5/18$ b) $5/9$ c) $6/18$ d) $7/9$

Answer: c

Solution:

As shown in the figure below, if we divide each square into 2 triangles, then there are altogether 18 triangles, out of which 6 are shaded grey. Thus, **$6/18$ of the shape is shaded grey.**

Hence, the correct answer is option c.

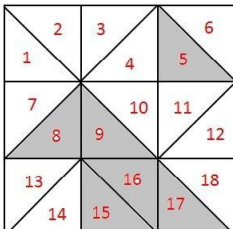

3. Diksha bought some pens for exactly Rs. 80. If each pen costs the same, which of the following **CANNOT** be the price of a pen?

- a) Rs. 4 b) Rs. 5 c) Rs. 6 d) Rs. 8

Answer: c

Solution:

Diksha bought some pens for Rs. 80. The price of all the pens is equal.

Option a: $80 \div 4 = 20$ (20 pens can be bought)

Option b: $80 \div 5 = 16$ (16 pens can be bought)

Option c: $80 \div 6 = 13.33$ (we cannot buy pens in fractions)

Option d: $80 \div 8 = 10$ (10 pens can be bought)

Hence, the price of a pen cannot be Rs. 6. Therefore, the correct answer is option c.

4. What will come in place of "?" in the given series?



Answer: a

Solution:

The series follows two rules:

1. Each time, the smaller (inner) circle increases by a quarter portion (in anti-clockwise order).
2. The bigger (outer) circle decreases by a quarter portion (in clockwise order).

From the 1st to the 3rd figure, the inner circle increases from $\frac{1}{4}$ to $\frac{1}{2}$ to $\frac{3}{4}$, while the outer circle loses one quarter each time.

So, in the next figure:

- The inner circle becomes complete
- The outer circle appears as a quarter

Only option a matches this.

Hence, the correct answer is option a.

5. Which of the following options shows the correct number of minutes in $(\frac{1}{4} + \frac{1}{2})$ hour?

a) 5×8 minutes

b) $60 - 10$ minutes

c) $21 + 24$ minutes

d) 3×10 minutes

Answer: c

Solution:

We know that 1 hour = 60 minutes.

So, $\frac{1}{4}$ of an hour = $60 \div 4 = 15$ minutes and

$\frac{1}{2}$ of an hour = 30 minutes

So, $30 + 15 = 45$ minutes

Now check each option:

- $5 \times 8 = 40$ minutes
- $60 - 10 = 50$ minutes
- $21 + 24 = 45$ minutes. This is equal to $(\frac{1}{4} + \frac{1}{2})$ hour.
- $3 \times 10 = 30$ minutes

Therefore, option c is correct.

6. Find the ODD one out.



a)



b)



c)

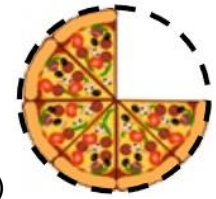

d)

Answer: d

Solution:

All the other options have half a pizza, except option d, which has three-quarters of a pizza. Hence, the correct answer is option d.

7. If each of the given terms follows the same theme, what will come in place of "?"

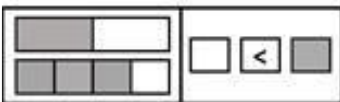
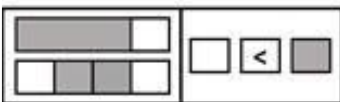
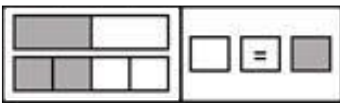

a) =

b) >

c) <

d) None of these

Answer: a

Solution:

In each row, the left box contains two horizontal bars, a top bar and a bottom bar.

Each bar is divided into parts, some shaded and some white.

To decide the symbol on the right side, we must consider the total shaded and total white parts together from both bars.

Observe the given rows:

First row:

The total shaded area (top + bottom) is equal to the total white area.

So, the symbol shown is "=".

Based on the same rule, in the last row, when we count the top and bottom bars together, the total shaded area and the total white area are equal.

So, the correct symbol should be "=".

Hence, the correct answer is option a.

8. What will come in place of "?"

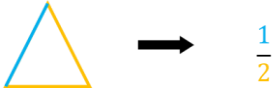
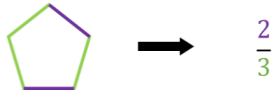
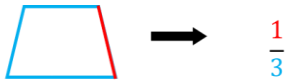

a) $\frac{2}{4}$

b) $\frac{2}{5}$

c) $\frac{2}{4}$

d) $\frac{2}{5}$

Answer: a

Solution:

We observe that in each given figure, a fraction represents the number of sides of two different colours. The numerator and denominator are also shown in the colour corresponding to the edges.

The smaller number is written as the numerator. For example, in the first term, one edge is red and the other three are blue. Therefore, the resulting fraction is $\frac{1}{3}$, where 1 is shown in red and 3 in blue.

Here, we have 2 edges in purple and 4 edges in pink.

Hence, the answer should be $\frac{2}{4}$, where 2 must be in purple colour and 4 in pink colour.

Hence, option a is correct.

9. A piece of paper is shaped like a rhombus, but not a square. At most, how many times can it be folded so that each fold divides it into two identical halves?

a) 0

b) 1

c) 2

d) 3

Answer: c

Solution:

The given paper is a rhombus, but not a square.

First fold:

The paper can be folded exactly into two equal parts along the diagonal BD. Both sides match perfectly.

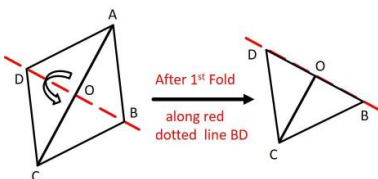

Second fold:

The folded paper can again be folded into two equal parts along line OC, as shown in the figure.

After the second fold, the paper becomes a triangle with unequal sides.

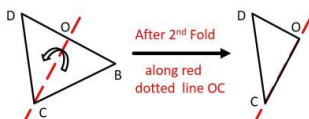

In this shape:

- There is no way to fold the paper so that both parts match exactly
- No folding line divides the figure into two identical parts



This figure cannot be folded into half

So, the paper cannot be folded into equal halves anymore.
The rhombus can be folded into identical halves at most 2 times.
Hence, the correct answer is option c.

10. What will come in place of "?"

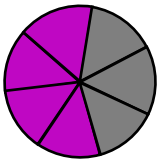
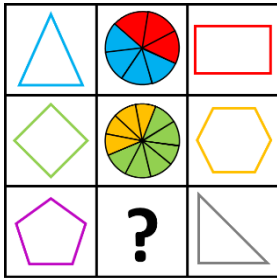

a)

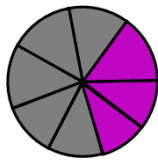

b)

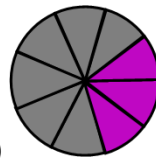

c)

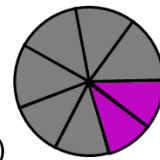

d)

Answer: b

Solution:

Observed pattern

Number of parts:

The circle in the middle is divided into as many parts as the **total number of sides** of the two shapes on its left and right.

Colours used:

The parts of the circle are coloured using the **same two colours** that appear on the adjacent shapes.

Colour distribution (opposite mapping):

Within a row, the parts of the circle are filled using the **opposite colour pattern** of the two adjacent shapes.

For example, in Row 1 the triangle has **3 blue sides**, and the rectangle has **4 red sides**.

So, the circle's parts representing the triangle are coloured **red**, and the parts representing the rectangle are coloured **blue**.

Applying the rule to Row 3

- The two shapes in Row 3 together have **8 sides** in total
- Therefore, the circle should be divided into **8 parts**
- Following the opposite-colour rule, **3 parts** should be coloured **purple**, and **5 parts** should be coloured **grey**

Hence, the correct answer is option b.



The Thinking Spot

At a party, there are 10 people. Each person at the party knows at least one other person there. Which of the following statements can never be true?

Note: *If A knows B, then it does not necessarily mean that B knows A*

- (a) Every person knows only one other person
- (b) Every person knows all the other people
- (c) Every person knows a different number of people
- (d) Every person knows exactly two other people

Answer: c

Solution:

There are 10 people at the party.

Each person knows at least one other person. So, each person can know 1, 2, 3, 4, 5, 6, 7, 8, or 9 people. Now, let's check the options.

Option a: Every person knows only one other person

This is possible. Each person can know just one person. So, this can happen.

Option b: Every person knows all the other people

Each person would know 9 people. This is also possible.

Option c: Every person knows a different number of people

The possible numbers are 1 to 9. But there are 10 people.

Since there are only 9 different numbers, two people must have the same number.

So, it is not possible for all 10 people to have different numbers.

Option d: Every person knows exactly two other people

This is also possible.

Therefore, the statement that can never be true is: Every person knows a different number of people.

Hence, the correct answer is option c.



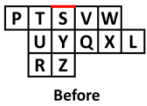

Before

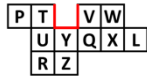

After

If we remove Block R, two sides are removed, and 2 sides are added. Therefore, the perimeter remains the same.

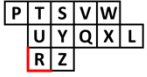

Before

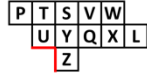

After

If we remove Block P, three sides are removed, and one side is added. Therefore, the perimeter decreases.

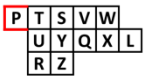

Before

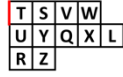

After

Hence, option d is the answer.

3. Every coloured line represents a path and through this path the boy on the LEFT can reach the RIGHT side. If he chooses the shortest path, how many junctions will he come across?

Note: A junction is the point where any two coloured lines cross each other

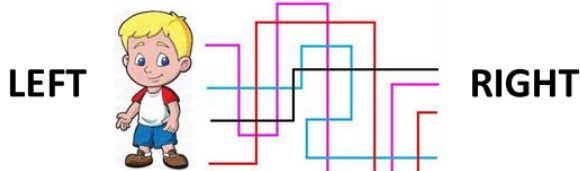

- a) 6
- b) 7
- c) 8
- d) 9

Answer: c

Solution:

The shortest way is the black one. If he goes this way, he will come across 8 junctions. Hence, the correct answer is option c.

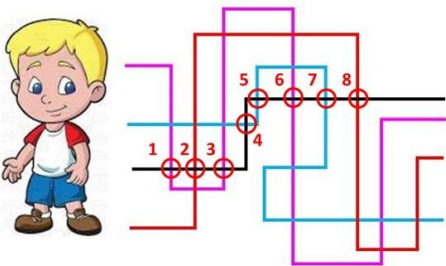

4. Count the number of blocks that have ALL THREE lines of different lengths.

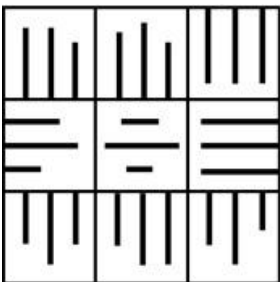

- a) 3
- b) 4
- c) 5
- d) 6

Answer: b

Solution:

There are 4 blocks with ALL THREE lines of different lengths.

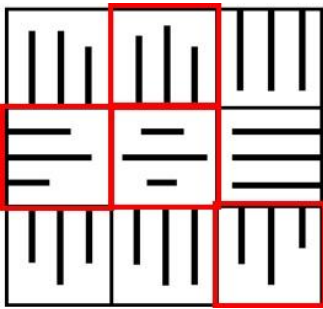

Hence, the correct answer is option b.

5. Given below are lines of different lengths. They are to be categorized into three groups based on their lengths:

- Group 1 for lines taller than line E
- Group 2 for lines shorter than line D
- Group 3 for lines taller than line B

Which line will belong to all three groups?



a) A

b) F

c) C

d) D

Answer: a

Solution:

Identifying lines based on their height:

Group 1 includes lines taller than E:

A, B, C, D, F, H

Group 2 consists of lines shorter than D:

A, B, E, G, H

Group 3 comprises lines taller than B:

A, C, D, F

Line A is present in all three groups. Thus, option a is the correct answer.

6. In the set of bars given below, which bar does NOT have any other bar of the SAME height?

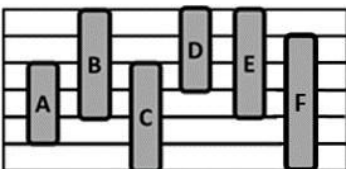

a) Bar E

b) Bar D

c) Bar C

d) Bar F

Answer: d

Solution:

Bars A and D are of the same height, as shown in the image.

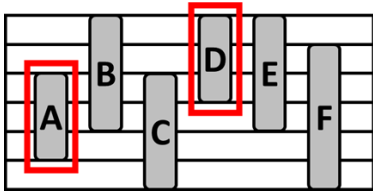

Bars B, C, and E are of the same height, as shown in the image below.

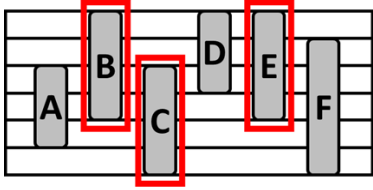

Only Bar F does not have any other bar of the same height. Option d is the correct answer.

7. Which option will come in place of "?"

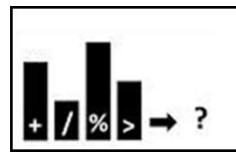
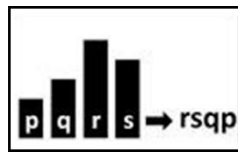
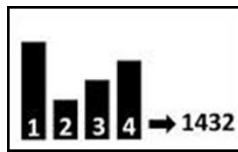
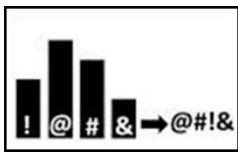

a) % + / >

b) / % + >

c) % > + /

d) % + > /

Answer: d

Solution:

Each bar has a symbol inside it. After the arrow, the symbols are arranged from the tallest bar to the shortest bar.

The same rule is followed throughout.

Applying this rule to the last set, arranging the symbols from highest bar to lowest bar gives:

% + > /

Hence, option d is the correct answer.

8. Each of the dogs A, B, and C use the red, yellow, and pink paths (in the same order), to go to their bone. If each dog takes 10 minutes to reach the bone, which dog runs the fastest?

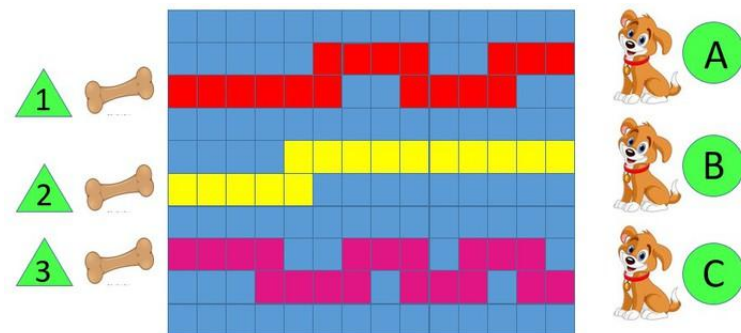

a) Dog A

c) Dog C

b) Dog B

d) Cannot be determined

Answer: c

Solution:

Since each dog takes 10 minutes to reach the bone, we need to count the number of blocks each of them is travelling. Therefore, Dog A has to travel 17 blocks, Dog B has to travel 15 blocks, and Dog C has to travel 19 blocks. Since Dog C is able to cover more blocks in the same time, Dog C is the fastest.

Hence, the correct answer is option c.

9. If the monkey follows the shortest path to reach the banana, which of the following options represents the tiles that will appear immediately one after another on its path? The tiles must appear in the same **SEQUENCE** as they appear in the original path.

Note: The monkey can move only horizontally or vertically along the tiles, not diagonally

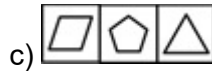
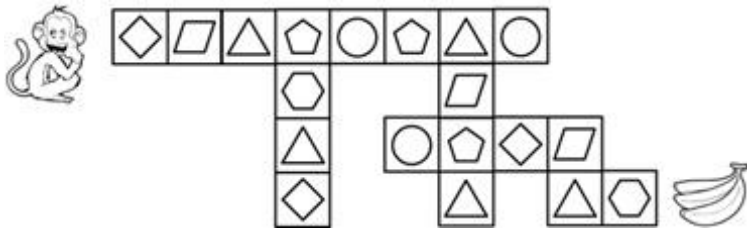

Answer: d

Solution:

The shortest path to reach the banana is shown below.

As can be seen, the tiles in option d appear consecutively on the monkey's path.

Hence, option d is the correct answer.

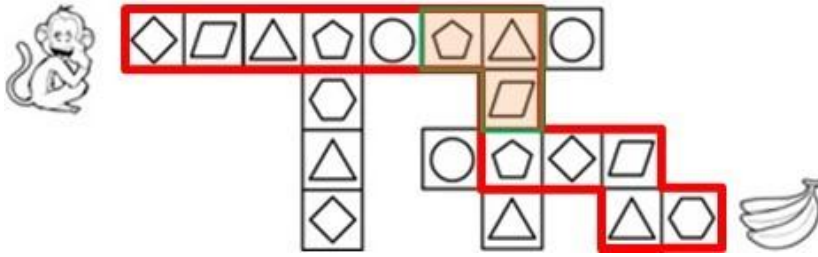

10. The cube shown below is cut horizontally along the red dotted line into two **EQUAL** halves. In each resulting shape, how many faces will still have the same perimeter as a face of the original cube?

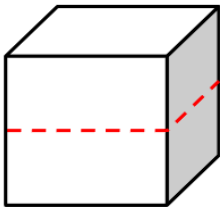

a) 1

b) 2

c) 4

d) 6

Answer: b

Solution:

Let the length of each face of the original cube be 'a'.

We know that the face of a cube is in the form of a square.

So, the perimeter of each face of the original cube = $a + a + a + a = 4a$.

Now, the cube is cut into two halves horizontally.

This means that the height of the original cube decreases.

The height becomes $a/2$.

Chapter 7: The Cleanest Village

1. A and B have Rs. 200 each. Each of them visited a shop and bought an item. A spent Rs. 110 more than B. What could be the highest possible amount spent by B?

- a) Rs. 200 b) Rs. 180 c) Rs. 100 d) Rs. 90

Answer: d

Solution:

Given that A and B have Rs. 200 each.

A spent Rs. 110 more than B.

The maximum amount that B can spend:

$$= 200 - 110 = 90.$$

If B spends more than Rs. 90, then, the amount spent by A would be 110 plus the amount spent by B.

This exceeds Rs. 200, which is contradictory, as A has Rs. 200 only.

Hence, option d, Rs. 90 is the highest possible amount spent by B.

2. The monkey starts at 0 points and needs to climb the staircase to the END. On each step, it either gains or loses points. Which ONE step must the monkey SKIP to earn exactly 114 points in total?

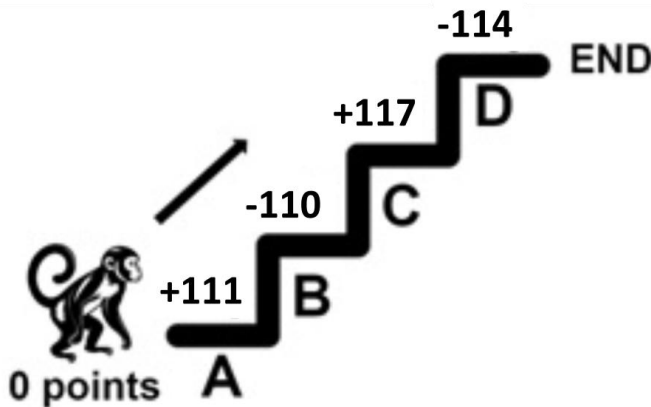

- a) A b) B c) C d) D

Answer: b

Solution:

The monkey starts with 0 points and must end with exactly 114 points.

There are four steps: A, B, C, and D. Each step either gives or takes away points.

The monkey must skip exactly ONE step.

Let's check each possibility one by one.

Step A (+111 points)

If the monkey skips Step A, the remaining points would come from B, C, and D only.

But Step A contributes a positive value (+111).

Skipping it makes it impossible to reach a total as large as 114.

So, Step A cannot be skipped.

Step B (-110 points)

If the monkey skips Step B, the total is:

- Step A: +111
- Step C: +117
- Step D: -114

$$\text{Total} = 111 + 117 - 114$$

$$\text{Total} = 114$$

This matches the required score.

Skipping Step B works.

Step C (+117 points)

If the monkey skips Step C, the total becomes:

- Step A: +111
- Step B: -110
- Step D: -114

$$\text{Total} = 111 - 110 - 114$$

$$\text{Total} = -113$$

This is not 114.

Skipping Step C does NOT work.

Step D (-114 points)

If the monkey skips Step D, the total becomes:

- Step A: +111
- Step B: -110
- Step C: +117

$$\text{Total} = 111 - 110 + 117$$

$$\text{Total} = 118$$

This is not 114.

Skipping Step D does NOT work.

The monkey must skip Step B to end with exactly 114 points.

Hence, the correct answer is option b.

-
3. Boxes A, B, and C each have 500 chocolates. Diya removed 222 chocolates from box B and 222 chocolates from box C. Nihal added 111 chocolates to box B, and Jay removed 111 chocolates from box A. Which boxes have an equal number of chocolates at the end?

- a) A and B
- b) A and C
- c) B and C
- d) No two boxes have the same number of chocolates

Answer: a

Solution:

A, B, and C have 500 chocolates each.

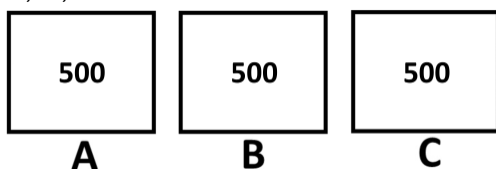

Diya removed 222 chocolates from boxes B and C each.

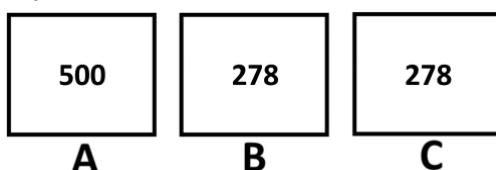

Nihal added 111 chocolates to box B.

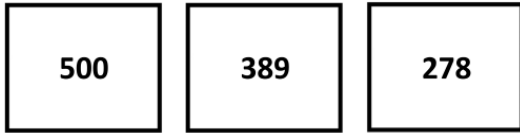

A **B** **C**

Jay removed 111 chocolates from box A.



A **B** **C**

Now, box A and box B have 389 chocolates each and box C has 278 chocolates.

Hence, the boxes that have an equal number of chocolates in the end are box A and box B.

Therefore, the correct answer is option a.

4. **A, B, and C represent 3 different single-digit numbers in the grid given below. If each of these options represents a 3-digit number formed using A, B, and C, find the option having the highest value.**

$$\boxed{4} + \boxed{A} = \boxed{5}$$

$$\boxed{7} - \boxed{B} = \boxed{C}$$

$$\boxed{C} + \boxed{5} = \boxed{8}$$

- a) BAC b) BCA c) CBA d) ABC

Answer: b

Solution:

First, let's solve for A:

From the equation:

$$4 + A = 5$$

So, $4 + 1 = 5$. Therefore, $A = 1$.

Now, let's solve for C:

$$C + 5 = 8$$

So, $3 + 5 = 8$. Therefore, $C = 3$.

Next, solve for B using the equation:

$$7 - B = C$$

$$7 - B = 3$$

So, $7 - 4 = 3$. Therefore, $B = 4$.

Now, we know the values:

- $A = 1$
- $B = 4$
- $C = 3$

Hence, the highest 3-digit number is: 431, which is BCA. Therefore, the correct answer is option b.

5. **Which of the following is the LEAST possible number that can replace the "?" such that the sum of the numbers in Row 2 is GREATER than the sum of the numbers in Row 1?**

Row 1 $\boxed{227}$ $\boxed{229}$ $\boxed{222}$

Row 2 $\boxed{?}$ $\boxed{228}$ $\boxed{227}$

- a) 221 b) 222 c) 223 d) 224

Answer: d

Solution:

The sum of the numbers in Row 1 is $227 + 229 + 222 = 678$.

To meet the condition, the sum of the numbers in Row 2 must be greater than 678. The numbers present in Row 2 (228 and 227) add up to $228 + 227 = 455$.

The difference between the sums of Row 1 and Row 2 is $678 - 455 = 223$.

Therefore, the number that should replace the question mark must be greater than 223. So, 224 is the least possible number among the options that fits the requirement.

Hence, the correct answer is option d.

6. What will come in place of "?"

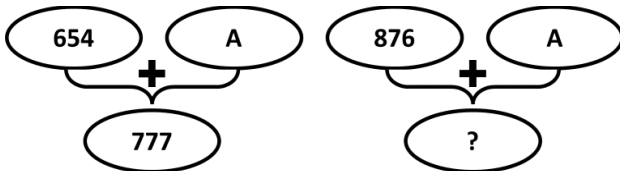

a) 970

b) 989

c) 999

d) 990

Answer: c

Solution:

$$654 + A = 777$$

$$\text{So, } 654 + 123 = 777$$

$$\text{Thus, } A = 123$$

$$\text{Now, } 876 + A = ?$$

$$876 + 123 = 999.$$

Hence, the answer is option c.

7. In a container, there are 20 blue balls and 13 red balls.

- On pressing Red button, 2 blue balls are removed
- On pressing Blue button, 2 red balls are removed
- On pressing Green button, 1 blue ball and 1 red ball are removed

If Sam presses the buttons in the following order, then which option shows the balls remaining in the container?

Red Button → Green Button → Blue Button → Green Button

a) 9 blue balls and 16 red balls

b) 16 blue balls and 9 red balls

c) 18 blue balls and 8 red balls

d) 16 blue balls and 10 red balls

Answer: b

Solution:

Since Sam has pressed the Red and Blue buttons once, two blue and two red balls will be removed.

Now, the Green button has been pressed twice.

So, 2 more red balls and 2 more blue balls will be removed.

So, in total, 4 red and 4 blue balls will be removed.

Hence, 16 blue balls and 9 red balls will be remaining.

Hence, the correct answer is option b.

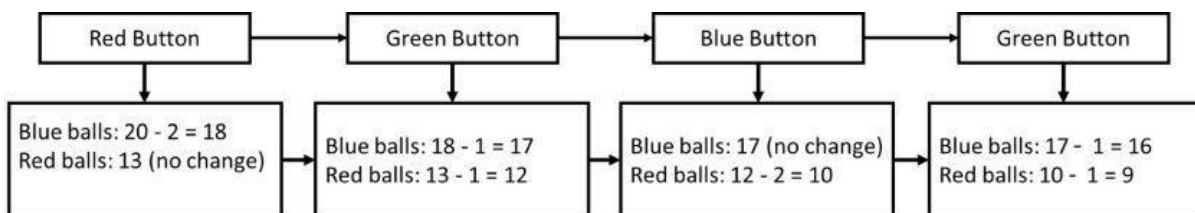

8. Which option represents the difference between the smallest and the largest possible 2-digit numbers (with both digits different) which you can form using the digits given below?

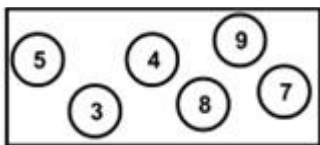

- a) 66 b) 64 c) 55 d) 98

Answer: b

Solution:

It is important to break it down into steps.

Step 1: Identify the two smallest numbers in the grid: 3 and 4. Place 3 in the tens place and 4 in the ones place to create the smallest 2-digit number: 34.

Step 2: Identify the two largest numbers in the grid: 8 and 9. Place 9 in the tens place and 8 in the ones place to create the largest 2-digit number: 98.

Step 3: Calculate the difference between the largest and the smallest numbers by subtracting 34 from 98, which equals 64.

Hence, the correct answer is option b.

9. If @ means addition (+) and # means subtraction (-), which of the following options will give the largest number?

- a) $434 @ 125 \# 236$ b) $443 @ 121 \# 234$ c) $457 \# 117 @ 233$ d) $441 @ 111 \# 50$

Answer: c

Solution:

We are given that:

- @ means addition (+)
- # means subtraction (-)

We need to evaluate each option and find which one produces the largest value.

Option a: $434 @ 125 \# 236$

Interpretation: $434 + 125 - 236$

- $434 + 125 = 559$
- $559 - 236 = 323$

Value of A = 323

Option b: $443 @ 121 \# 234$

Interpretation: $443 + 121 - 234$

- $443 + 121 = 564$
- $564 - 234 = 330$

Value of B = 330

Option c: $457 \# 117 @ 233$

Interpretation: $457 - 117 + 233$

- $457 - 117 = 340$
- $340 + 233 = 573$

Value of C = 573

Option d: $441 @ 111 \# 50$

Interpretation: $441 + 111 - 50$

- $441 + 111 = 552$
- $552 - 50 = 502$

Value of D = 502

Option c gives the largest number: 573.

Hence, the correct answer is option c.

10. What will come in place of "?"

$$2\ 6\ 1\ 3 \longrightarrow 8_7_4$$

$$3\ 2\ 6\ 3 \longrightarrow 5_8_9$$

$$1\ 8\ 1\ 7 \longrightarrow 9_9_8$$

$$4\ 5\ 0\ 7 \longrightarrow \quad ?$$

a) 5_0_7

b) 9_0_7

c) 9_7_7

d) 9_5_7

Answer: d

Solution:

In each row, the term after the arrow is the sum of pairs of adjacent digits of the 4-digit number given in the term before the arrow.

The sums are then separated by underscore signs.

For example, 2613 is written as $(2 + 6)_ (6 + 1)_ (1 + 3) = 8_7_4$.

Based on this logic, the last term can be written as: $(4 + 5)_ (5 + 0)_ (0 + 7) = 9_5_7$.

Hence, option d is the correct answer.



The Thinking Spot

If you colour all the shapes that are immediately next to a triangle on both sides, which shape will be coloured the maximum number of times?

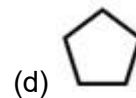
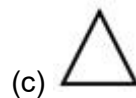
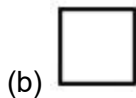
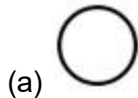

Answer: a

Solution:

The shapes that appear immediately next to a triangle on both sides are highlighted below:

- Square: 2 times
- Circle: 3 times
- Pentagon: 2 times

As we can see, the circle appears immediately next to a triangle 3 times, while the other shapes appear fewer times. Thus, the circle will be coloured the maximum number of times.

Hence, the correct answer is option a.



Chapter 8: Weigh It, Pour It

1. If the shapes given below represent weighing stones of different weights, which of the following options is definitely true?

$$\triangle = \circ + \square$$

$$\square = \circ + \circ$$

a) $\triangle > \circ > \square$

b) $\triangle < \circ < \square$

c) $\triangle > \square > \circ$

d) $\square > \triangle > \circ$

Answer: c

Solution:

We are given equations where different shapes represent different weighing stones. Our goal is to determine the definite relationship between the weights of the triangle (\triangle), circle (\circ), and square (\square).

Step 1: Understanding the First Equation

The first equation states:

Triangle = Circle + Square

This tells us that the triangle is heavier than both the circle and the square, since its weight is the sum of their weights.

Step 2: Understanding the Second Equation

The second equation states:

Square = Circle + Circle

This means the square is twice as heavy as the circle.

Step 3: Arranging the weights in Order

From equation 2:

- Since square = 2 × circle, it follows that the square is heavier than the circle.
- From equation 1: triangle = square + circle, which means triangle is the heaviest.

Thus, the final order of weights is:

Triangle > Square > Circle. Hence, the correct answer is option c.

2. In Figure A, the balance is equal and each shape has a different weight. Using this information, determine which option, when placed in place of the “?”, will balance the scale in Figure B.

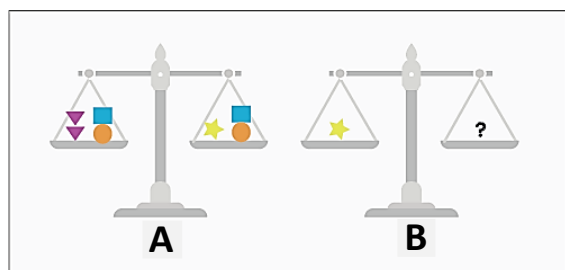

Answer: b

Solution:

It is mentioned that each shape has a different weight and in Figure A, the scale is balanced. This means both sides weigh the same. Now, notice that the blue square and the orange circle appear on both sides of the balance.

When the same objects are present on both sides, we can take them away from both sides without changing the balance.

After removing the blue square and the orange circle from both sides, the balance still stays equal.

It can be seen that:

- One star is equal in weight to two triangles

So, in Figure B, to balance the star, we must choose the object(s) that weigh the same as one star.

Two triangles weigh the same as one star. Hence, option b is the correct answer.

3. Which word should replace the question mark in circle B, such that every word in circle A has a word closely related to it in circle B?

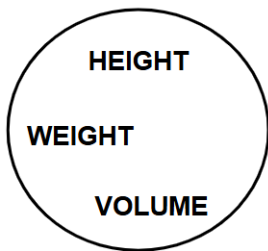

A

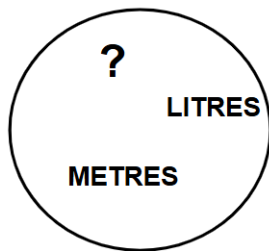

B

a) MINUTES

b) STONES

c) KILOGRAMS

d) BALANCE

Answer: c

Solution:

The units of the words present in circle A appear in circle B.

HEIGHT is measured in METRES, while VOLUME is measured in LITRES.

Similarly, WEIGHT is measured in KILOGRAMS.

Hence, option c is the answer.

4. A water cooler has 35 litres of water. There are two bags of empty bottles. One contains 5 bottles of 3 litre capacity each and the other contains 8 bottles of 5 litre capacity each. You have to empty the water cooler by filling in at least one bottle from each bag. When a bottle is picked, it must be filled completely. What is the MAXIMUM number of bottles that can be left empty, finally?



a) 6

b) 5

c) 4

d) 3

Answer: c

Solution:

Volume of water in the cooler = 35 litres.

There are two bags of bottles of different capacities:

5 bottles of 3 litre capacity each

8 bottles of 5 litre capacity each

Total number of bottles = $5 + 8 = 13$.

To maximize the number of empty bottles, we need to fill in more bottles having greater capacity.

Now, we can fill 7 bottles of 5L capacity, as $7 \times 5 = 35$.

In this case, $13 - 7 = 6$ bottles can be left empty.

However, as we need to fill in at least one bottle from each bag, the bottle with 3L capacity must be filled definitely.

When a bottle of 3L is filled, the remaining water in the cooler = $35 - 3 = 32$ L

But the other bag contains bottles of 5L capacity.

So, any quantity of the remaining water must be divisible by 5.

We have to fill in more 3L bottles to satisfy this condition.

There are altogether 5 bottles of 3L.

$3 \times 5 = 15$.

When we fill all 5 bottles, $35 - 15 = 20$ L of water is left, which is divisible by 5.

Then, from the other bag, 4 bottles of 5 litre capacity can be filled.

Let's cross-check:

5 bottles of 3L capacity: $5 \times 3 = 15$ litres

4 bottles of 5L capacity: $4 \times 5 = 20$ litres.

$15 + 20 = 35$

Thus, the total number of bottles filled = $5 + 4 = 9$

The total number of empty bottles = $13 - 9 = 4$

Hence, the correct answer is option c.

5. You have buckets of capacities 5 litres, 3 litres, and 1 litre. You may use any bucket more than once, but each type must be used at least once. What is the minimum number of buckets required to hold EXACTLY 20 litres of water?

Note: Each bucket must be filled completely



a) 4

b) 8

c) 7

d) 6

Answer: d

Solution:

The given bucket capacities are: 5 litres, 3 litres, and 1 litre. To minimise the total number of buckets used, we have to aim to use more buckets of maximum capacity.

As the maximum capacity is of 5 litres, we can use four buckets of 5 litres each, to measure 20 litres (as $5 \times 4 = 20$).

However, as per the question, all buckets must be used. (Here, 3-litre and 1-litre buckets are not used).

So, if three buckets of 5 litres are used (instead of 4), we can measure $3 \times 5 = 15$ litres.

The remaining 5 litres ($20 - 15 = 5$) can be measured using the other buckets as $3 + 1 + 1$.

So, to measure 20 litres, we must use three 5-litre buckets, one 3-litre bucket, and two 1-litre buckets.

Therefore, the minimum total number of buckets used = Three + One + Two = $3 + 1 + 2 = 6$.

Another possible arrangement of buckets holding 20 litres of water is:

$$5 + 5 + 3 + 3 + 3 + 1 = 20.$$

6 buckets are used in this arrangement as well.

Hence, the correct answer is option d.

6. A flight allows a passenger to carry a maximum of 20 kg of luggage. Johny already has a bag with him. He wants to find out the maximum additional weight he can carry (other than the bag), without crossing the limit. How can Johny calculate this?

- a) By adding the weight of bag to 20 kg
- b) By subtracting the weight of bag from 20 kg
- c) By multiplying the weight of bag to 20 kg
- d) None of these

Answer: b

Solution:

The plane allows a maximum of 20 kg of luggage.

This means the total weight of Johny's bag and any additional weight cannot be more than 20 kg.

So, Weight of bag + additional weight \leq 20 kg

To find out the maximum additional weight:

Maximum additional weight = 20 kg – weight of bag

Hence, option b is the correct answer.

7. Rheya weighs 18 kg less than her father. Her father weighs 10 kg more than her mother. If her mother's weight is 65 kg, find Rheya's weight.

- a) 57 kg
- b) 59 kg
- c) 47 kg
- d) 49 kg

Answer: a

Solution:

Rheya's mother's weight is 65 kg.

Rheya's father weighs 10 kg more than her mother.

So, $65 + 10 = 75$.

The weight of Rheya's father is 75 kg.

Rheya weighs 18 kg less than her father.

So, $75 - 18 = 57$.

Hence, the weight of Rheya is 57 kg.

Thus, option a is the correct answer.

8. Ravi's mother asked him to purchase 3 kg of mangoes and 2 kg of papaya. However, Ravi ended up buying 2 kg of mangoes and 3 kg of strawberry instead. How much extra money did he spend on fruits compared to his mother's list?

Fruits	Price(kg)
Apples	Rs. 50
Mangoes	Rs. 100
Strawberry	Rs. 150
Papaya	Rs. 170

- a) Rs. 10
- b) Rs. 20
- c) Rs. 40
- d) Rs. 50

Answer: a

Solution:

Cost of the fruits asked by Ravi's mother:

3 kg Mangoes = $3 \times 100 = \text{Rs. } 300$

2 kg Papaya = $2 \times 170 = \text{Rs. } 340$

Total cost = Rs. 640

Cost of the fruits bought by Ravi

2 kg Mangoes = $2 \times 100 = \text{Rs. } 200$

3 kg Strawberry = $3 \times 150 = \text{Rs. } 450$

Total = Rs. 650

So, the difference is $650 - 640 = \text{Rs. } 10$.

Hence, the correct answer is option a.

9. A is taller than B and heavier than C. C is taller than D and heavier than E. If a heavier person is always taller, then who is the tallest?

a) A

b) B

c) C

d) Cannot be Determined

Answer: a

Solution:

From the given information, in terms of height $A > B$ and $C > D$.

Also, A is heavier than C and C is heavier than E.

Since a heavier person is always taller, we have $A > C$ and $C > E$, which implies $A > C > E$.

Further, since $C > D$, A is taller than B, C, D, and E.

Hence, the correct answer is option a.

10. Twenty bottles are arranged from left to right in a single row. The position of a bottle from the left end of the row determines the quantity of water it contains. For example, the first bottle from the left has 1 L of water, the second bottle has 2 L, and so on. If the third bottle from the left is interchanged with the sixth bottle from the right, how many litres of water will finally be present in the first six bottles from the left?

a) 24 L

b) 27 L

c) 31 L

d) 33 L

Answer: d

Solution:

We have to determine the quantity of water in the 6th bottle from the right.

For this, we have to find its position from the left.

Total number of bottles = 20.

The 6th bottle from the right has 5 bottles to its right.

So, its position from the left = Total number of bottles - Number of bottles to its right

= $20 - 5$

= 15

Hence, the 6th bottle from the right is the 15th bottle from the left.

It has 15 L of water.

Now, when it interchanges its position with the 3rd bottle from the left, we will have the first 6 bottles as:

1, 2, 15, 4, 5, 6.

Therefore, the quantity of water present in the first 6 bottles from the left:

$1 + 2 + 15 + 4 + 5 + 6 = 33 \text{ L}$

Option d is the correct answer.



The Thinking Spot

For a six-faced dice with the numbers 1 to 6 written on its faces (one number on each face), which of the following statements can be definitely implied from the statement given below?

Statement: All numbers opposite to 2 are less than it.

- (a) 3 is written adjacent to 2
(b) 3 is written opposite to 2
(c) 4 is written opposite to 5
(d) None of these

Answer: a

Solution:

A face of a dice has four adjacent faces and one opposite face. Among the numbers 1 to 6, only 1 is smaller than 2. So, 1 must be opposite 2.

The remaining numbers: 3, 4, 5, and 6, are adjacent to 2.

Let us examine each option:

Option a: 3 is adjacent to 2, which is true.

Option b: 3 is opposite to 2, which is incorrect because 1 is opposite to 2.

Option c: It cannot be determined whether 4 is opposite to 5, as the face opposite 5 could be 3, 4, or 6.

Since only option a can be concluded from the given information, the correct answer is option a.



Chapter 9: Equal Groups

1. When 22 is added to a number, the resultant number is three times the number itself. What was the number?

- a) 11 b) 22 c) 33 d) 44

Answer: a

Solution:

Suppose the original number is 1.

If we add 2 to it, we get $1 + 2 = 3$, which is 3 times the original number.

This shows that when a number becomes 3 times, it has actually increased by 2 times its original value.

In the given question, this increase is 22.

So, 2 times of the original number = 22

Hence, 1 time (the original number) = 11

Therefore, the original number is 11. ($11 + 22 = 33$, and 33 is 3 times the original number)

Hence, option a is correct.

2. On a dice, different numbers are written on each face from 1 to 6 such that:

- 6 is adjacent to ALL the faces having odd numbers
- 2 is adjacent to ALL its multiples

How many DIFFERENT POSSIBLE numbers can be opposite to 1?

- a) 5 b) 2 c) 4 d) 3

Answer: d

Solution:

Let's assume that 6 is on the top face of the cube.

As per the conditions, 6 is adjacent to the faces having odd numbers.

So, 6 is adjacent to 1, 3, and 5. - - - (1)

Also, 2 is adjacent to ALL its multiples.

2 is adjacent to 4 and 6. - - - (2)

From 1 and 2, we can say that 6 is adjacent to 1, 2, 3, and 5.

6 is DEFINITELY OPPOSITE TO 4.

So, 4 can never be opposite to 1.

Also, 6 can never be opposite to 1.

Hence, only 2, 3, or 5 can be opposite to 1.

The correct answer is 3.

Hence, the correct answer is option d.

3. In a row of 50 boys, both Deepak and Mayank are positioned at multiples of 10 from the left end. Mayank's position is twice that of Deepak's position, and Deepak is not positioned at the 10th place from the left end. What will be Mayank's position from the right end?

- a) 10th b) 40th c) 11th d) 41st

Answer: c

Solution:

Step 1: Both Deepak and Mayank are at multiples of 10 from the left end.

So, possible positions for Deepak are 10, 20, 30, and 40.

Deepak cannot be at the 10th position (given).

If Deepak was at 30 or 40, then Mayank's position (which is double of Deepak's) would be 60 or 80, which is not possible in a row of only 50 boys.

So, the only possible position for Deepak is 20 from left end.

Step 2: Mayank's position will be twice that of Deepak's, which is $20 \times 2 = 40$.

Step 3: Mayank's position is 40 from the left. To find his position from the right, subtract the number of boys to his left from the total number of boys: $50 - 39 = 11$. So, Mayank's position is 11th from the right. Hence, the correct answer is option c.

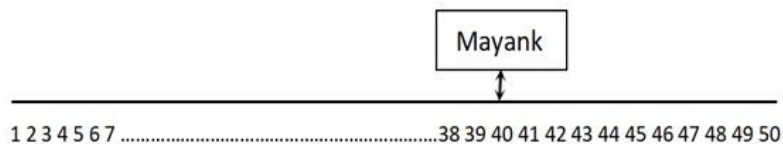

4. A sequence of numbers is given: 13, 26, 52, 104, 208. What would be the rule that is governing this sequence?

- a) Every term is 13 more than the previous term
- b) Every term is thrice the previous term
- c) Every term is two times the previous term
- d) Every term is 26 more than the previous term

Answer: c

Solution:

We observe that $13 \times 2 = 26$, $26 \times 2 = 52$, $52 \times 2 = 104$, and $104 \times 2 = 208$.

Hence, every term is twice the previous term. Hence, the correct answer is option c.

5. Radha has some five-rupee coins. Her friend Seeta asks how much money she has. What should Radha do to answer Seeta's question?

- a) Multiply the number of five-rupee coins she has with 2
- b) Multiply the number of five-rupee coins she has with 5
- c) Multiply the number of five-rupee coins she has with 0.5
- d) Multiply the number of five-rupee coins she has with 50

Answer: b

Solution:

Each coin amounts to five rupees. To calculate the amount of money, the number of coins should be multiplied by 5. Hence, the correct answer is option b.

6. In the middle of a round pool lies a beautiful water lily. The water lily doubles in size every day. After exactly 20 days, the lily will cover the complete pool. After how many days will the water lily cover half of the pool?

- a) 5
- b) 10
- c) 15
- d) 19

Answer: d

Solution:

On the 20th day, the water lily covers the entire pool.

Since the lily doubles in size every day, one day earlier it must have been half its size.

So, on the 19th day, the water lily covers half of the pool. Hence, the correct answer is option d.

7. I am a vehicle. To carry a group of 60 students, 8 vehicles like me are needed. To carry a group of 55 students, 7 vehicles like me are needed. How many students can I carry at most?

- a) 6
- b) 7
- c) 8
- d) 9

Answer: c

Solution:

To carry a group of 60 students, 8 vehicles like me are needed.

We know that $8 \times 7 = 56$, which is less than 60.

So, if 8 vehicles carry 7 students each, still 4 students will be left.

So, some of these vehicles must carry 8 students.

If the vehicle can carry more than 8 students, say 9, then $9 \times 7 = 63$.

7 vehicles are enough to accommodate 60 students.

8 vehicles are not necessary to carry 60 students, which is contradictory to the information given.

Similarly, as $7 \times 8 = 56$, to carry a group of 55 students, 7 vehicles like me are needed.

Hence, option c is the correct answer.

8. The number of sisters that Raj has is double the number of brothers he has. Raj does not have more than 5 brothers. At most, how many sisters will any sister of Raj have?

a) 6

b) 7

c) 8

d) 9

Answer: d

Solution:

If Raj has not more than 5 brothers, he can have a maximum of 5 brothers.

So, he can have a maximum of 10 sisters. So, a sister of Raj can have at most 9 sisters.

Please note that Raj will have 10 sisters. But one of Raj's sisters will have at most 9 sisters because she is one of the sisters.

Hence, the correct answer is option d.

9. If $A = 6$, Y is double of B , B is double of Z , and Z is double of A , which of the following expressions has the HIGHEST value?

a) $2 \times B - Z$

b) $3 \times Z + A$

c) $Y + Z - A$

d) $2 \times Y - B$

Answer: d

Solution:

First, find the values:

$$A = 6$$

$$Z = 2 \times 6 = 12$$

$$B = 2 \times 12 = 24$$

$$Y = 2 \times 24 = 48$$

Now evaluate each option:

$$\text{a) } 2 \times B - Z = 48 - 12 = 36$$

$$\text{b) } 3 \times Z + A = 36 + 6 = 42$$

$$\text{c) } Y + Z - A = 48 + 12 - 6 = 54$$

$$\text{d) } 2 \times Y - B = 96 - 24 = 72$$

Comparing the values:

36, 42, 54, 72

The HIGHEST value is 72, which comes from $2 \times Y - B$.

Hence, the correct answer is option d.

10. A square sheet has a side length of 10 cm. Among the options given below, how many equal-sized square sheets CANNOT be cut from this sheet such that no portion of the sheet remains?

a) 4

b) 9

c) 10

d) 16

Answer: c

Solution:

Actually, the given paper sheet can be divided into an infinite number of smaller equal sized squares.

To cut a big square into smaller equal squares without leaving any extra piece, we must divide the big square equally on both its sides.

This means the number of smaller squares we get will always be:

same number \times same number

For example:

- If we cut each side into 2 equal parts, we get $2 \times 2 = 4$ squares.
- If we cut each side into 3 equal parts, we get $3 \times 3 = 9$ squares.
- If we cut each side into 4 equal parts, we get $4 \times 4 = 16$ squares.

So, the total number of small squares must always be a number like:

$1 \times 1, 2 \times 2, 3 \times 3, 4 \times 4, 5 \times 5 \dots$ (these are called perfect squares).

Now look at the options given:

- $4 = 2 \times 2$ (possible)
- $9 = 3 \times 3$ (possible)
- $16 = 4 \times 4$ (possible)
- 10 cannot be written as same number \times same number. Thus, it is not possible.

There is no whole number that multiplies with itself to make 10.

So, we cannot cut the big square into 10 equal smaller squares.

Therefore, the answer is 10.

1	2
3	4

2 x 2 Squares

1	2	3
4	5	6
7	8	9

3 x 3 Squares

1	2	3	4
5	6	7	8
9	10	11	12
13	14	15	16

4 x 4 Squares

Hence, the correct answer is option c.



The Thinking Spot

If arrows can only travel straight in the direction they are pointing, then in how many empty cells can you place the balloon such that NO arrow can shoot it?

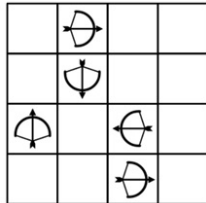

Balloon

(a) 2

(b) 3

(c) 4

(d) 5

Answer: c

Solution:

In order to find out the cells where the Balloon cannot be shot by any of the arrows, we cancel out all the cells that can be hit by the arrows, row by row.

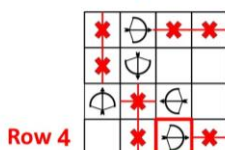
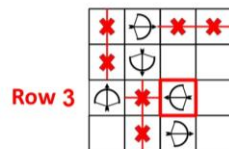
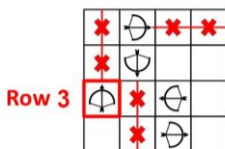
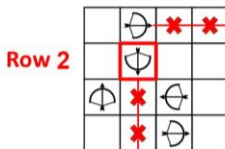
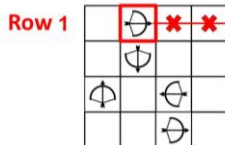

Hence, there are 4 cells where the balloon cannot be shot by the arrows, as highlighted below:

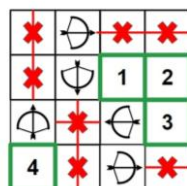

Hence, the correct answer is option c.



Chapter 10: Elephants, Tigers, and Leopards

1. There is a three-digit number. In this number, one odd digit occurs twice. The third digit is a sum of the digits occurring twice. What is the sum of all the digits?

- a) 4 or 12 b) 12 or 20 c) 20 or 28 d) 28 or 36

Answer: a

Solution:

Odd digits are: 1, 3, 5, 7, and 9

Now think carefully:

If the repeated odd digit is 5 or more, the third digit will be $5 + 5 = 10$ or more, which will make the number more than three digits (for example: 5, 5, and 10 cannot form a three-digit number).

So, only 1 and 3 can be used as the repeated odd digit.

If the repeated digit is 1, the third digit is 2

Sum of digits = $1 + 1 + 2 = 4$

If the repeated digit is 3, the third digit is 6

Sum of digits = $3 + 3 + 6 = 12$

So, the possible sums of the digits are 4 or 12.

Hence, the correct answer is option a.

2. Chris bought a notebook for ₹120, a compass box for ₹20 less than the notebook, and a water bottle for ₹80 more than the compass box. What is the total cost of all the three items?

- a) ₹380 b) ₹420 c) ₹400 d) ₹360

Answer: c

Solution:

Chris bought a notebook for ₹120.

A compass box for ₹20 less than the notebook. So, the cost of the compass box will be $120 - 20 = ₹100$.

A water bottle for ₹80 more than the compass box. So, the cost of a water bottle will be $100 + 80 = ₹180$.

So, the total cost of all the three items will be $120 + 100 + 180 = ₹400$

Hence, the correct answer is option c.

3. B has some money which could be in denominations of ₹10, ₹20, or ₹50. If B has four notes and only two types (denominations) of currency notes, then which of the following CANNOT be true regarding the amount of money B has?

- a) B has a total of 50 Rupees b) B has a total of 70 Rupees
c) B has a total of 90 Rupees d) B has a total of 110 Rupees

Answer: c

Solution:

B has 4 notes and must use only 2 types of denominations from ₹10, ₹20, and ₹50.

Let's check each option:

• Option a: 50 Rupees

A possible combination is:

$$20 + 10 + 10 + 10 = 50$$

(Uses only ₹10 and ₹20: valid)

• Option b: 70 Rupees

A possible combination is:

$$20 + 20 + 20 + 10 = 70$$

(Uses only ₹10 and ₹20: valid)

- Option d: 110 Rupees

A possible combination is:

$$50 + 20 + 20 + 20 = 110$$

(Uses only ₹20 and ₹50: valid)

- Option c: 90 Rupees

To make 90, ₹50 must be used (four ₹20 notes give only 80).

But, using ₹50 twice already gives 100 (too much) and using ₹50 once leaves 40, which can be made only with $20 + 20$ (3 notes total) or $10 + 10 + 10 + 10$ (needs 5 notes).

So, 90 cannot be formed using exactly 4 notes and only 2 denominations.

Option c cannot be true.

Hence, the correct answer is option c.

4. A, B, C, and D represent different digits in the 4-digit numbers given below. What will come in place of B and D?

$$\begin{array}{r} 5 B 2 3 \\ - A 6 9 C \\ \hline 4 1 D 9 \end{array}$$

a) $B = 7$ and $D = 2$

b) $B = 8$ and $D = 6$

c) $B = 8$ and $D = 2$

d) $B = 5$ and $D = 3$

Answer: c

Solution:

STEP 1: Starting from the unit's place, C must be a number greater than 3 that results in 9 as the answer and requires borrowing one ten. Therefore, C can be determined as follows: $13 - C = 9$.

Solving for C, we get $13 - 9 = 4$. Therefore, we find that C equals 4 (refer to image 1).

STEP 2: Moving to the tens place, we have 1 ten (we already borrowed 1 ten earlier) - 9 tens.

To make this subtraction work, we need to borrow one hundred from the left (reducing the value of B by 1), so it becomes $(11 - 9 = 2)$. Hence, we determine that D is equal to 2 (refer to image 2).

STEP 3: Now, we need to determine B. B must be a number such that when 7 hundred (1 hundred was borrowed, and 6 hundred are written below) are subtracted from it, the result is 1 hundred. This implies that B equals 8. Therefore, in this context, we can conclude that B is equal to 8 (refer to image 3).

Hence, the correct answer is option c.

$$\begin{array}{r} 1 13 \\ 5 B \cancel{2} \cancel{3} \\ - A 6 9 4 \\ \hline 4 1 D 9 \end{array}$$

Image 1

$$\begin{array}{r} 8 - 1 11 1 \\ 5 B 2 3 \\ - A 6 9 4 \\ \hline 4 1 2 9 \end{array}$$

Image 2

$$\begin{array}{r} 7 11 1 \\ 5 \cancel{8} 2 3 \\ - 1 6 9 4 \\ \hline 4 1 2 9 \end{array}$$

Image 3

5. Ram, Rohit, and Rohan are best friends, and each of them has some money. Ram has Rs. 10 more than Rohit, and Rohan has Rs. 10 less than Rohit. They decide to pool all their money and divide it equally. After the division, who gets more money than what he had before the division?

a) Ram

b) Rohit

c) Rohan

d) Cannot be determined

Answer: c

Solution:

Assume the three friends have the following amounts:

- Ram = ₹30
- Rohit = ₹20
- Rohan = ₹10

Total money = $30 + 20 + 10 = ₹60$.

If they divide this equally among the three, each gets $₹60 \div 3 = ₹20$.

Compare this with what each had before the division:

- Ram had ₹30 and now has ₹20. So, Ram gets less
- Rohit had ₹20 and now has ₹20. So, Rohit's amount stays the same
- Rohan had ₹10 and now has ₹20. So, Rohan gets more

So, Rohan (who initially had the least) ends up with more than what he had before.

Reasoning in general: In many problems, people put their money together and divide it equally.

The person who had the least money at the start will always gain something (or at least not lose).

This happens because the equal share is close to the average amount.

So, people who have less than the average will gain money.

Therefore, Rohan will get more than what he had before the division.

Hence, the correct answer is option c.

6. When the digits of a 3-digit number are reversed, the difference between the new number and the original number comes out to be zero. What is the minimum possible sum of the digits of the original number?

- a) 1 b) 2 c) 3 d) 4

Answer: b

Solution:

If the difference is 0 then the original 3-digit number and the number formed after reversing the digits must be the same.

So, this 3-digit number is in the form of YXY or YYY.

Suppose $Y = 1$ and $X = 0$. Then the number YXY becomes 101, and YYY becomes 111.

Since we want the minimum possible sum of digits, the middle digit should be 0.

Therefore, we choose the three-digit number of the form YXY.

Now, if we want the minimum possible sum, we have to choose the minimum possible values of X and Y which can be 0 and 1 respectively.

So, the number formed would be 101.

The sum of the digits of this number will be 2. Hence, the correct answer is option b.

7. What will come in place of "?"

$\begin{array}{ c c } \hline 4 & 2 \\ \hline \end{array}$ \$ = $\begin{array}{ c c } \hline 2 & 3 \\ \hline \end{array}$	$\begin{array}{ c c } \hline 3 & 6 \\ \hline \end{array}$ \$ = $\begin{array}{ c c } \hline 3 & 8 \\ \hline \end{array}$	$\begin{array}{ c c } \hline 5 & 2 \\ \hline \end{array}$ \$ = ?
$\begin{array}{ c c } \hline 2 & 1 \\ \hline \end{array}$	$\begin{array}{ c c } \hline 0 & 2 \\ \hline \end{array}$	$\begin{array}{ c c } \hline 1 & 4 \\ \hline \end{array}$

- a) $\begin{array}{|c|c|} \hline 6 & 6 \\ \hline \end{array}$ b) $\begin{array}{|c|c|} \hline 6 & 2 \\ \hline \end{array}$ c) $\begin{array}{|c|c|} \hline 4 & 2 \\ \hline \end{array}$ d) $\begin{array}{|c|c|} \hline 4 & 6 \\ \hline \end{array}$

Answer: d

Solution:

In each pair,

Subtract the numbers in the left column before the "=" to get the tens digit after the "=".

Add the numbers in the right column before the "=" to get the ones digit after the "=".

First term:

Before the = sign, we have two columns:

Left column: 4 and 2 (numbers on the left side in both top and bottom rows)

Right column: 2 and 1 (numbers on the right side in both top and bottom rows)

After the = sign, we get 2 and 3.

Now observe the pattern:

- The left number after the = sign is found by subtracting the numbers in the left column: $4 - 2 = 2$
- The right number after the = sign is found by adding the numbers in the right column: $2 + 1 = 3$

So, the result is 2 3.

Applying the same rule to the last term:

Before the = sign, we have:

Left column: 5 and 1

Right column: 2 and 4

Now apply the same steps:

Left number = $5 - 1 = 4$

Right number = $2 + 4 = 6$

So, the box will be divided into two parts with 4 as the first number, and 6 as the second number.

Therefore, the correct answer is option d.

8. If all the rows and columns follow the same rule, then find the missing box in the given image.

4	12	8
?	9	2
7	3	10

a)

b)

c)

d)

Answer: d

Solution:

In the grid, the black box shows the sum of the two white boxes in the same row or column.

For example:

- In one column: $4 + 7 = 11$
- In one row: $9 + 2 = 11$

The same rule applies everywhere.

So, the missing box must be a black box and must contain 11.

Hence, the correct answer is option d.

9. A 4-digit number (which may or may not have repeating digits) is selected such that the sum of its digits is not less than 34. How many single-digit whole numbers will not appear in such numbers?

a) 2

b) 7

c) 8

d) 9

Answer: b

Solution:

We want to make a 4-digit number whose digits add up to 34 or more.

First, let us see which digits can appear in such a number.

The maximum sum using four digits is:

$$9 + 9 + 9 + 9 = 36$$

Now, check what combinations give a sum of 34 or more:

- $9 + 9 + 9 + 7 = 34$
- $9 + 9 + 9 + 8 = 35$
- $9 + 9 + 9 + 9 = 36$
- $9 + 9 + 8 + 8 = 34$

From these examples, we observe that only the digits 7, 8, and 9 can appear in such numbers. If we use any digit smaller than 7 (like 0, 1, 2, 3, 4, 5, or 6), the total sum cannot reach 34.

Therefore, the digits that will NOT appear are:

0, 1, 2, 3, 4, 5, and 6. So, 7 digits will NOT appear in such numbers.

Hence, option b is the correct answer.

10. Each row follows a certain rule. Choose an option for the box with a question mark?

82	10	1
49	13	4
74	11	?

a) 4

b) 2

c) 8

d) 6

Answer: b

Solution:

In this question, each row follows a rule. The digits of the number in the first column are added to get the number in the second column. Similarly, the digits of the number in the second column are added to get the number in the third column.

For example, the number 82 has two digits: 8 and 2. Adding them gives:

$$8 + 2 = 10$$

Then, the digits of 10 are added again:

$$1 + 0 = 1$$

Similarly, in the third row, when we add the digits of the number in the first column, we get:

$$7 + 4 = 11, \text{ which appears in the second column.}$$

Adding the digits of 11 gives:

$$1 + 1 = 2$$

Hence, the correct answer is option b.



The Thinking Spot

Sam collects 2 objects of different colours from each box. If all 6 items which he collected from the 3 boxes are of different shapes, which shapes did he select from Box 1?

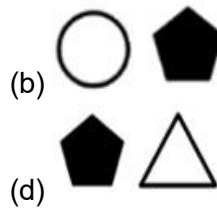
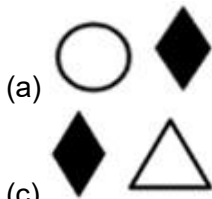
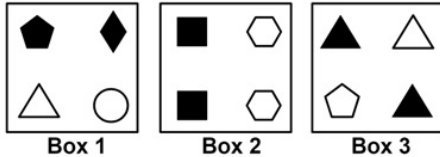

Answer: a

Solution:

Sam collects a total of 6 unique objects, selecting 2 items of different colours and shapes from each box. Since we need to determine which shapes Sam selected from Box 1, we will start by examining Box 2. This is because Box 1 contains all different shapes.

So, we need to deduce the selections from Boxes 2 and 3, which have repeating shapes.

- Box 2 has two identical shapes repeating twice. Therefore, Sam will definitely collect two different shapes: a Square and a Hexagon

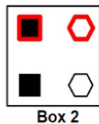

- In Box 3, there is one unique shape (a Pentagon) and three triangles. To collect two different shapes, Sam will take the Pentagon. The second shape he collects cannot be the same colour as the Pentagon. So, he will choose one Black Triangle

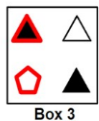

- Now, from Box 1, Sam cannot collect a Pentagon or a Triangle, as he has already collected these shapes from Box 3. Therefore, he will collect the remaining two shapes



Hence, the correct answer is option a.



Chapter 11: Fun with Symmetry

1. As shown below in the question image, a grey circular paper with a round hole in the middle (the white part) is folded along the dotted line. How will it look after folding?

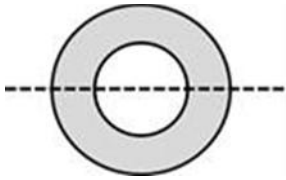

Question image

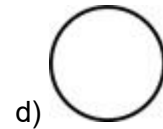
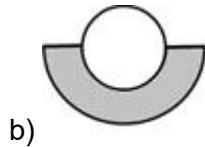

Answer: c

Solution:

The given paper is circular and has a hole at the centre.

When the paper is folded along the dotted line, both the outer circle and the central hole get folded into two equal halves.

Now, check each option:



Option a:

This shows a full grey semicircle without any hole. But the original paper has a hole. So, after folding, half of the hole must be visible. Hence, option a is not correct.

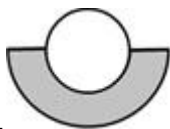

Option b:

This shows a complete white circle (hole). When folded, the hole also gets cut into two halves. So, a full white circle cannot appear. Hence, option b is not correct.

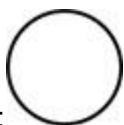

Option d:

This shows only a white circle. But the folded paper must still have the grey outer part along with the hole. Hence, option d is not correct.



Option c:

This shows a half circular grey shape with a half hole, which is exactly what we get when a circular sheet with a central hole is folded along the diameter.

This matches the folding correctly as shown in the image below:

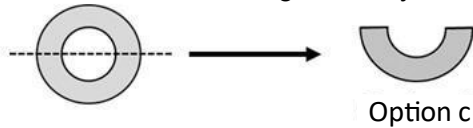

Therefore, the correct answer is option c.

2. Which transparent sheet from the given options, when folded in half as shown by the arrow, will result in Image X?

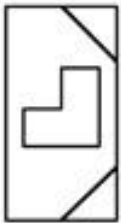
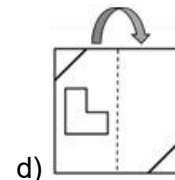
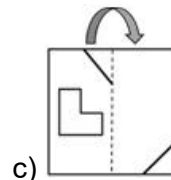
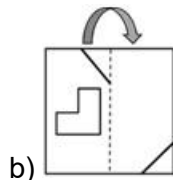
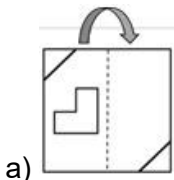

Image X



Answer: d

Solution:

The resultant image of option a will have an L-shape which does not align with the L-shape of Image X.

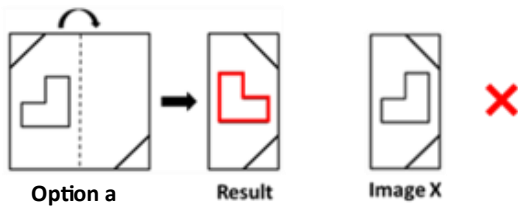

The resultant image of option b will have lines at the diagonally opposite corners and the L-shape aligned in the opposite direction, which is different from Image X.

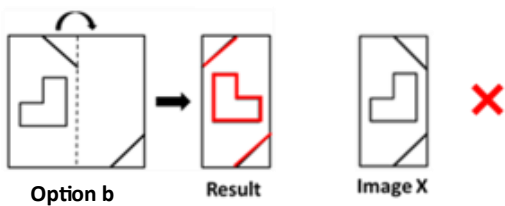

The resultant image of option c will have lines at the diagonally opposite corners, which is different from Image X.



The resultant image of option d exactly matches with Image X, as shown ahead.

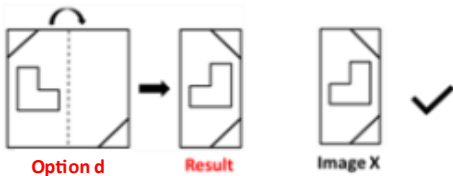

Hence, the correct answer is option d.

3. The given paper X is a transparent sheet with the design shown. If paper X is folded along the dotted line, which of the following options represents the pattern that will appear on the folded paper?

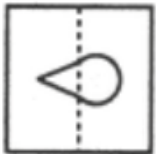

(X)

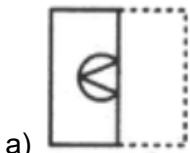

a)

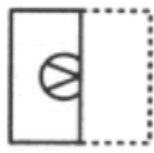

b)

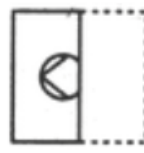

c)

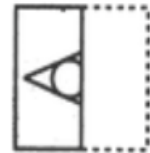

d)

Answer: a

Solution:

As shown below in the image, when we fold the paper X along the dotted line, points A, B, and C will remain at their place and the semi-circle will overlap points A, B, and C. This is only true in option a. Hence, the correct answer is option a.

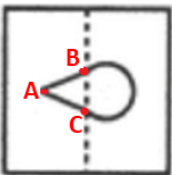

4. Which of the following options DOES not exhibit BOTH vertical and horizontal symmetry together?

a) The alphabet 'O'

b) The alphabet 'E'

c) The alphabet 'H'

d) The alphabet 'I'

Answer: b

Solution:

We will look at each option and then see which one exhibits BOTH vertical and horizontal symmetry.

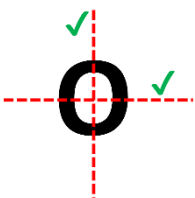

Option a

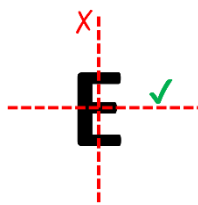

Option b

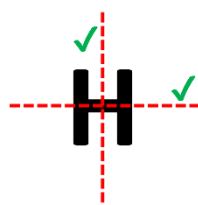

Option c

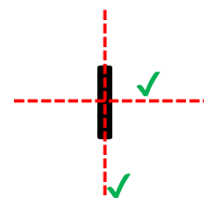

Option d

As we can see, all the options exhibit both vertical and horizontal symmetry except option b. Hence, the correct answer is option b.

5. Which of the following options represents the mirror image of Image A when the mirror is placed along line XY?

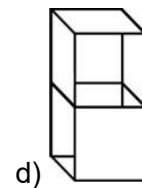
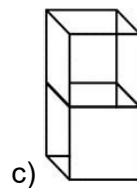
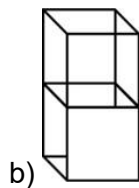
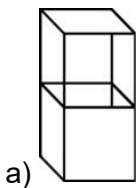
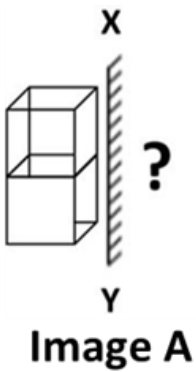

Answer: c

Solution:

Such types of questions must be solved by keenly observing the visual cues.

We know that in a mirror image, the left and right portions interchange.

Let's divide Image A into two halves vertically and observe each portion to detect the minor differences.

Option a:

First, observe the left and right portions of Image A (as highlighted in yellow) individually and compare it with the option image.

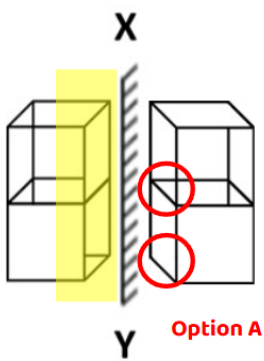

IMAGE 1

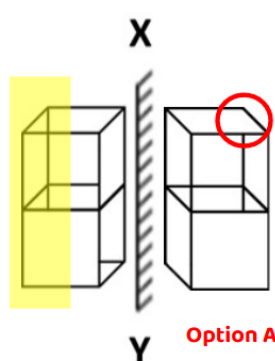

IMAGE 2

Here in IMAGE 1, the bottom right corner of the bottom cube has a horizontal line, which is clearly visible in Image A.

It is missing in option a.

Whereas, the cube above it has no horizontal line at the corner, which is additionally present in the option.

In IMAGE 2, the top right portion of the option must have the vertical line, as in Image A.

Hence, option a is invalid.

Option b:

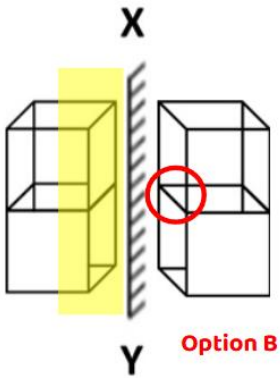

IMAGE 3

The top cube has an additional horizontal line that marks the corner in the option image. This is not present in Image A.

Hence, option b is also invalid.

Option c:

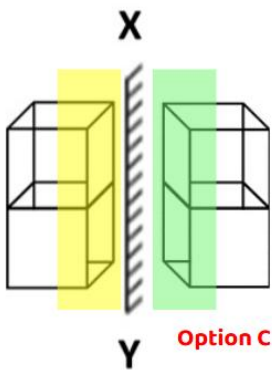

IMAGE 4

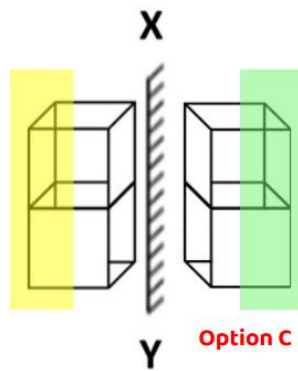

IMAGE 5

All the features (both left and right portions) match with Image A.

Option d:

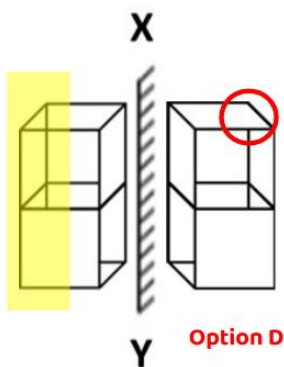

IMAGE 6

Again, the top cube has no vertical line to mark the corner, as in Image A.

Hence, option d is also invalid.

Therefore, option c is the correct answer.

6. What will come in place of "?"



- a)  b)  c)  d) 

Answer: d

Solution:

As shown in the image below, the first 2 terms are repeating and making this sequence. So, the next term will be the same as the 2nd term which is given in option d. Hence, the correct answer is option d.



7. Which type of symmetry(s) is/are present in the given figure?

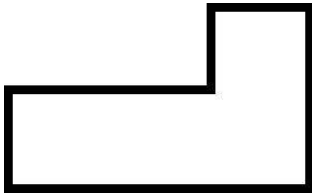

- a) Vertical Symmetry b) Horizontal Symmetry c) Both of these d) None of these

Answer: d

Solution:

An object or shape is said to be vertically or horizontally symmetrical if on cutting the shape vertically or horizontally, it forms two parts which are exactly like each other. For example, in the given shape, if blue and red parts are equal then it would be called symmetrical. As it can be seen, when divided vertically or horizontally, blue and red parts are not equal. Thus, the shape doesn't have any symmetry.

Hence, the correct answer is option d.

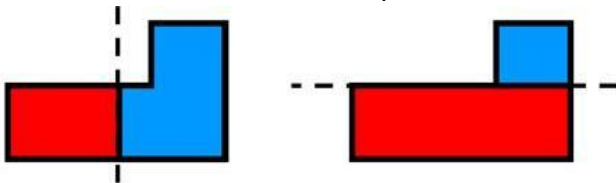

No vertical symmetry

No horizontal symmetry

8. Some letters are written on the board: V, N, A, H, U, X, C, D, K. What fraction of these letters have only vertical symmetry?

- a) $\frac{2}{3}$ b) $\frac{1}{3}$ c) $\frac{1}{2}$ d) $\frac{5}{6}$

Answer: b

Solution:

We will find out the symmetry of each letter and divide them.

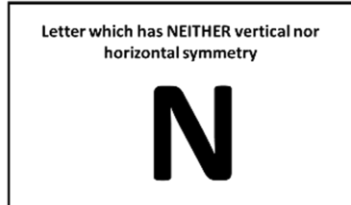
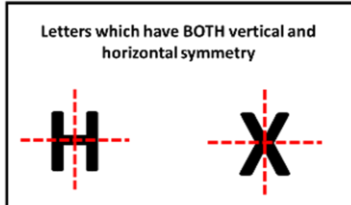
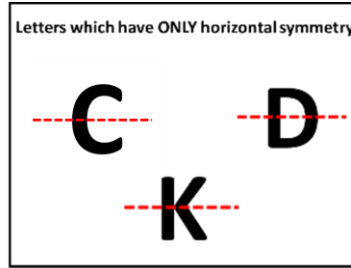
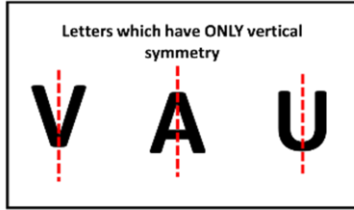

A total of 3 letters have ONLY vertical symmetry among the 9 letters.
 So, the fraction of letters which have ONLY vertical symmetry is $\frac{3}{9} = \frac{1}{3}$.
 Hence, option b is the correct answer.

9. Which image will come in place of the question mark if the Question image is symmetrical?



Question image

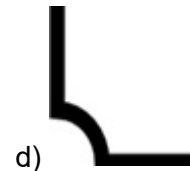
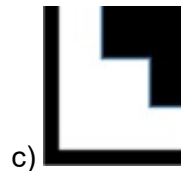
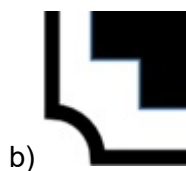
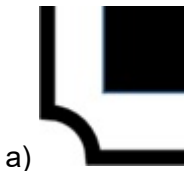

Answer: b

Solution:

We replace the question mark with each option and check whether the complete image becomes symmetrical.



Option a



Option b



Option c



Option d

Option a:

When option a is placed in place of the missing part, the outer frame matches, but the black square inside does not align properly with the inner black shape.

The inner shape becomes uneven, so the left and right sides are not mirror images. option a is not the answer.

Option b:

When option b is placed in place of the missing part:

The outer border completes perfectly and the black shape inside aligns exactly with the top part. Both the left and right sides match completely. The whole image becomes a perfect mirror image from left to right. option b makes the figure symmetrical.

Option c:

In this case, the outer frame becomes straight on one side, which does not match the curved corner on the opposite side.

Because of this mismatch, the figure loses symmetry.

Option c is not the answer.

Option d:

Here, the inner black shape is missing, so even though the outer frame looks similar, the inside part does not balance the inner black shape.

The complete figure is not the answer.

Option d is not symmetrical.

Hence, option b is the correct answer.

10. If Images A and C are mirror images of Image B when a mirror is placed along lines PQ and ST, as shown below, then Images A and C will be _____.

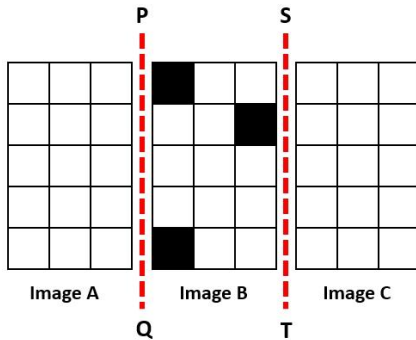

- a) Different from each other
- c) Same as Image B

- b) Same as each other
- d) None of these

Answer: b

Solution:

First, let us find the mirror image of Image B across line PQ to see what appears as Image A.

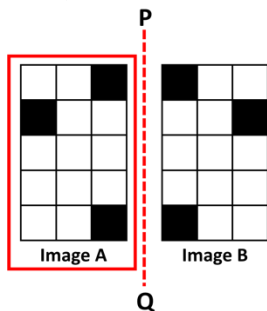

Now, let us find the mirror image of Image B across line ST to see what appears as Image C.

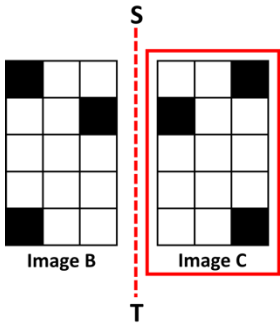

We can see that Image A and Image C are the same.
Hence, option b is the correct answer.



The Thinking Spot

Use the letters N, W, and O to fill in the blanks below to form three meaningful 3-letter English words. If none of the words has repeating letters within itself, which letter will be **COMMON** to all three words?

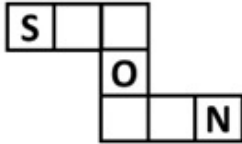

- (a) Only O
- (b) Only N
- (c) Both O and N
- (d) Both W and O

Answer: c

Solution:

We can fill the blanks using the letters N, W, and O, with each letter repeating only once in a word. Considering the first word starts with 'S', two possible meaningful words that can be formed are: SON or SOW.

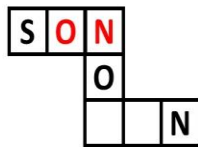

Or

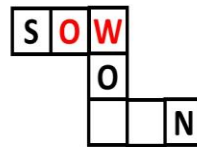

The next word that can be formed is **NOW**.

Here, the next meaningful word that can be formed is **WON**.

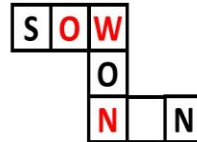
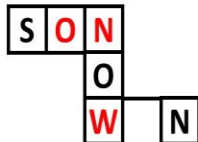

The last word that can be formed is **WON**.

Then, the last word that could be formed is **NON**—however, since no letters can be repeated, this is not possible.

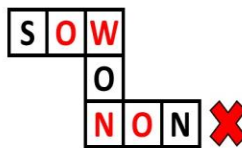
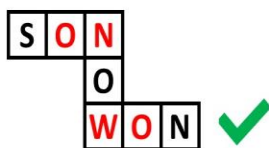

The grid above shows the correct arrangement of letters that form three meaningful words.

Therefore, **WON** cannot be placed here because the bottom horizontal word would then contain two N's, which is not allowed.

Now, let's identify the letters that are common in all three words: SON, NOW, and WON. All three words have both O and N in common. Therefore, the answer is option c.



Chapter 12: Ticking Clocks and Turning Calendar

1. What will come in place of "?"

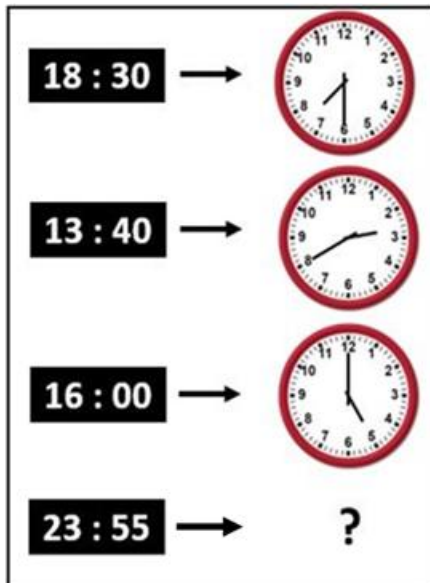

a)



b)



c)



d)

Answer: b

Solution:

The time shown on the clock (on the right side) is 1 hour ahead of the time given on the left side.

For example, in term 1, 1 hour ahead of 18:30 (6:30) is 19:30 (7:30).

Similarly in the last term, 1 hour ahead of 23:55 will be 00:55. Hence, option b is the correct answer.

2. **Ramaswami was studying for his examinations when the lights went off. It was around 1:00 a.m. He lit two uniform candles of equal length, but one was thicker than the other. The thick candle is supposed to last six hours, and the thin candle two hours less. When he finally went to sleep, the thick candle was twice as long as the thin candle. For how long did Ramaswami study in candlelight?**

a) 2 hours

b) 3 hours

c) 2 hours 30 minutes

d) 4 hours

Answer: b

Solution:

Let's solve this logically.

The thick candle lasts for 6 hours and the thin candle lasts for 4 hours (two hours less than 6).

Let's assume that the length of each candle is a number divisible by BOTH 6 and 4 (to make our calculation easier). As 24 (6 x 4) is divisible by both 6 and 4, let's take the length of each candle to be 24 cm.

As the thick candle lasts for 6 hours, the portion of candle burnt each hour = $24/6 = 4$ cm.

Similarly, the portion of thin candle burnt each hour = $24/4 = 6$ cm.

This shows that, in each hour, 4 cm of the thicker candle and 6 cm of the thin candle are consumed.

Consider the SEQUENCE of how the candles are decreased each hour. (The following sequence is taken as a decrease per hour. We can also consider the decrease to be 3 cm and 2 cm per 30 minutes for both thick and thin candles respectively).

	1 hr	2 hr	3 hr	4 hr	
Thick Candle	24	20	16	12	8
Thin candle	24	18	12	6	0

Clearly, in 3 hours, the thick candle is 12 cm and the thin candle is 6 cm.

Here, the thick candle is twice as long as the thin candle.

Hence, Ramaswami studied for 3 hours.

Option b is correct.

3. A man has a job which requires him to work 8 straight days and rest on the ninth day. If he started work on a Monday, the 12th time he rests will be on what day of the week?

- a) Sunday b) Wednesday c) Tuesday d) Friday

Answer: b

Solution:

Twelfth time rest would mean that the man has worked for 12×8 days and has already rested 11 times before. So, the day on which he takes rest for the twelfth time would be the 108th day ($96 + 11 + 1$) since he started.

Since he started work on a Monday, every next Monday comes after a gap of 7 days (1st, 8th, 15th, and so on). Therefore, the 106th day is a Monday, and the 108th day will be a Wednesday.

Hence, option b is the correct answer.

4. Paul is running in a playground. He takes 5 minutes to run one complete round of the playground each time. Also, after every two rounds, he takes a rest of 5 minutes and then starts running again. If he has just completed his 6th round at 4:45 PM, at what time did he start running?

- a) 04:00 PM b) 04:05 PM c) 04:10 PM d) 03:55 PM

Answer: b

Solution:

When Paul has just completed 6 rounds, it means he has run 6 rounds and taken two rests (after rounds 2 and 4). Thus, Paul has spent 40 minutes in total: 30 minutes for 6 rounds and 10 minutes for 2 rest breaks.

Therefore, he must have started running 40 minutes earlier, which is at 4:05 PM.

Hence, the correct answer is option b.

5. Alex takes 10 minutes to reach school, while Tim reaches 15 minutes after Alex. If Tim reaches at 5:00 PM, at what time did Alex leave for school?

- a) 4:40 PM b) 4:45 PM c) 4:35 PM d) 4:30 PM

Answer: c

Solution:

Alex reaches school 15 minutes before Tim.

Tim reaches school at 5:00 PM.

So, Alex reaches school at:

$5:00 \text{ PM} - 15 \text{ minutes} = 4:45 \text{ PM}$

So, the second event must be B (10:30 – 11:00).

Step 3: Third event

After 11:00:

Event A starts at 11:15.

Event C starts only at 12:00.

Since A must come before C, we must choose Event A (11:15 – 11:45).

Step 4: Final event

The only remaining event is C, which starts at 12:00, fitting perfectly.

Final Schedule is D-B-A-C.

This matches option a.

Hence, the correct answer is option a.

8. A clock shows the correct time as 2:30 PM. After this, the minute hand gains 5 extra minutes every half hour. What will be the actual time when the clock shows 9:30 PM?

a) 08:10 PM

b) 08:20 PM

c) 8:30 PM

d) 08:40 PM

Answer: c

Solution:

Step 1: Total hours between 2:30 pm to 9:30 PM = 7 hours

Step 2: Number of 35 minutes in 7 hours = 420 (minutes in 7 hours) / 35 minutes = 12

Step 3: In every half hour, 5 minutes are gained so the total time gained in 7 hours = $12 \times 5 = 60$ minutes

Step 4: Actual time = 9:30 - 60 minutes = 8:30 PM

Step 5: When the clock shows 9:30 PM, the actual time will be 8:30 PM

Hence, the correct answer is option c.

9. Our cricket match is going to take place on the last day of the 4th month of the year. On which of the following dates will we have our match?

a) 31st April

b) 31st May

c) 30th April

d) 30th May

Answer: c

Solution:

The 4th month of the year is April. The last day of this month is 30th April.

Hence, the correct answer is option c.

10. A sequence of time periods is given: 2 PM to 4:40 PM, 3:20 AM to 6 AM, 11:30 AM to 2:10 PM, 7 PM to 9:40 PM. What would be the rule that is governing this sequence?

a) The number of minutes in each of these time periods is 140

b) The number of minutes in each of these time periods is 160

c) The number of minutes in each of these time periods is different

d) None of these

Answer: b

Solution:

From 2 PM to 4:40 PM, we have an interval of 2 hours and 40 minutes, that is 160 minutes.

Similarly, from 3:20 AM to 6 AM, we have an interval of 2 hours and 40 minutes, that is 160 minutes.

The same follows for all the terms.

Hence, the correct answer is option b.

11. Each month of the year has at least 28 days. Which of the given options can be understood from the given statement?

a) A year has at most 390 days

b) A year has at least 336 days

c) Some years have 350 days

d) Every month of the year has only 28 days

Answer: b

Solution:

A year has 12 months. So, if each month has at least 28 days, a year has at least 12×28 days, that is 336 days. Hence, the correct answer is option b.

12. The conditions below help us find when Jaanhavi was born.

- Jaanhavi's birth month starts with A.

- Jaanhavi's birth month has 5 letters.

- Jaanhavi was born on an even date.

- Jaanhavi was born between the 20th and 30th of the month.

When was Jaanhavi born?

a) April 22nd

b) April 25th

c) August 20th

d) April 12th

Answer: a

Solution:

Jaanhavi's birth month starts with the letter A, so it can be April or August.

Her birth month has 5 letters, which means the month must be April (since "August" has 6 letters).

Now, from the options given, we need an even date that falls between the 20th and the 30th.

The only option that satisfies all these conditions is:

April 22nd

Therefore, April 22nd is the correct answer.

Hence, the correct answer is option a.



The Thinking Spot

2 circles, a triangle, and a square are packed in the given boxes, one shape in each box.

- The circles are placed in the adjacent boxes
- The square and the triangle are NOT present in the adjacent boxes

Given that you know the above information, at a minimum, how many boxes must you open to identify the specific shape present in each box?

Note: *Adjacent means adjoining or next to something*



(a) 3

(b) 2

(c) 1

(d) 0

Answer: c

Solution:

- Arrangement Possibilities:

Since the circles must be in adjacent boxes and cannot be placed at the edges (as that would force the square and triangle to be adjacent), the circles can only be in the middle boxes. Therefore, there are only two possible arrangements of the shapes in the boxes, as shown in Image A.

- Opening Boxes:

By opening any of the boxes at the extreme corners (Box 1 or Box 4), you can determine which shape is present in that box, leading to the identification of the other shapes.

- Case Analysis:

If you open Box 1 and find:

- Square:

Then, Box 2 and Box 3 must contain circles, and Box 4 must contain a triangle.

- Triangle:

Then, Box 2 and Box 3 must contain circles, and Box 4 must contain a square.

Conclusion:

Therefore, by opening just one box (Box 1 or Box 4), you can determine the arrangement of all shapes in the boxes.



Image A

Thus, option c is the correct answer.



Chapter 13: The Transport Museum

1. A train can carry four times the passengers as that of a bus. Which of these statements gives the same information as the given statement?

- a) Bus is smaller than Train
- b) Capacity of a bus is a quarter of the capacity of a train
- c) Ship is larger than a Train
- d) All of these

Answer: b

Solution:

If a train can carry four times the passengers of a bus, then the capacity of the train is four times that of the bus, or equivalently, the capacity of a bus is a quarter of the capacity of a train.

Hence, the correct answer is option b.

2. Bholu, Shalu, and Rinku distributed 120 bananas equally among themselves. Which of the given statements can be TRUE?

- a) Bholu has more than 35 bananas
- b) Shalu has 40 bananas
- c) Rinku has less than 60 bananas
- d) All of these

Answer: d

Solution:

The total number of bananas is 120. They are distributed equally among Bholu, Shalu, and Rinku. Thus, each gets one-third of 120 bananas ($120/3 = 40$). That is 40 bananas.

Let us analyse each option one by one:

Option A: Bholu has more than 35 bananas

Everyone has 40 bananas. Hence, Bholu has more than 35 bananas.

Option B: Shalu has 40 bananas

Everyone got 40 bananas. Hence, Shalu also has 40 bananas.

Option C: Rinku has less than 60 bananas

Rinku has 40 bananas. Hence, this statement is also true.

Hence, all the statements are true. Thus, option d is the correct answer.

3. There are three brothers: Sumit, Suraj, and Sagar. The product of their ages is 175. Sumit and Suraj are twins. How old is Sagar?

- a) 5
- b) 6
- c) 7
- d) 8

Answer: c

Solution:

The product of the ages of the three brothers is 175. Since Sumit and Suraj are twins, their ages are the same. So, if Sagar's age is removed from the total product, the remaining value must be able to split into two equal whole-number ages for the twins.

This means Sagar's age must be a number that divides 175 exactly and leaves a quotient that can be written as the same number multiplied by itself (for example, 2×2 , 3×3).

Trying possible ages:

- If Sagar is 5 years old, the remaining value is $175 \div 5 = 35$, which cannot be split into two equal ages.
- If Sagar is 6 years old, when 175 is divided by 6, the remainder is 1. Therefore, 175 is not exactly divisible by 6. So, option b cannot be the answer.

- If Sagar is 7 years old, the remaining value is $175 \div 7 = 25$, which can be split as 5×5 .

This satisfies all the given conditions. Therefore, Sagar is 7 years old.

Hence, option c is correct.

4. Shreya has 10 toffees, Kriti has 12 toffees, Aishwarya has 14 toffees, and Aditi has 18 toffees. Which two of them have a number of toffees that can be shared equally among three people?

- a) Kriti and Aditi
b) Shreya and Kriti
c) Aishwarya and Aditi
d) Aditi and Shreya

Answer: a

Solution:

To distribute the toffees equally among 3 people, the number of toffees should be a multiple of 3.

Only Kriti and Aditi have toffee counts that are exact multiples of 3. 12 toffees can be shared equally among 3 people, and 18 toffees can be shared equally among 3 people.

Hence, the correct answer is option a.

5. A cube of side length 8 cm is cut into 64 smaller cubes of equal size. What would be the side length of each smaller cube formed?

- a) 1 cm
b) 4 cm
c) 2 cm
d) None of these

Answer: c

Solution:

The big cube has a side length of 8 cm.

It is cut into 64 smaller cubes, all of the same size.

Now think like this:

A cube is cut lengthwise, breadthwise, and height wise.

Since, $64 = 4 \times 4 \times 4$, this means the big cube is cut into 4 equal parts along each edge as shown in the image below.

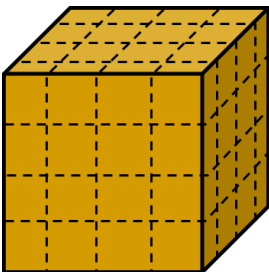

So, along one side of the cube:

Total length = 8 cm

Number of equal parts = 4

Side length of each small cube:

$$8 \div 4 = 2 \text{ cm}$$

So, each smaller cube has a side length of 2 cm.

Therefore, the correct answer is option c.

6. An online sale for electronic gadgets lasts for 3 hours. The entire buying process for one product takes 10 minutes. Sameer manages to buy the maximum number of products during the sale hours. Since he needs more products, he calls his friend to help buy the remaining products one hour before the end of the sale. What is the maximum number of products both of them can buy together during the sale?

- a) 22
b) 24
c) 28
d) 20

Answer: b

Solution:

In the 3-hour sale time, since each product purchase and payment process takes 10 minutes, Sameer can make $(180 \text{ minutes} / 10 \text{ minutes per product}) = 18$ purchases.

Sameer's friend joins the purchase process; they can buy products simultaneously. Thus, within the remaining 60 minutes, his friend can make $(60 \text{ minutes} / 10 \text{ minutes per product}) = 6$ purchases.

So, the maximum number of products that can be bought are $= 18 + 6 = 24$.

Thus, option b is the correct answer.

7. Based on the equations given below, find the value of the triangle.

$$4 \times 8 = \blacksquare$$

$$5 \times 6 = \bigcirc$$

$$\blacksquare \times \bigcirc = \blacktriangle$$

a) 96

b) 720

c) 960

d) 992

Answer: c

Solution:

$$4 \times 8 = 32$$

$$\text{Square} = 32$$

$$5 \times 6 = 30$$

$$\text{Circle} = 30$$

As the triangle is the product of the square and circle,

$$\text{Triangle} = 32 \times 30$$

	H	T	O
		3	2
X		3	0
		0	0
+	9	6	0
	9	6	0

Thus, Triangle = 960

Hence, the correct answer is option c.

8. Which of the following statements is/are sufficient to answer the given question?

Question: X is a 3-digit number. Is X divisible by 3?

Statement 1: Both the first and last digits of X are divisible by 3

Statement 2: X is a prime number

a) Only statement 1 alone is sufficient

b) Only statement 2 alone is sufficient

c) Both 1 and 2 are together required

d) Question cannot be answered even if both pieces of information are used

Answer: b

Solution:

The question asks whether X is divisible by 3.

From Statement 1, we know that the first and last digits are divisible by 3. However, a number is divisible by 3 only if the sum of all its digits is divisible by 3. Since we do not know the middle digit, we cannot determine the sum of the digits. Therefore, Statement 1 alone is not sufficient.

From Statement 2, we are told that X is a prime number.

A prime number has only two factors:

1 and the number itself.

If a number were divisible by 3, then 3 would also be a factor of that number.

That would mean the number has more than two factors, so it cannot be prime.

Since X is a 3-digit prime number, it cannot be divisible by 3.

So, the answer to the question can be found using Statement 2 alone.

Therefore, only statement 2 is sufficient.

Hence, option b is the correct answer.

9. P, Q, R, S, and T buy mangoes in each round. They have 4 rounds, and the following conditions apply in every round:

- Each person buys a different number of mangoes, ranging from 1 to 5
- P buys the least, T buys the most, and R buys more than Q but less than S
- After 4 such rounds, all the mangoes are shared equally among the five of them

Who gets the same number of mangoes as the total number of mangoes that he himself buys?

a) P

b) Q

c) R

d) S

Answer: c

Solution:

In each round, the mangoes bought are numbers from 1 to 5.

Since P buys the least and T buys the most, $P = 1$ and $T = 5$.

Also, R buys more than Q but less than S,

So, $Q = 2$, $R = 3$, and $S = 4$.

The total mangoes bought in one round = $1 + 2 + 3 + 4 + 5 = 15$.

In 4 rounds, total mangoes = $15 \times 4 = 60$.

When shared equally among 5 people, each gets $60 \div 5 = 12$ mangoes.

P bought 4 mangoes in 4 rounds, which is not equal to his share (12).

Q bought 8 mangoes in 4 rounds, which is not equal to his share (12).

R bought 12 mangoes in 4 rounds, which is equal to his share (12).

S bought 16 mangoes in 4 rounds, which is not equal to his share (12).

T bought 20 mangoes in 4 rounds, which is not equal to his share (12).

Therefore, only R gets a share equal to the total number of mangoes he himself bought.

Hence, the correct answer is option c.

10. In a garden, plants are arranged in 140 rows and 2 columns, where each row has the same number of plants. If the same number of plants are rearranged in a different number of rows and columns, with each row having the same number of plants, which of the following would never be the number of plants in a row?

a) 70

b) 40

c) 30

d) 28

Answer: c

Solution:

In the given arrangement, the plants are placed in 140 rows and 2 columns.

So, the total number of plants is:

$$140 \times 2 = 280 \text{ plants}$$

When the plants are rearranged, the total number of plants remains the same.

Only the number of rows and columns changes.

This means that the number of plants in each row must be a number that can divide 280 exactly, so that all rows have the same number of plants.

Now check the options:

- 70 can be the number of plants in a row because $280 \div 70 = 4$
- 40 can be the number of plants in a row because $280 \div 40 = 7$
- 30 cannot be the number of plants in a row because $280 \div 30$ is not a whole number
- 28 can be the number of plants in a row because $280 \div 28 = 10$

Since 30 cannot divide 280 exactly, it can never be the number of plants in a row.

Hence, option c is the correct answer.



The Thinking Spot

You have four white-coloured strips, each containing five items. If each strip can be moved one column to the left or right, then which item can occupy the same column for all the strips?

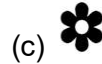
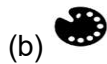
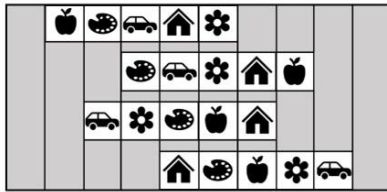

Answer: a

Solution:

The approach is to find the difference between the columns where the same item is placed across all the strips. Each strip can be moved only one step to the left or right. Therefore, the maximum difference between the positions of items in each strip should be 2 or less, so that all the items can align in a single column.

If the difference between any of the items is greater than 2, they cannot align.

Analysing Each Option:

Option a: House

- Present in Columns: 5, 7, 7, and 5
- Maximum difference = $7 - 5 = 2$

Option b: Palette

- Present in Columns: 3, 4, 5, and 6
- Maximum difference = $6 - 3 = 3$

Option c: Flower

- Present in Columns: 6, 6, 4, and 8
- Maximum difference = $8 - 4 = 4$

Option d: Apple

- Present in Columns: 2, 8, 6, and 7
- Maximum difference = $8 - 2 = 6$

The only option that satisfies the condition of a maximum difference of 2 or less is option a (House).

The strips will move one step each as shown below.

Thus, House will be the item that will align.

Hence, option a is the correct answer.

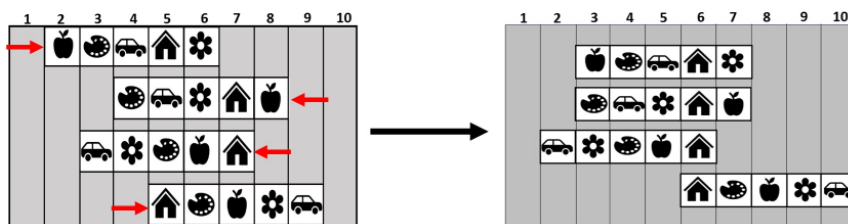

Chapter 14: Data Handling

1. John took an exam in which he received 4 marks for each CORRECT answer and lost 1 mark for each INCORRECT answer.

The following table shows John's scores in each exam, where a few of the values are missing. What is the TOTAL number of questions John attempted in all three exams?

SUBJECTS	No. of CORRECT QUESTIONS	No. of INCORRECT QUESTIONS	TOTAL MARKS SCORED
MATHS	8		26
SCIENCE		4	48
ENGLISH	18		65

- a) 40 b) 48 c) 55 d) 56

Answer: d

Solution:

Each correct answer earns 4 marks, while each incorrect answer deducts 1 mark.

1. In MATHS, with 8 correct answers, the total score is 32 marks. However, the total score obtained is 26, indicating a deduction of 6 marks due to incorrect answers. Therefore, 6 questions were answered incorrectly. Total questions answered are 14 ($8 + 6 = 14$).

2. Similarly, for SCIENCE, the total marks are 48, and 4 questions were answered incorrectly. To find the correct number of questions, we add back the deducted marks (4) and divide the total score (52) by 4, resulting in 13 correct questions. Total questions answered are 17 ($13 + 4 = 17$).

3. We will use the same deduction method as in MATHS. The total score in ENGLISH is 65.

With 18 correct answers, John should score 72 marks, but he scored 65, which means 7 marks were deducted. Therefore, 7 questions were answered incorrectly. Total questions answered are 25 ($18 + 7 = 25$).

Thus total number of questions answered are: $14 + 17 + 25 = 56$, hence, 56 questions were attempted.

SUBJECTS	No. of CORRECT QUESTIONS	No. of INCORRECT QUESTIONS	TOTAL MARKS SCORED
MATHS	8	6	26
SCIENCE	13	4	48
ENGLISH	18	7	65

Thus, the correct answer is option d.

2. The table given below gives marks of 3 friends A, B, and C in 4 different subjects. In how many subjects has C scored more marks than B but less marks than A?

	English	Mathematics	Science	Hindi
A	70	65	95	82
B	72	80	75	67
C	80	77	60	73

- a) 0 b) 1 c) 2 d) 3

Answer: b

Solution:

Let us analyse marks of C in each subject one by one:

English:

Here, C scored the highest. Hence, the condition is not satisfied that C has to score less than A.

Mathematics:

Here, C scored less than B. Hence, the condition is not satisfied.

Science:

Here, C scored the least marks. Hence, the condition is not satisfied.

Hindi:

Here, C scored more than B but less than A. Hence, all the conditions are satisfied.

There is only one subject where C scored more than B but less than A.

Hence, the correct answer is option b.

3. Each shop sells two types of fruits among Apples, Bananas, Mangoes, and Strawberries. The fruits displayed in a shop are the ones NOT sold there.

- Bob bought all the fruits available in SHOP A
- Tom bought all the fruits available in SHOP B

Which fruit did they buy in common?



- a) Bananas b) Mangoes c) Strawberries d) Apples

Answer: b

Solution:

Each shop sells two types of fruits among Apples, Bananas, Mangoes, and Strawberries. The key rule given is:

The fruits displayed in a shop are the ones that are NOT sold there.

Step 1: Identifying the Fruits Sold in each shop

- SHOP A displays Strawberries and Apples, meaning it sells Bananas and Mangoes
- Bob bought all the fruits sold in SHOP A: Bananas and Mangoes
- SHOP B displays Apples and Bananas, meaning it sells Strawberries and Mangoes
- Tom bought all the fruits sold in SHOP B: Strawberries and Mangoes

Step 2: Finding the Common Fruit

- Bob bought: Bananas and Mangoes
- Tom bought: Strawberries and Mangoes
- Common fruit: Mangoes

Hence, option b is the correct answer.

4. If the number of units sold by a company each month follows the pattern shown below, and the same trend continues till the end of the year, how many units were sold in one year?

Month 1	Month 2	Month 3	Month 4
9	19	29	39

- a) 768 units b) 897 units c) 649 units d) None of these

Answer: a

Solution:

The company's sales increase by 10 units every month.

Month 1: 9

Month 2: 19

Month 3: 29

Month 4: 39

Each month we keep adding 10 more.

To find the sales in 12 months, we continue the pattern:

Month 5: 49
Month 6: 59
Month 7: 69
Month 8: 79
Month 9: 89
Month 10: 99
Month 11: 109
Month 12: 119

Now, we add all these 12 numbers:

$$9 + 19 + 29 + 39 + 49 + 59 + 69 + 79 + 89 + 99 + 109 + 119 = 768$$

So, the company sold 768 units in one year.

Hence, the correct answer is option a.

5. Some information about the number of pencils each student has is shown in the image below. Which two students, if they put their pencils together, can share them equally among five students?

Student	Number of pencils
Pranav	12
Tarun	16
Meenakshi	6
Sanjay	10
Sheetal	13

- a) Pranav and Sheetal
b) Tarun and Sanjay
c) Pranav and Meenakshi
d) Tarun and Pranav

Answer: a

Solution:

Pranav has 12 pencils and Sheetal has 13 pencils. When added together, they have 25 pencils, which is a multiple of 5. Hence, option a is the correct answer.

6. The table given below gives the marks of 4 friends, A, B, C, and D, in 4 different subjects. Who among them got the least marks in more than one subject?

	English	Maths	Science	Hindi
A	70	65	75	67
B	72	80	88	78
C	80	73	60	85
D	90	57	85	82

- a) A
b) B
c) C
d) D

Answer: a

Solution:

We check each subject and note who got the least marks.

English:

A = 70, B = 72, C = 80, D = 90. Least: A

Maths:

A = 65, B = 80, C = 73, D = 57. Least: D

Science:

A = 75, B = 88, C = 60, D = 85. Least: C

Hindi:

A = 67, B = 78, C = 85, D = 82. Least: A

Now count how many times each person got the least marks:

A: English, Hindi. 2 times

B: 0 times

C: Science. 1 time

D: Maths. 1 time

A got the least marks in more than one subject.

Hence, the correct answer is option a.

7. I was NOT born on Tuesday, Thursday, or Saturday. My friend was NOT born on Monday, Wednesday, or Sunday. If both of us were born on the same day, on which day were we born?

a) Sunday

b) Monday

c) Friday

d) Saturday

Answer: c

Solution:

Referring to the following table, if both were born on the same day, then it would be Friday according to the given information.

Day of the week	You were born	Your friend was born
Sunday	✓	✗
Monday	✓	✗
Tuesday	✗	✓
Wednesday	✓	✗
Thursday	✗	✓
Friday	✓	✓
Saturday	✗	✓

Hence, the correct answer is option c.

8. In a survey of 40 Men and 40 Women, the following results were obtained based on their interests in Cricket and Chess. The number of people who like BOTH Chess and Cricket are GREATER from which of these categories?

MEN

Like Cricket	25
Like Chess	15
Neither Cricket nor Chess	10

WOMEN

Like Cricket	15
Like Chess	28
Neither Cricket nor Chess	8

a) Men

b) Women

c) Both categories have an equal number of people who like both the games

d) Cannot be determined

Answer: b

Solution:

The survey is based on the information from 40 Men and 40 Women.

Men:

Number of Men who like Cricket = 25

Number of Men who like Chess = 15

Number of Men who neither like Cricket nor Chess = 10

Total Men = Number of men who like Cricket + Number of Men who like Chess + Number of Men who neither like Cricket nor Chess - Number of Men who like Both games

40 = 25 + 15 + 10 - Number of Men who like Both games
 Number of Men who like both games = 25 + 15 + 10 - 40 = 10.

Women:

Number of Women who like Cricket = 15

Number of Women who like Chess = 28

Number of Women who neither like Cricket nor Chess = 8

Total Women = Number of women who like Cricket + Number of women who like Chess + Number of women who neither like Cricket nor Chess - Number of women who like Both games

40 = 15 + 28 + 8 - Number of women who like Both games

Number of women who like both games = 15 + 28 + 8 - 40 = 11.

Hence, the number of people who like BOTH Chess and Cricket are GREATER among Women.

Hence, the correct answer is option b.

9. Some buildings have pet restrictions. The tallest building bans dogs, the second tallest bans cats, and the shortest bans rabbits. If Sam has all three pets, where can he live?

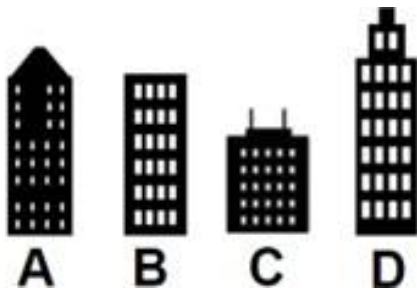

a) A

b) B

c) C

d) D





Answer: b

Solution:

The pet restrictions are shown in the table below:

- The tallest building bans dogs. D is the tallest building. So, building D bans dogs.
- The second tallest building bans cats. A is the second tallest building. So, building A bans cats.
- The shortest building bans rabbits. C is the shortest building. So, building C bans rabbits.

So, the only building where Sam can live with his three pets is Building B.

	Building			
Pet Restrictions	 A	 B	 C	 D
Dog		✓		✗
Cat	✗	✓		
Rabbit		✓	✗	

Hence, the correct answer is option b.

10. A rabbit, a snake, a monkey, and a frog are named Jack, John, Joe, and Jude.
Use the clues below to find who Jude is.

Clues:

1. Joe and the rabbit like each other
2. The frog is named John
3. Jack is not the rabbit

Who is Jude?

a) Rabbit

b) Snake

c) Monkey

d) Frog

Answer: a

Solution:

	Jack	John	Joe	Jude	Reason
Rabbit	X		X	✓	
Snake					
Monkey					
Frog		✓			From point 2

From Clue 2, the frog is named John, so John is not the rabbit.

From Clue 1, Joe and the rabbit like each other, so Joe is not the rabbit.

From Clue 3, Jack is not the rabbit.

Therefore, the rabbit is not John, Joe, or Jack.

The only name left is Jude.

So, Jude is the rabbit.

Hence, the correct answer is option a.



The Thinking Spot

Given below is a part of a 5 x 4 grid. Which of the following will COMPLETE the grid such that every row has exactly 3 circles?

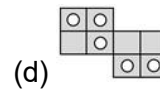
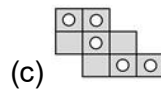
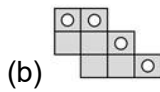
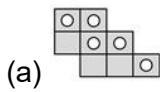
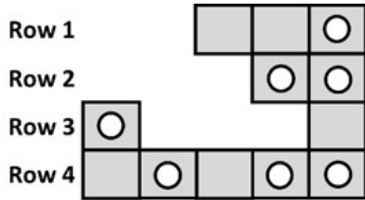

Answer: c

Solution:

Given below is a part of 5 x 4 grid where each row must contain exactly 3 circles.

- Row 1: There are 3 blocks and only 1 circle present. So, it needs 2 more blocks with circles. All options satisfy this condition.
- Row 2: There are 2 blocks and 2 circles present. So, it requires 3 more blocks and 1 more circle.
 - Option d is eliminated as it shows 4 blocks instead of 3.
 - Option a is eliminated because it has 2 circles instead of 1.

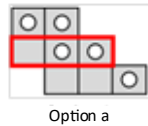
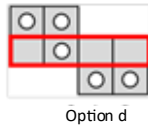

- Row 3: Has 2 blocks and 1 circle present. So, it needs 3 more blocks and 2 more circles. Option b is eliminated because it has 1 circle instead of 2.

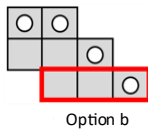

Hence, option c is the correct answer as shown below in the image.

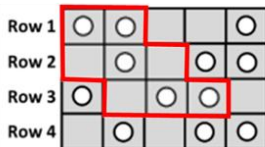



CENTRAL BOARD OF SECONDARY EDUCATION

Academic Unit VI Floor, CBSE Integrated Office, Sector 23, Dwarka, New Delhi-110077