

CBSE | DEPARTMENT OF SKILL EDUCATION

ELECTRICAL TECHNOLOGY (SUBJECT CODE-819)

MARKING SCHEME FOR CLASS XII (SESSION 2023-2024)

Max. Time: 3 Hours

Max. Marks: 60

General Instructions:

1. Please read the instructions carefully.
2. This Question Paper consists of **24 questions** in two sections – Section A & Section B.
3. Section A has Objective type questions whereas Section B contains Subjective type questions.
4. **Out of the given (6 + 18 =) 24 questions, a candidate has to answer (6 + 11 =) 17 questions in the allotted (maximum) time of 3 hours.**
5. All questions of a particular section must be attempted in the correct order.
6. **SECTION A - OBJECTIVE TYPE QUESTIONS (30 MARKS):**
 - i. This section has 06 questions.
 - ii. There is no negative marking.
 - iii. Do as per the instructions given.
 - iv. Marks allotted are mentioned against each question/part.
7. **SECTION B – SUBJECTIVE TYPE QUESTIONS (30 MARKS):**
 - i. This section contains 18 questions.
 - ii. A candidate has to do 11 questions.
 - iii. Do as per the instructions given.
 - iv. Marks allotted are mentioned against each question/part.

SECTION A: OBJECTIVE TYPE QUESTIONS

Q. No.	QUESTION	Source Material (NCERT/PSSCI VE/ CBSE Study Material)	Unit/ Chap. No.	Page No.	Marks
Q. 1	Answer any 4 out of the given 6 questions on Employability Skills (1 x 4 = 4 marks)				
i.	It is the process of creating a non-fiction text about specific topics.	NCERT	Comm. Skill		1
ii.	It is a personality disorder in which we believe that other people do not like us.	NCERT	Self Mgmt.		1
iii.	Plant trees, recycling	NCERT	Green Skills		1
iv.	It is the main work area to create or modify individual slides.	NCERT	ICT		1
v.	By increasing our energy and keep us active.	NCERT	Self Mgmt.		1
vi.	Overall development of a student	NCERT	EMC		1
Q. 2	Answer any 5 out of the given 7 questions (1 x 5 = 5 marks)				
i.	C. 98%	CBSE Study Material	Transformer		1
ii.	A. Air core	CBSE Study Material	Transformer		1
iii.	B. increase	CBSE Study Material	DC/AC Motor		1
iv.	B. Starting torque	CBSE Study Material	Elec. Appliances		1
v.	A. high	CBSE Study Material	AC Circuit		1
vi.	A. Ohmmeter	CBSE Study Material	Measuring Instruments		1
vii.	C. reduction of flux	CBSE Study Material	Elec. Appliances		1
Q. 3	Answer any 6 out of the given 7 questions (1 x 6 = 6 marks)				

i.	Starting Winding	CBSE Study Material	Elec. Appliances		1
ii.	Mutual Induction	CBSE Study Material	Transformer		1
iii.	To give high voltage	CBSE Study Material	DC/AC Motor		1
iv.	Motor will stop.	CBSE Study Material	3-phase motor		1
v.	Capacitor Motor, Universal Motor	CBSE Study Material	Elec. Appliances		1
vi.	Yes	CBSE Study Material	Measuring Instruments		1
vii.	2.5	CBSE Study Material	Elec. Appliances		1
Q. No.	QUESTION	Source Material (NCERT/PSSCI VE/ CBSE Study Material)	Unit/ Chap. No.	P a g e n o	Marks
Q. 4	Answer any 5 out of the given 6 questions (1 x 5 = 5 marks)				
i.	True	CBSE Study Material	Elec. Appliances		1
ii.	True	CBSE Study Material	DC/AC Motor		1
iii.	True	CBSE Study Material	3-phase motor		1
iv.	False	CBSE Study Material	Measuring Instruments		1
v.	True	CBSE Study Material	Elec. Appliances		1
vi.	False	CBSE Study Material	Elec. Appliances		1
Q. 5	Answer any 5 out of the given 6 questions (1 x 5 = 5 marks)				
i.	KVAR	CBSE Study Material	AC Circuit		1
ii.	ohms	CBSE Study Material	Measuring Instruments		1
iii.	oil cooling	CBSE Study Material	Transformer		1
iv.	Two	CBSE Study Material	DC/AC Motor		1
v.	Induction	CBSE Study Material	3-phase motor		1
vi.	parallel	CBSE Study Material	Elec. Appliances		1
Q. 6	Answer any 5 out of the given 6 questions (1 x 5 = 5 marks)				
i.	B. voltage	CBSE Study Material	Transformer		1
ii.	B. DC series motor	CBSE Study Material	DC/AC Motor		1
iii.	D. All the above	CBSE Study Material	Elec. Appliances		1
iv.	C. be four times	CBSE Study Material	3-phase motor		1
v.	B. Moving coil meter	CBSE Study Material	Measuring Instruments		1
vi.	D. Capacitor run	CBSE Study Material	Elec. Appliances		1

SECTION B: SUBJECTIVE TYPE QUESTIONS

Q. No.	QUESTION	Source Material (NCERT/PSSCIV E/ CBSE Study Material)	Unit/ Chap. No.	Page no	Marks
Answer any 3 out of the given 5 questions on Employability Skills in 20 – 30 words each (2 x 3 = 6 marks)					
Q. 7	It affects all aspects of individual performance given how he reacts to situation in life they set clear goals and pursue them behavior like anxiety, stress can influence it.	NCERT	Skill Mgmt.		2
Q. 8	Dream big, try new challenges, plan and execution, recognize opportunity, bounce back from failures	NCERT	EMC		2
Q. 9	Listening is active while hearing is passive's Listening requires conscious efforts while hearing does not.	NCERT	Comm. Skills		2
Q. 10	As household are switching to solar energy Families are purchasing energy cars	NCERT	Green Skills		2
Q. 11	Title bar, menu bar, formatting bar, standard bar, drawing bar	NCERT	ICT		2
Answer any 3 out of the given 5 questions in 20 – 30 words each (2 x 3 = 6 marks)					
Q. 12	Construction of DC Motor DC motor classified like shunt series and compound motor. In DC motor commutator provides unidirectional torque. In DC motor one conductor placed in a slot of armature which is under the magnetic field of North Pole. Similarly, a conductor which is directly opposite to this conductor is under the effect of South Pole.	CBSE Study Material	DC/AC Motor		2
Q. 13	TYPES OF TRANSFORMER 1. Step-up transformer 2. Step-down transformer 3. Voltage transformer 4. Current transformer 5. Auto transformer	CBSE Study Material	Transformer		2
Q. 14	1. Before testing water heater, insulate yourself on the dry wood. 2. Test the water heater in series of the electric supply to avoid the risk of failure of supply. 3. Never give direct supply unless you are sure that there is no fault in the water heater to avoid the risk of failure of supply. 4. Use three-wire cord for the supply. 5. The water should be switched on to mains only after it is dipped in the water. 6. Dip the water heater up to the indicated mark and don't allow terminal housing to be immersed in water. 7. First switch off the current then remove water heater from the water. 8. Don't take out the rod from water at once as soon as you switched off the supply. 9. Don't use the immersion heater in other liquids because it is meant for water only and in other liquids, it will have a corroding affect on its surface. Any four among above.	CBSE Study Material	Elec. Appliances		2
Q. 15	Increase in copper losses, overload, cost increase, great voltage regulation	CBSE Study Material	AC Circuit		2
Q. 16	<ul style="list-style-type: none"> Remove obstructions from the route. For a long lift, plan to rest the load midway on a table or bench to change grip. Keep the load close to the waist. The load should be kept close to the body for as long as possible while lifting. 	CBSE Study Material	Elec. Appliances		2

- Keep the heaviest side of the load next to the body.
- Adopt a stable position and make sure your feet are apart, with one leg slightly forward to maintain balance.

Answer any 2 out of the given 3 questions in 30– 50 words each (3 x 2 = 6 marks)

<p>Q. 17</p>	<p>COOLING OF TRANSFORMER - Practically ideal transformer produces some losses most of them transformed into heat which is not dissipated from the transformer properly. The increase in temperature may cause several errors. Therefore, transformer required cooling system for hustle free function. Transformer can be divided in two types-</p> <p>1. Dry type transformer 2. Oil immersed transformer</p> <p>Cooling method for dry type transformers</p> <p>1. Natural air-cooled transformer- The small transformer of low rating up to 3MVA are provided cooling through natural passage of environmental air.</p> <p>2. Air blast- In case of air blast cooling more than 3MVA transformer are considered where high-pressure air passed to the windings for the cooling purpose.</p>	<p>CBSE Study Material</p>	<p>Transformer</p>		<p>3</p>
<p>Q. 18</p>	<p>Universal Motors These motors are exactly same as D.C. series motors. They can be operated both on A.C. (Single Phase) and D.C supply. In these motors, the field and the armature are connected in series with each other. For changing the directions of rotation either armature or field connections are changed. The principle of this motor is the same as that of D.C series motor. The speed of universal motor is inversely proportional to the load i.e. at high load, its speed is low but at small load, its speed is high. The torque of this motor is directly proportional to the current taken by the motor. The motor is started on putting the load. The starting device used with this type of motor is auto-transformer with the help of which the voltage is raised on the motor gradually so that the motor is saved from high starting current.</p> <p>Applications These motors are used for household appliances such as table fan, vacuum cleaner, hair drier, sewing machine and small electric drill machine etc.</p>	<p>CBSE Study Material</p>	<p>DC/AC Motor</p>		<p>3</p>
<p>Q. 19</p>	<p>It is one of the most useful domestic appliances. In other words, it is called a Liquidizer, Mixer and Food grinder. It is used to grind the fruits, coffee seeds, nuts and to prepare delicious creamy, smooth milk shakes, lassi or other drinks etc. to make them tasty. It mostly consists of an a. c. motor of high speed (15000 to 17000 RPM) connected with a switch and supply leads fixed in the bottom bowl. The motor is fixed in such a way that its shaft is brought out vertically in the top bowl with which the blade is fixed to mix the liquid products or to grind the fruits etc. The two bowls are set in such a way that even a drop of water does not pass through the shaft and enter in the bottom bowl. If it happens, it means the mixer has become defective and motor is damaged very soon. The top bowl is covered with top cover. A handle is</p>	<p>CBSE Study Material</p>	<p>Elec. Appliances</p>		<p>3</p>

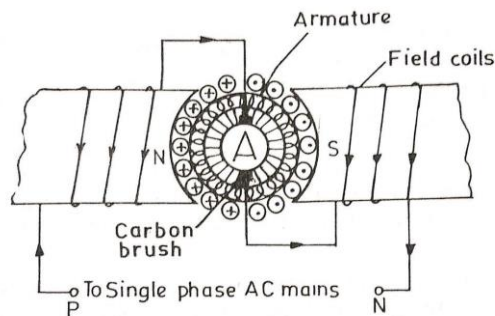

fixed on the side of the top bowl to use it. The lower part of bowl of mixer is made mostly with plastic, or ebonite. The upper bowl is made of thick transparent glass to see the mixed material easily. The upper bowl is set on the coupling fixed to the lower bowl and is removed easily.

The operation of mixer can be understood in this way. Different fruits or liquid products are put in top bowl and covered with top cover. The supply plug is connected with the supply and switched on. Then the switch of the motor is turned on and the motor works at high speed. The blade attached with the shafts moves fast and grinds the fruits and mixes the liquid products. The speed of the motor can be controlled with the switch knob. Before pouring out the mixed products, the supply is switched 'off' first. To grind the solid things, the special type blades with separate bowls are attached to the motor shaft, after removing the original bowl.

Answer any 3 out of the given 5 questions in 50– 80 words each (4 x 3 = 12 marks)

Q. 20

Working of Single-phase induction type Energy Meter

The basic working of Single-phase induction type Energy Meter is only focused on two mechanisms:

1. Mechanism of rotation of an aluminum disc which is made to rotate at a speed proportional to the power.
2. Mechanism of counting and displaying the amount of energy transferred.

1. Mechanism of rotation of an aluminum disc

Which is made to rotate at a speed proportional to the power.

The metallic disc is acted upon by two coils. One coil is connected Or arranged in such a way that it produces a magnetic flux in proportion to the voltage and the other produces a magnetic flux in proportion to the current. The field of the voltage coil

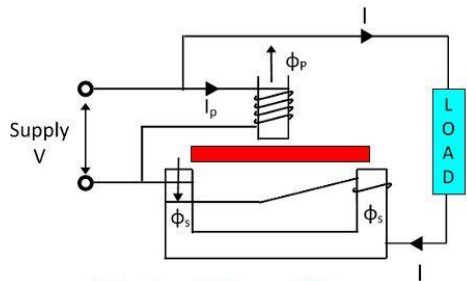

Working of Energy Meter

is delayed by 90 degrees using a lag coil. This produces eddy currents in the disc and the effect is such that a force is exerted on the disc in proportion to the product of the instantaneous current and voltage. A permanent magnet exerts an opposing force proportional to the speed of rotation of the disc – this acts as a brake which causes the disc to stop spinning when power stops being drawn rather than allowing it to spin faster and faster. This causes the disc to rotate at a speed proportional to the power being used.

2. Mechanism of displaying the amount of energy transferred

Based on number of rotations of aluminum disc.

The aluminum disc is supported by a spindle which has a worm gear which drives the register. The register is a series of dials which record the amount of energy used. The dials may be of the cyclometer type, an odometer-like display that is easy to read where for each dial a single digit is shown through a window in the face of the meter, or of the pointer

CBSE Study Material

Measuring Instruments

4

type where a pointer indicates each digit. It should be noted that with the dial pointer type, adjacent pointers generally rotate in opposite directions due to the gearing mechanism.

Q. 21 Star-Delta Motor Starter

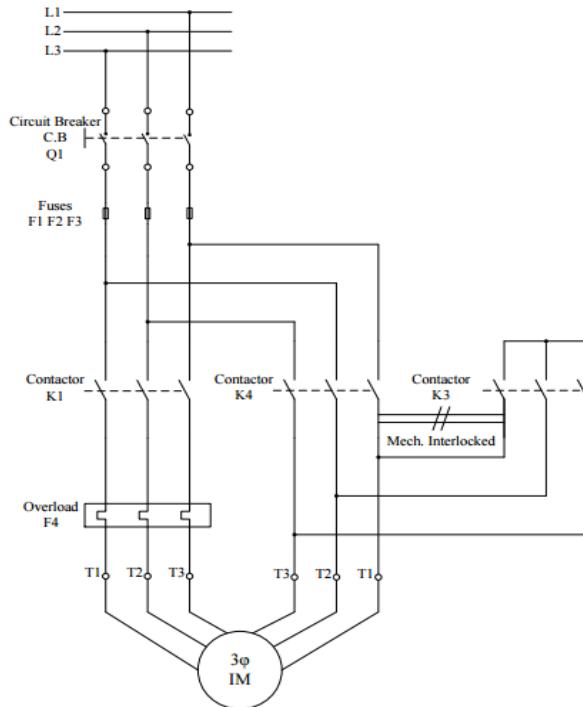

The Star Delta starting method is a motor starting mechanism that minimizes the large amount of starting current that motors draw in. The Star Delta, as the name suggests basically involves feeding the motor with $1/\sqrt{3}$ (58%) of the full load current until it attains speed then applying the full load current. It is required three contactors i.e., the Star Contactor (K3), the Delta Contactor (K4) and the Main Contactor (K1). However, for the motor to be started in Star Delta, its internal connection at the terminal box has to be wired in Delta-giving it capability of receiving the full-load current at any instant. When the power is fed into the circuit, K1 allows current to flow to the motor. Current flows into the motor and out to the K3 which is the star-connected starter. After a specified period defined by the clock delay (usually 5 sec) the K4 (Delta) Closes and K3 opens to allow the motor to receive the full load current and run at delta. Traditionally, in many regions there was a requirement that all motor connections be fitted with a reduced voltage starter for motors greater than 4KW (5HP). This was to curb the high inrush of starting currents associated with starting induction motors. The star and delta contactors are mechanically interlocked i.e., if one of them is closed the other cannot close. This is done to avoid dead short circuit in case both the contactors closing simultaneously. Electrical interlocking has also been provided, by using contactors control contacts. An advantage of this method could be low or reduced cost as compared to other methods.

CBSE Study Material

3-phase motor

4

Q. 22 Motor does not start
Faults
Rectification

CBSE Study Material

DC/AC Motor

4

	<ul style="list-style-type: none"> (i) Fuse is blown off replace fuse (ii) Defective starter replace starter (iii) Overload reduce load (iv) Short circuit remove by test it (v) Open circuit remove by test it <p>Speed of the motor is not correct</p> <ul style="list-style-type: none"> (i) Field coil wrong test field and correct connection (ii) Defective bearing change bearing (iii) End play is more should be not be more than 1/64 it (iv) More load on motor reduce load <p>Motor gets hot</p> <ul style="list-style-type: none"> (i) Pressure of carbon on the correct the pressure commutator is less or more (ii) Commutator short defective, remove if (iii) Carbon brush defective should be of good quality it (iv) Bearing jam after washing, fill the grease (v) Ball bearing defective up the dry bearing oil (vi) More load on the motor test it (vii) Wrong brush position replaces it <p>Sparking at commutator</p> <ul style="list-style-type: none"> (i) More load on machine reduce load (ii) Bad condition of brush holder replaces it (iii) Open short or ground on the armature test it (iv) Commutator segments are loose tight it (v) Position of brush is not correct the brushes after making correct fix <p style="text-align: right;">bidding</p>				
<p>Q. 23</p>	<p>Electric Geysers (Water Heater) To get the hot water, either continuously or intermittently, an electric water heater is more useful device. It can be easily installed anywhere with the electric power. Its water temperature can easily be regulated automatically by a thermostat. It works on the principle of thermal storage i.e.; the water is preheated by immersion water in a storage vessel and is kept for future use. To get the water in a storage vessel and is kept for future use. To get the hot water from time to time, the storing vessel is provided with thick insulation or it is properly legged to dissipate the heat. The heating element is fixed at the bottom horizontally or vertically. As the water heater is switched 'on' the cold water is heated up, becomes lighter and starts moving up while the cold water being heavier comes down. Thus, due to this circulation of water, we can get hot water from the outlet</p>	<p>CBSE Study Material</p>	<p>Elec. Appliances</p>		<p>4</p>

valve. If the element is fixed horizontally, the water above it, is heated very slowly but when the element is fixed vertically, the water surrounding this is heated up very soon. So, the vertical fitting of the element in the water heater is more referred.

Water heater may be classified in the following ways:

(a) Immersion Heater or Rod. It can be put in any vessel full of water and by switching on, the water is heated up. It is a portable and cheap and has been described before.

(b) Self-contained Heaters. These are of two types: (1) non-Pressure type (II) Pressure type

These consist of a storage vessel, heavily legged, electrically heated and provided with a thermostat system.

(a) Non-pressure Type Water Heater. This type of water heater is used at that place where the hot water is required only at one service point e.g., for wash-basins and sinks etc. Such water heaters have an open outlet i.e., not having any stop-cock. Its water is controlled from the inlet side. These contain two cylindrical vessels, one fitted inside the outer. The inner vessel consists of heating chamber made of tinned copper. Inside it, the heating element and thermostat are fixed vertically at the bottom. The outer vessel is made of lead-coated-steel and painted outside with enamel paint. The space between the two vessels is filled with heat resisting insulating material to reduce heat loss. The temperature of the water is controlled automatically with thermostat. The inlet and outlet pipes are chromium plated to avoid corrosion. The cold-water flows from the cold-water supply pipe (inlet pipe) and enters in the heating chamber and is controlled by a valve. The hot water flows out from the top of the heating chamber through the hot water pipe (outlet pipe). An anti-drip device is provided with the hot water pipe to cut off the quick hot water supply and to prevent the water to be drained off through the cold-water pipe valve when the supply of cold water fails. As the hot water pipe is an open outlet, when the cold-water inlet valve is opened, the cold-water rushes into the heating chamber, displaces and forces out an equal quantity of hot water through the hot water outlet pipe.

To save the water heater from the developed pressure inside the heating chamber, a vent plug is fitted at the top which allows extra pressure in atmosphere. The wattage of this water heater is about 750 to 2000 W etc.

(ii) Pressure Type Water Heater. In other words, it is called cistern type water heater as it works on atmospheric pressure. This type of water heater is used at that place where the hot water is required at more than one service points with one heater only. This heater gets its supply of cold water from the cistern (overhead tank) connected with the water mains and the water controlled with the help of a float valve. The copper pipes connected with the heating chamber are used to supply the hot water under pressure to different service points which are controlled with a tap. The element and thermostat are fixed at the removable plate fitted on the base of the water heater for their easy service and to remove them easily. The water is of 750 to 3000 W. These are of two types:

(i) Constant volume pressure type water heater. In this water heater, the hot water drained off is replaced equally with cold water having equal volume. So, it is called a constant pressure type water heater

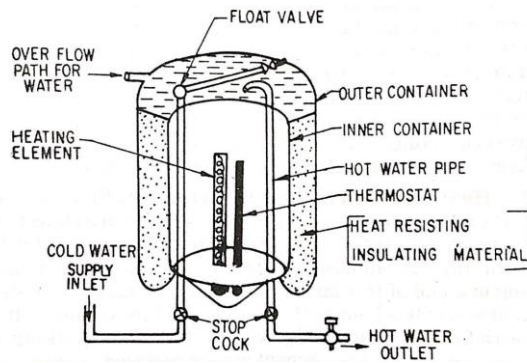

(ii) Non-constant volume pressure type water heater. In this water heater, the rate at which the hot water flows out is not the same at which the cold water enters into the heating chamber. So, it is known as non-constant or varying volume pressure type water heater.

Q. 24 Shaded Pole Motor. This motor consists of salient poles on the stator and squirrel cage rotor. The motor is made self-starting by making a one third cut in each of the laminated pole and the cut is short circuited with a copper ring which is known as shaded pole and so the motor is called shaded pole motor. The shaded poles are independent of the stator winding and have no connection with the winding. When the alternating current is sent through the winding surrounding the whole pole, the axis of the pole is shifted from the unshaded part to the shaded part which results the rotation of the rotor and the motor works as a self-starting motor.

These motors are made from 1/25 H.P. to 1/6 H.P. They are simple in construction and cheap but have very low starting torque, low efficiency and low overload capacity. Its efficiency varies from 5 to 35%. These motors are

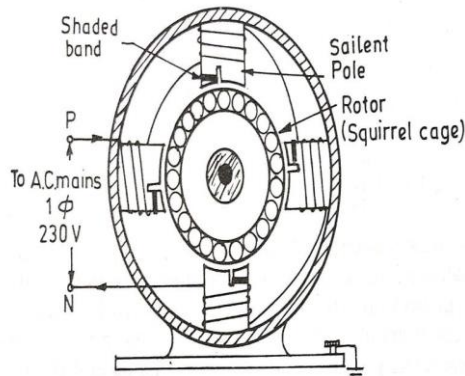

used for clocks, phonographs, hair driers, small fans, record players, ventilators, circulators, toys, instruments, projectors and advertising displays etc.

CBSE Study Material

Elec. Appliances

4